

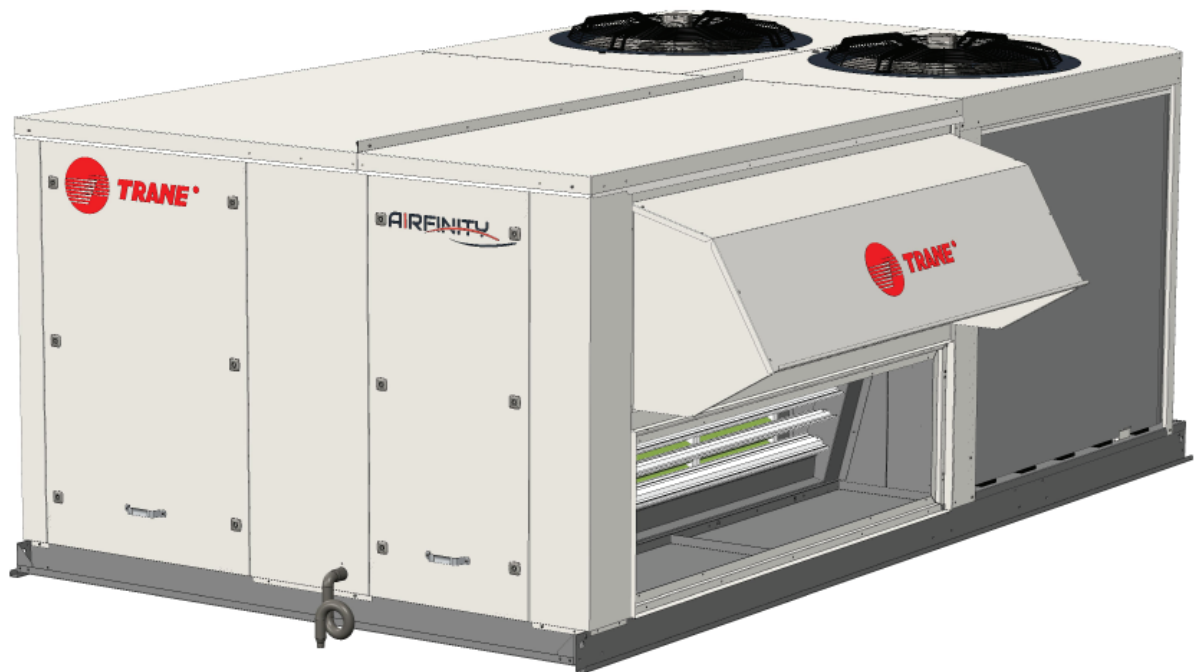

# Airfinity™ Packaged Rooftops

**Models**  
**IH – Reversible**  
**IC – Cooling-only**  
**40-135 kW**



**RT-PRC082A-GB**

# Table of Contents

<b>Introduction .....</b>	<b>4</b>
<b>Unit model number short description .....</b>	<b>5</b>
<b>Features and benefits.....</b>	<b>6</b>
<b>Options and accessories .....</b>	<b>9</b>
<b>Heat recovery solutions .....</b>	<b>13</b>
<b>Airfinity Solar.....</b>	<b>15</b>
<b>Product configuration .....</b>	<b>17</b>
<b>Operating map.....</b>	<b>21</b>
<b>General data.....</b>	<b>22</b>
<b>Dimensions and weights .....</b>	<b>24</b>
<b>Acoustic data .....</b>	<b>26</b>





# Introduction

The new **Trane Airfinity Rooftop** is the result of several years of customer research and Engineering development, in order to conceive a product which is both ready to face the tough environment of today, and embrace the challenging future which lies ahead.

## Value throughout the total lifecycle

Trane Airfinity™ Rooftops have been designed having in mind the complete lifecycle of the unit. Our high efficiency units will help you to reduce your operating costs and improve your carbon footprint. The easy plug-and-play installation and set-up will bring down your initial investments, while the smooth operation and proven reliability will help to minimize your downtime costs.

## Reduced installation costs

- Plug and play packaged solution
- Lightweight design
- Customizable return and supply air configuration
- Designed for quick replacement: compatible with a wide variety of roofcurbs
- Optimum compact packaging to reduce waste on-site

## Reduced operating costs

- High efficiency R410A scroll compressors in advanced refrigeration system
- Intelligent fresh air management and free cooling
- Reliable operation with the CH536 Trane controller
- Electronically Commutated (EC) plug fan with modulating airflow
- Electronic expansion valves
- Heat recovery module for maximum energy savings

## Reduced maintenance costs

- Double refrigeration circuit for enhanced reliability
- EC plug fan with zero maintenance
- Dynamic defrost cycles and anti-freeze protection
- Easy access to filtration and key components
- Remote unit management with alarm notifications

# Unit model number short description

E	I	H	085	S	A	E	A	A	X	D	1
1	2	3	4-6	7	8	9	10	11	12	13	14

**Digit 1 – Manufacturing location**

E = France

**Digit 2 – Range**

I = Airfinity™

**Digit 3 – Unit application**

H = Heat pump (reversible)

C = Cooling-only

**Digit 4,5,6 – Unit size**

Net heating capacity in kW

**Digit 7 – Efficiency**

S = Standard efficiency

**Digit 8 – Refrigerant**

A = R410A

**Digit 9 – Unit voltage**

E = 400 V / 3 Ph / 50 Hz

**Digit 10, 11 – Series**

**Digit 12 – Auxiliary heat**

G = Staged gas burner

M = Modulating gas burner

H = Hot water coil

E = Electric heater

X = Without

**Digit 13 – Gas type**

G = Propane gas

M = Natural gas

X = Without

**Digit 14 – Airflow configuration**

D = Downflow

H = Horizontal flow

See the Options & Accessories section for a more exhaustive list of options and accessories available.

## Features and benefits

AIRFINITY is a packaged plug and play solution, and an ideal all-in-one solution for retail applications. These units have been designed to be installed on the roof, but thanks to its versatility and flexibility, can also be installed on the ground.

Because Trane cares about delivering value, Airfinity units are equipped with many standard features that bring energy savings and improve comfort through tight temperature regulation and high indoor air quality.

### Casing

The indoor section is provided with double skin panels as standard, with 25 mm thick glass wool insulation. The unit casing is constructed of zinc coated, heavy-gauge, galvanized steel, painted with a polyester white RAL 9002 powder paint. All seams have been tightly sealed to prevent water leakages due to rain and snow. The modular cabinet construction allows easy access for maintenance on both sides of the unit.

Airfinity units are provided from the factory with horizontal or downflow configuration. To maximize flexibility on-site, it is possible to convert from downflow to horizontal flow on-site by ordering a simple conversion kit.

For different supply/return configurations, a multi-directional roofcurb is available (see Options).

### Advanced refrigeration circuits

AIRFINITY features high efficiency Scroll compressors units. The dual compressor models are outstanding for humidity control, light load cooling and heating conditions, and system back-up applications. The Trane Airfinity rooftop has among the best EER and COP in its class. All performances are Eurovent certified which provides the assurance of accurate performance and common comparison criteria

The design has been optimized to minimize pipe length and improve serviceability. The heat exchanger is manufactured using aluminized steel with copper tubes for maximum durability.

**Figure 1 – IH085 model**

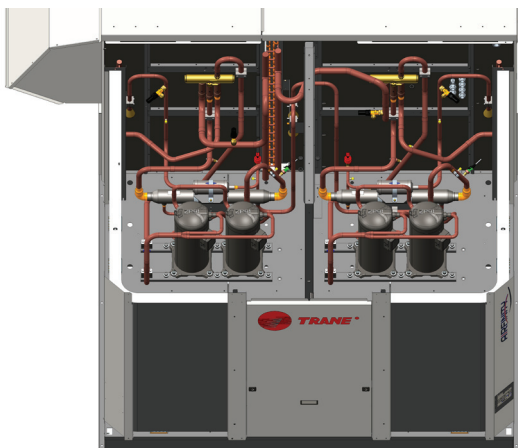

### Quality and reliability

All of Airfinity's designs were rigorously rain tested at the factory to ensure water integrity.

We perform a 100% coil leak test at the factory. The evaporator and condenser coils are leak and pressure tested at 5.0 MPa.

Every unit and its options receive a unit run test before leaving the production line to make sure it lives up to Trane requirements.

### Indoor Air Quality

The indoor air section is fully insulated with a double wall panel and glasswool insulation with 25 mm thickness and density according to norm DIN EN 1602. The insulation is completely self-maintaining. Panels in the indoor section are fire-resistant.

Each unit is equipped with two filter rails upstream of the indoor coil, with G4 filters with M1 fire classification provided as standard. Additional F5 (100mm), F7 (100 mm) and F9 (100mm) filters can be provided as optional. All filters are certified by Eurovent.

Airfinity rooftops are fitted with EC plug fans as standard to ensure that no rubber dust particles (typically associated to belt fans) will be carried into the air stream.

Our drain pans are made of galvanized steel and powder-painted to prevent corrosion. Moreover, they are sloped to prevent water stagnation that could lead to corrosion and microorganism life such as mold and fungi.

### Ventilation

For a typical retail application, your rooftop unit will run in part load more than 95% of the time. That's why Trane chose the EC plug fan, provided as a standard on all AIRFINITY units. Thanks to the variable speed technology, the rooftop is quieter, more efficient and more reliable compared to other solutions.

With the EC plug fan, you can also maximize comfort in your building and improve the indoor air quality:

- Prevent cold shower effect
- Prevent air stratification when using auxiliary heating
- Avoid rubber dust typically due to belt wearing
- Limited vibrations
- Reduced starting amps (suitable for textile ducts)
- Lower weight and lower installation cost

## Features and benefits

### CH536 Trane controller

The Trane CH536 controller software has been completely designed by Trane engineers, leverage many years of expertise in comfort cooling applications. It provides unit control for heating, cooling and ventilating utilizing input from sensors that measure outdoor and indoor temperature.

The CH536 controller improves quality and reliability through the use of time-tested controls and logic:

- Prevents the unit from short cycling, considerably improving compressor life.
- Ensures that the compressor will run for a specific amount of time which allows oil to return for better lubrication, enhancing the reliability of the compressor.
- Reduces the number of components required to operate the unit, thereby reducing possibilities for component failure.
- Features expanded diagnostic capabilities when utilized with Trane's Tracer™ Systems.
- Softens electrical "spikes" by staging on fans, compressors and heaters.
- Includes internal log memory to record unit operating trends (e.g. temperatures before alarm occurrence).

The Intelligent Fallback or Adaptive Control is a benefit to the building occupant. If a component goes astray, the unit will continue to operate at predetermined temperature set points.

**Figure 2 – Trane CH536 controller**

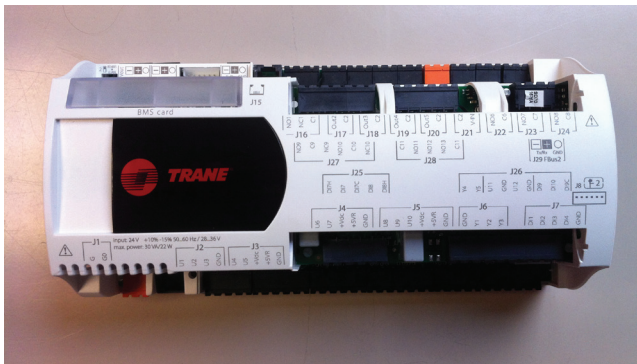

### Alternate defrost

Alternate defrost is provided as a standard feature on all Airfinity rooftop heat pump models. The intelligence is embedded into the unit controller and limits the number and the duration of the defrost cycles in cold conditions in order to improve reliability and maximize COP.

### Advanced heating management

In the case of heat pump and dual fuel units, heating priority is given by default to the most energy efficient mode (thermodynamic). Auxiliary heat modes (electric heater, hot water coil, gas burner) are activated when an additional need for heating is required.

Thanks to the CH536 controller, the user can customize the priority between different heating mode based on local atmospheric conditions and building needs.

### Electronic Expansion Valves

Airfinity™ utilizes electronic expansion valves (EEV) as standard on all models. Working together with the CH536 controller, the EEV allow to optimize the performances in both cooling and heating mode while providing reliable and accurate operation in all conditions, no matter what time of the year. Furthermore, unlike conventional expansion valves, EEV ensures smooth and precise control at low capacities, improving part load performances.

### Fresh air management and free cooling

Every Airfinity™ unit is provided with an economizer as standard. The economizer increases energy savings by enabling the free cooling mode every time outdoor conditions are favorable. This way, seasonal efficiency can be maximized by reducing the need for thermodynamic cooling in mid-season.

The economizer consists of:

- A motorized damper with separate fresh air and return air sections.
- A fresh air hood with a protection grille.
- Temperature sensors for free cooling operation (humidity sensors provided with enthalpy free cooling option).

## Features and benefits

Fresh air percentage can vary from 0 to 100% of nominal airflow. The mechanical opening of the damper is managed by the actuator which is adjusted by the Trane CH536 controller. When the unit is in free cooling mode, the damper will be automatically activated.

**Figure 3 – Economizer section in the Airfinity unit, shown with barometric relief damper**

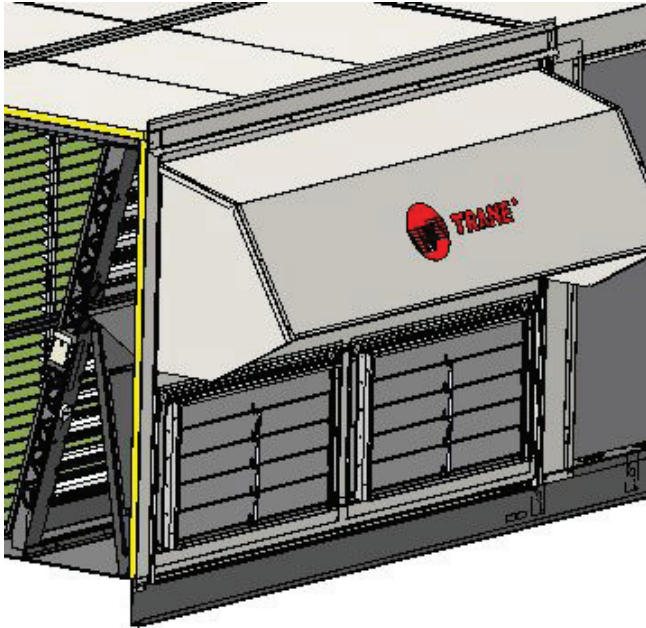

## Transport and handling

To facilitate handling of the unit and minimize waste on-site, Airfinity units are provided with lifting lugs located in the base frame of the unit and compact wooden blocks suitable for forklifting.

For handling instructions, please consult the Operation and Maintenance Manual.

## Serviceability

The Airfinity design uses up to 40% fewer parts than legacy units. Since it is simpler in design, it is easier to diagnose. Moreover, thanks to its consistent and modular design, no matter which Airfinity model you choose, the components are placed in the same location.

Rail systems have been implemented inside the cabinet in order to facilitate access to key components such as the supply fan, auxiliary heater and filters.

**Figure 4 – Easy access via rail system to key components on an Airfinity unit**

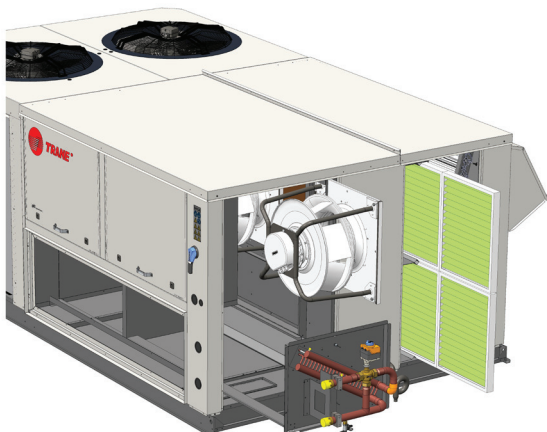



## Options and accessories

The Airfinity product line comes with a wide range of options and accessories to ensure all the flexibility and versatility you need.

### Auxiliary heat options

#### Hot water coil

The hot water coil can be fitted when additional heat is required and hot water is available from an external device (e.g. boiler). An additional factory-mounted coil is located after the indoor coil and offers fully modulating heating control by the use of a 3-way valve. The control is managed by measuring the zone temperature and adapting the supply air temperature.

To ensure proper operation, the pump circulating hot water should be permanently working to avoid water freezing in the coil. Otherwise, it is recommended to use ethylene glycol. Refer to Installation and Operation for more details.

For reversible units (IH models), priority is given by default to heat pump mode. Priority can be altered on-site.

**Figure 5 – Hot water coil located inside the unit**

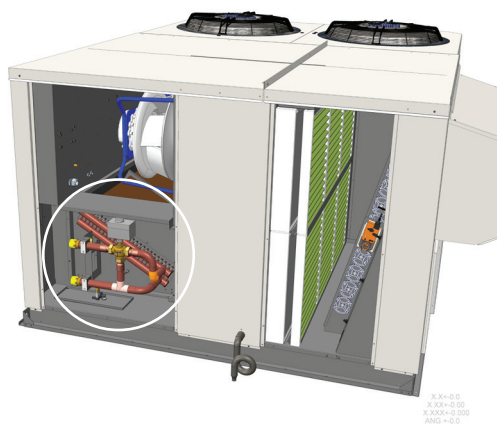

#### Electric heaters

Electric heaters are fitted in the heating section, under the supply fan discharge. The two-stage heaters are provided with two types of overheat thermostats:

- Automatic reset thermostats which stop the electric heater when the air temperature rises to 65°C. Automatic reset at 32°C.
- Manual reset thermostat which stops the unit when the air temperature rises to 128°C.

**Figure 6 – Electric heater fitted onto the unit**

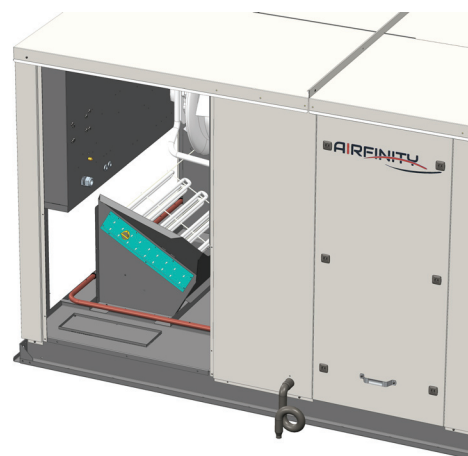

#### Gas burner

Both IH and IC models can be equipped with a gas burner.

The standard gas burner module offers 2 stages of control in order to improve zone comfort by avoiding large deviations in supply air temperature.

For applications that require a larger modulating range, modulating gas burners are available.

## Options and accessories

### Indoor Air Quality options

#### Filtration levels

Each unit is equipped with two filter rails upstream of the indoor coil, with G4 filters provided as standard. Additional F5 (100mm), F7 (100 mm) and F9 (100mm) filters can be provided as optional. All filters are certified by Eurovent.

All filters are provided with galvanized metallic frames.

**Figure 7 – Air filters**



**Table 1 – Filtration levels**

Filter class	Thickness	Efficiency (1)
G4	50 mm	90% gravimetric
G4+F7	50 mm + 100 mm	58% opacimetric
F5+F7	50 mm + 100 mm	58% opacimetric
G4+F9	50 mm + 100 mm	90% opacimetric

(1) Initial efficiency levels according to EN779:2012

#### Dehumidification function

When the room temperature reaches the desired set point but the humidity level is above the requirement, the Trane controller will automatically signal the unit to begin dehumidification of the supply air using an electric heater fitted into the unit.

This feature is particularly interesting for retail spaces which used closed cabinets, in order to prevent condensation on the windows.

### Control options

#### User interface (THS04)

The THS04 is a remote wall-mounted user interface intended for the end-user. It includes an incorporated temperature sensor which can be used as a room temperature sensor.

The intuitive graphical display provides information such as operating mode, ventilation status, temperature set points and indoor temperature. A user can set the temperature set point, switch the unit on or off and adjust the clock.

An admin user can access advanced settings of the THS04 via a password. The privileged access to adjust more parameters and view alarms. For more information, refer to the THS04 User Guide.

## Options and accessories

### Service interface (PGD)

The optional service interface can easily be plugged to the unit controller using a RJ25 phone cable. The interface is composed of six different buttons and a graphical display. This view of plug-and-play service and the controller allows building owners and maintenance personnel to read and modify all unit parameters such as unit settings, operating time and number of compressor starts, low and high pressure reading, and airflow rate of supply fan. The PGD also allows to read the history of the last 99 alarms.

The service terminal can be provided as loose or wall-mounted version and is available in multiple languages.

**Figure 8 – PGD Service Terminal**



### Building pressurization control

The external static pressure (ESP) of a rooftop unit is defined as the static pressure between inlet and outlet of the unit, including all options and accessories and excluding ductwork. This external static pressure will be used to push the air through the supply and the return ductwork installed on site. It can be computed summing the supply duct pressure drop with the return pressure drop.

It is recommended, for a basic unit, that the return ductwork pressure drop be lower than 150 Pa in order to accommodate operating modes which demand high fresh air rates, such as free cooling.

In the case that the return ductwork pressure drop is higher than 150 Pa, several exhaust options exist in order to control building pressurization.

### Barometric relief damper

Typically, the maximum overpressure recommended inside a building is 12 to 25 Pa. Excessive overpressure can lead to unwanted effects, such as tight doors, air whistling through windows and doors, etc.

The barometric relief damper uses gravity to relief pressure whenever fresh air is introduced into the building. It is recommended when the application demands fixed fresh air rates around 25%.

The return air pressure drop is above the building overpressure allowed by the customer (e.g. 25 Pa), the barometric relief dampers will open.

The barometric relief damper is installed under the fresh air section and provided as standard with the economizer for downflow configuration. One or two dampers are provided, dependent on the size of the unit.

**Figure 9 – Barometric relief damper**



### Exhaust fans

Multi-speed exhaust axial fans work together with the barometric relief dampers to provide air pressure relief when high fresh rates are being used. This option is recommended when there is a maximum of 150 Pa pressure drop in the return duct.

The exhaust fans are fitted in the fresh air section, before the economizer. They are only activated when the fresh air rate exceeds a preset value, and the overpressure can no longer be compensated by the barometric relief damper. Up to 50% of the nominal airflow can be exhausted, depending on the pressure drop in the return ductwork.

## Options and accessories

### Return roofcurb

The return roofcurb is recommended when there is a significant pressure drop in the return duct (up to 250 Pa). This options allows a tighter control of the return airflow and balances it with the supply airflow, especially when the supply fan is not enough to overcome both supply and return static pressure (ESP).

The return roofcurb is installed below the unit and has an EC plug fan integrated into the module. One or two plugs fans are included, depending on the unit size. The module is fully powered by the rooftop itself. The roofcurb is also equipped with an additional damper for the exhaust air.

This roofcurb can be used in either horizontal or downflow applications.

**Figure 10 – Airfinity unit with return roofcurb**

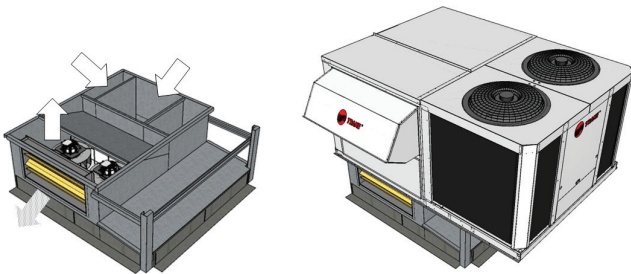

## Roofcurbs

### Adjustable roofcurb

A roofcurb serves as a connection between a flat or sloped roof and the rooftop unit. In addition to supporting the rooftop, it ensures water tightness and allows easy connection of the ductwork. Trane can provide high quality roofcurbs with up to 6% of inclination, adjustable on-site.

### Multi-directional roofcurb

This option is a required when an installation demands horizontal return and horizontal supply on the same side. It is also necessary when the customer requires a heat recovery module with horizontal flow configuration.

**Figure 11 – Multi-directional roofcurb**

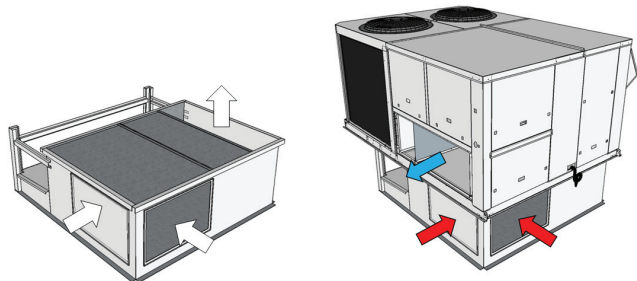

**Table 2 – Building pressurization options comparison**

	Barometric relief damper	Exhaust fans	Return roofcurb
<b>Building air tightness</b>	Medium	Medium	High
<b>Pressure drop in the return ductwork</b>	Below 50 Pa	Up to 150 Pa	Up to 250 Pa
<b>Building pressure control</b>	Low	Low	Medium
<b>Fresh air rate</b>	Low to medium	High	High
<b>Volume of exhaust air</b>	Low	Medium	Medium
<b>Typical applications</b>	Warehouses, large retail spaces	Small retail, gas stations	Cinemas, new air-tight buildings

# Heat recovery solutions

To enhance energy savings and reduce operating costs, Airfinity rooftops can be equipped with a packaged and easy-to-install heat recovery system. All heat recovery systems for rooftops provided by Trane are designed to maximize efficiency with little to no impact on footprint and installation time.

Heat recovery systems are ideal for climates in which there is a significant difference between outdoor and indoor air temperature (e.g. winter).

Trane provides two heat recovery solutions to address a wide variety of needs: **energy recovery module** and **thermodynamic heat recovery**.

## Energy Recovery Module (ERM)

The Energy Recovery Module is a packaged system that transfers the energy contained in the exhaust air to fresh air. It is an add-on module that includes a heat exchanger (rotary wheel), exhaust fan, G4 filter and dampers. The module is fully powered by the rooftops itself and managed via the Trane CH536 unit controller.

**Figure 12 – Trane Airfinity unit fitted with an Energy Recovery Module**



**Figure 13 – Trane Airfinity Energy Recovery Module**

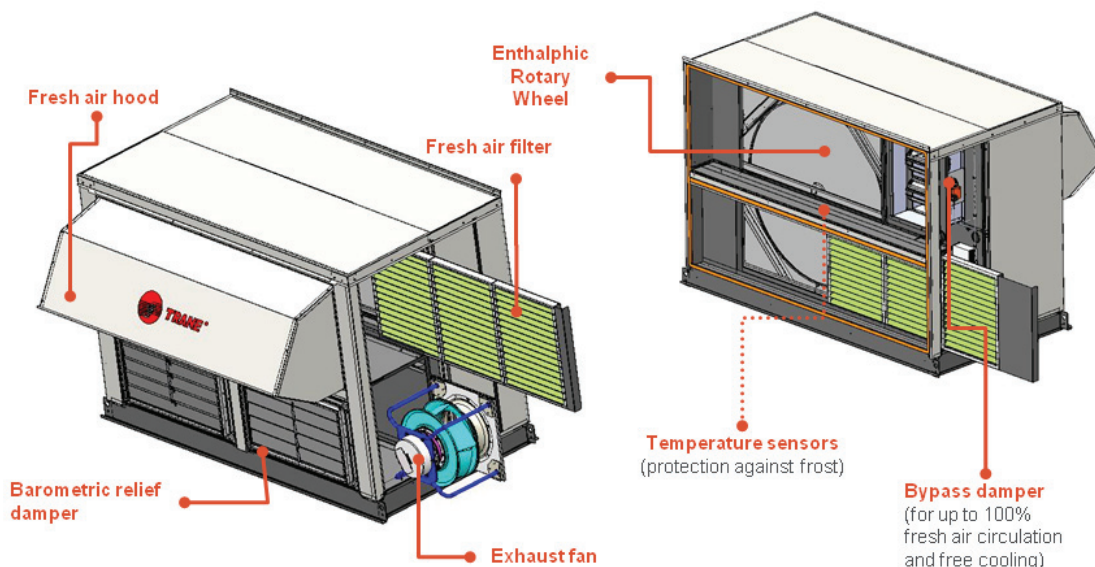

Thanks to the enthalpy rotary wheel, both sensible and latent heat is transferred from the exhaust air stream to the outdoor air stream, which makes this system more energy efficient compared to conventional plate heat exchangers. The module has been fully designed by Trane and optimized to minimize the overall pressure drop in the system. The rotary wheel is certified by Eurovent.

Airfinity rooftops fitted with the ERM can still benefit from free cooling mode, and high fresh air rates up to 100%.

The heat recovery system is recommended for applications with 20% to 40% of fresh air intake. When fresh air requirements exceed the airflow which can be managed by the wheel, the bypass damper will automatically open to compensate the excess air intake.

Every ERM is equipped with the necessary sensors and a micro-inverter to reduce the rotation speed of the wheel when the outdoor temperatures is below -2°C, in order to protect the module against freezing.

For more information regarding the installation and operation of the ERM, please consult the Installation & Operation Manual.

## Heat recovery solutions

### Thermodynamic Energy Recovery Circuit (ERC)

The Thermodynamic Energy Recovery integrated system is characterized by a dedicated high efficiency refrigeration circuit which uses the exhaust air to pre-heat or pre-cool the fresh air introduced into the building. By recovering the heat in the exhaust air, the overall capacity of the machine can be increased by up to 25% in typical working conditions without significantly impacting power consumption. Therefore, the overall efficiency of the rooftop unit is increased.

To maximize the efficiency of the unit, especially in part load conditions, priority is always given to the energy recovery circuit over the main unit refrigeration circuit when meeting capacity requirements.

Thanks to the additional refrigeration circuit and tighter control of the exhaust air, Trane's ERC system guarantees higher performances compared to alternative systems which utilize the outdoor coil.

**Table 3 – Energy Recovery Comparison**

	<b>ERC</b>	<b>ERM</b>
<b>Name</b>	<b>Energy Recovery Circuit</b>	<b>Energy Recovery Module</b>
<b>Technology</b>	Thermodynamic circuit	Enthalpy Rotary Wheel
<b>Type of heat recovery</b>	Active recovery	Static recovery
<b>Installation type</b>	Integrated inside the main unit	Add-on module
<b>Footprint impact</b>	None	Minimum
<b>Recommended fresh air rate*</b>	Up to 60%	30%
<b>Maximum fresh air rate</b>	100%	100%
<b>Maximum pressure drop</b>	50 Pa	150 Pa
<b>Installation cost</b>	Low	Low to medium
<b>Return on investment</b>	Low to medium	High

# Airfinity Solar

Air-conditioning and ventilation can represent up to 80% of your commercial building's energy consumption. Ironically, these systems consume valuable peak power at the same time that solar energy is most available.

By installing solar panels to power your HVAC equipment, you can reduce your carbon emissions and peak time electricity consumption. At the same time you can put unexploited rooftop space to good use while protecting your operation from future electricity price fluctuations.

Trane has committed to developing a solution that can reduce your operating costs while using sustainable and clean energy: **Airfinity™ Solar**. Trane Airfinity™ Rooftops have been specially designed to be solar-ready. That means you can now use clean solar energy to partially or totally power your air-conditioning system while continuing to benefit from the quick and easy installation of a direct expansion system. Our integrated solar rooftop solution offers you an innovative and reliable way of reducing operating costs without compromising comfort, while drastically reducing the carbon footprint of your building.

Airfinity Solar consists of a pre-packaged solution comprising all the elements required to set up your own self-consumption off-grid solution.

## Airfinity Solar

The natural choice.

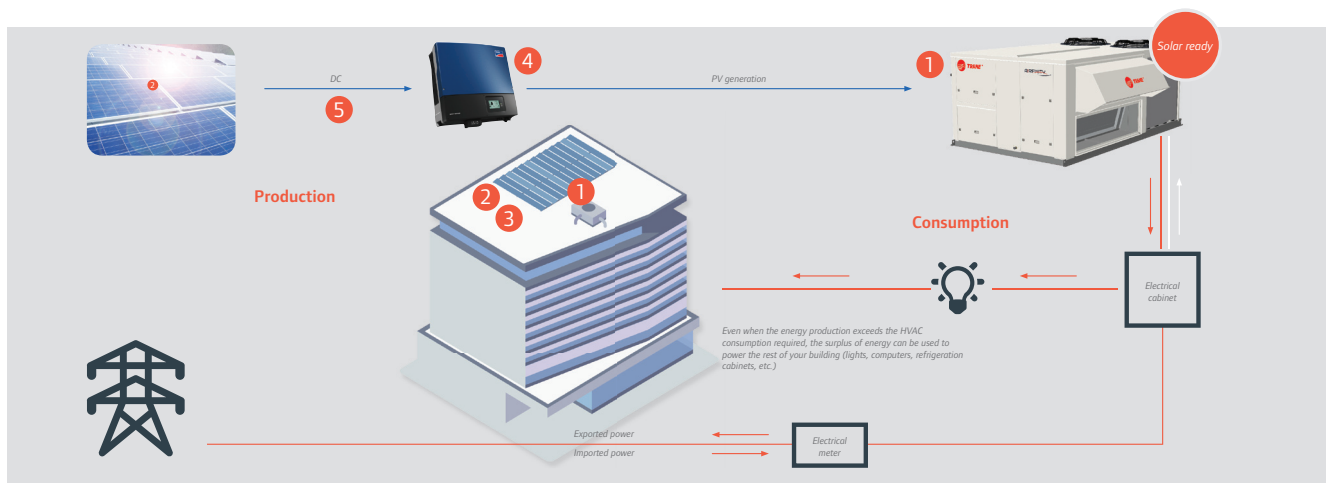

- 1) Airfinity™ rooftop units.
- 2) Silicon photovoltaic panels: The most widely-used technology to convert solar energy into DC electrical power.
- 3) Mounting structure: Used to support the PV panels without puncturing the building's roof. The membranes are durable but lightweight and serve as a wind deflector.
- 4) High efficiency inverter: Converts DC power supply provided by the PV panels into AC power needed to operate the rooftop HVAC unit and to feed into the utility grid.
- 5) Cables and connectors: Double-insulated and UV resistant cables suitable for rooftop applications with water resistant IP65 crimped connectors.

## Airfinity Solar

There are two types of pre-packaged kits available:

- **PV-S:** Solar PV kits with south mounting configuration
- **PV-EW:** Solar PV kits with east-west mounting configuration

**Table 4 – Airfinity solar kit data**

<b>Airfinity Solar PV-S kits</b>		<b>PV05S</b>	<b>PV08S</b>	<b>PV12S</b>	<b>PV15S</b>	<b>PV20S</b>	<b>PV25S</b>	<b>PV35S</b>	<b>PV40S</b>	<b>PV50S</b>
Nominal PV power	(kWp)	6	9	13	16	21	26	37	42	52
Number of panels		22	34	50	62	82	100	144	160	200
Power DC output per panel	(Wc)	260	260	260	260	260	260	260	260	260
Roof space required (without shadows and obstructions)	(m <sup>2</sup> )	58	90	132	164	216	264	380	422	528
Number of inverters		1	1	1	1	1	1	2	2	2
<b>Expected yearly production based on local irradiance factor (1)</b>										
900 kWh/m <sup>2</sup> (Benelux)	(kWh)	4800	7400	10900	13500	17850	21750	31350	34800	43500
1400 kWh/m <sup>2</sup> (Lyon)	(kWh)	7450	11500	16950	21000	27750	33850	48750	54150	67700
1600 kWh/m <sup>2</sup> (Rome)	(kWh)	8500	13150	19350	24000	31700	38700	55700	61900	77400
1750 kWh/m <sup>2</sup> (Madrid)	(kWh)	9300	14400	21150	26250	34700	42300	60950	67700	84650
<b>Airfinity Solar PV-EW kits</b>		<b>PV05EW</b>	<b>PV08EW</b>	<b>PV12EW</b>	<b>PV16EW</b>	<b>PV20EW</b>	<b>PV24EW</b>	<b>PV30EW</b>	<b>PV40EW</b>	<b>PV50EW</b>
Nominal PV power	(kWp)	6	9	13	17	21	26	31	42	52
Number of panels		22	34	50	64	82	100	120	160	200
Power DC output per panel	(Wc)	260	260	260	260	260	260	260	260	260
Roof space required (without shadows and obstructions)	(m <sup>2</sup> )	44	67	99	127	162	198	238	317	396
Inverter model (DC/AC)		1	1	2	2	2	2	2	2	2
<b>Estimated yearly production based on local irradiance factor (1)</b>										
900 kWh/m <sup>2</sup> (Benelux)	(kWh)	4650	7150	10550	13500	17250	21050	25250	33700	42100
1400 kWh/m <sup>2</sup> (Lyon)	(kWh)	7200	11150	16400	20950	26850	32750	39300	52400	65500
1600 kWh/m <sup>2</sup> (Rome)	(kWh)	8250	12750	18700	23950	30700	37450	44950	59900	74900
1750 kWh/m <sup>2</sup> (Madrid)	(kWh)	9000	13900	20500	26200	33600	40950	49150	65500	81900

(1) Subject to local weather conditions and dependent on good design and maintenance practice.



# Product configuration

## Basic airflow configurations

Downflow (Digit 14=D):

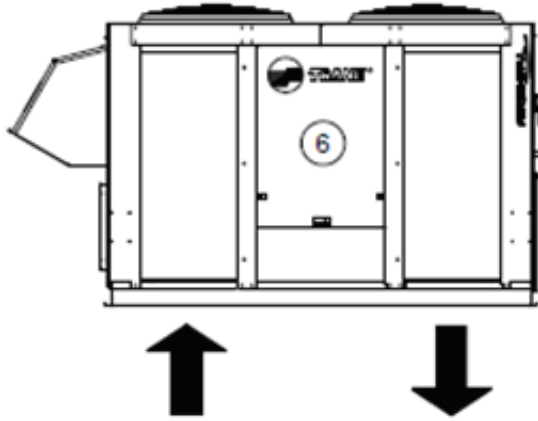

Horizontal flow (Digit 14=H):

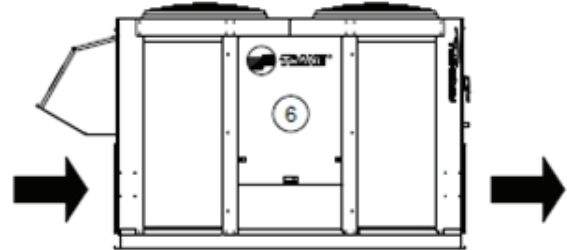

Customizable return / supply flow:

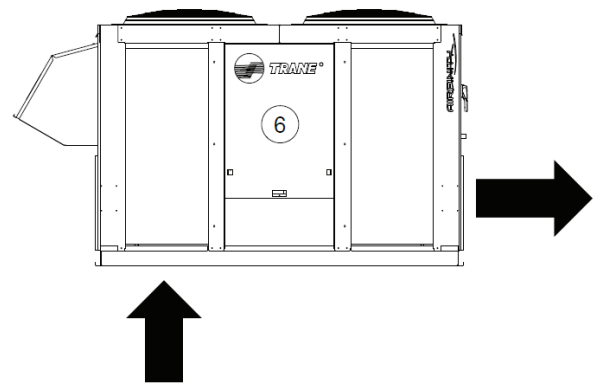
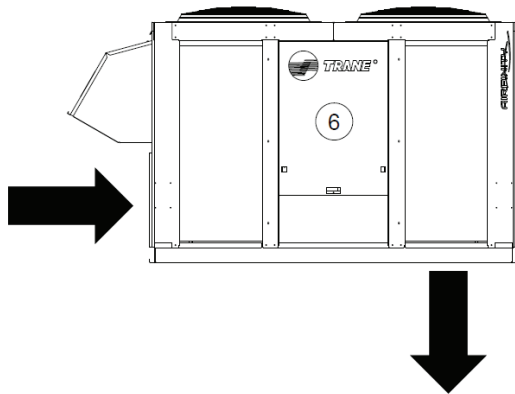

## Key digit descriptions

### Digit 14 - Airflow configuration

D = Down Flow  
H = Horizontal Flow

### Digit 18 - Heat Recovery Module

X = Without  
R = Configured for Rotary Wheel  
T = Thermodynamic circuit

### Digit 31 - Building Pressurization Control

X = Without  
1 = Barometric relief damper  
2 = Exhaust Fan (ESP=70 pa)  
3 = Exhaust Fan - High speed (ESP=150 Pa)  
4 = Configured for Return roofcurb (ESP=250 Pa)

### Digit 32 - Multidirectional roofcurb

X = Without  
1 = Configured for multidirectional roofcurb

## Product configuration

Table 5 – Product matrix

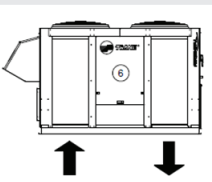
Unit configuration	Custom return/supply configuration	Building pressurization control	Energy recovery	Compatibility	
Digit 14	Digit 32	Digit 31	Digit 18		
 <p><b>Horizontal flow</b></p>	Without multi-directional roofcurb	Barometric relief	ERM (1)	(1)	
			ERC (1)	(1)	
			Without		x
		Exhaust fan	ERM (2)	(2)	
			ERC (2)	(2)	
			Without		x
		Return roofcurb	ERM	x	
			ERC	x	
			Without	x	
	Without	ERM	x		
		ERC	x		
		Without	√		
	With multi-directional roofcurb	Barometric relief	ERM	x	
			ERC	x	
			Without	√	
		Exhaust fan	ERM	x	
			ERC	x	
			Without	√	
Return roofcurb		ERM	√		
		ERC	√		
		Without	√		
Without	ERM	√			
	ERC	√			
	Without	√			
 <p><b>Down flow</b></p>	Without multi-directional roofcurb	Barometric relief	ERM (1)	(1)	
			ERC (1)	(1)	
			Without		√
		Exhaust fan	ERM (2)	(2)	
			ERC (2)	(2)	
			Without		√
		Return roofcurb	ERM	√	
			ERC	√	
			Without	√	
	Without	ERM	√		
		ERC	√		
		Without	√		
	With multi-directional roofcurb	Barometric relief	ERM (1)	(1)	
			ERC (1)	(1)	
			Without		√
		Exhaust fan	ERM	x	
			ERC	x	
			Without	√	
Return roofcurb		ERM	x		
		ERC	x		
		Without	x		
Without	ERM	√			
	ERC	√			
	Without	√			

The above matrix is intended merely for guidance. For a proper selection, please contact your local Trane sales office.

(1) Barometric relief already included in ERM / ERC

(2) Exhaust fan already included in ERM / ERC

## Product configuration

### Options and Accessories

Legend: (S) Standard feature (O) Factory-fitted option (A) Field-mounted accessory

	Name	Application / benefit	Type	IH	IC
VENTILATION & IAQ	<b>G4 filters</b>	Filter the air – 50mm	S	✓	✓
	<b>G4+F7 filters</b>	Filter the air – 50mm + 100mm	O	✓	✓
	<b>G4+F9 filters</b>	Filter the air – 50mm + 100mm	O	✓	✓
	<b>F5+F7 filters</b>	Filter the air – 50mm + 100mm	O	✓	✓
	<b>Clogged filter detector</b>	To facilitate maintenance of the filters by sending an alarm whenever the pressure drop of the filter reaches or exceeds an user-defined value	O	✓	✓
	<b>EC plug fan</b>	Modulating airflow on supply fan to deliver optimum comfort with higher energy savings. Includes progressive start-up for textile duct applications	S	✓	✓
	<b>Dehumidification</b>	Suitable for retail spaces which use closed refrigeration cabinets. Unit is fitted with electric heater which manages dehumidification of the air	O	✓	✓
FRESH AIR MANAGEMENT	<b>Fresh air damper and hood</b>	A motorized fresh air damper introduces a permanent amount of fresh air into the unit, up to 100% of the nominal airflow. The damper position is adjusted by an actuator managed by the Trane controller.	S	✓	✓
	<b>Economizer (free cooling)</b>	The economizer comprises the fresh air hood, damper and sensors to enable free cooling when outdoor conditions are favorable. Dry bulb control (temperature-based) provided as standard.	S	✓	✓
	<b>Enthalpy control</b>	Economizer is equipped with an additional humidity sensor in order to measure indoor and outdoor enthalpy (energy content), for more accurate control and higher energy savings	O	✓	✓
	<b>Heat Recovery Module</b>	Allows to recovery heat from the exhaust air and transfer it to the fresh air, thus reducing the need for mechanical work. Module is installed on the fresh air side of the unit with no impact on the footprint	A	✓	✓
	<b>CO<sub>2</sub> sensor</b>	Sensor installed in the room or ductwork measures the concentration of carbon dioxide (e.g. level of occupancy) in order to increase or decrease the fresh air amount in the buildings	O	✓	✓
PRESSURIZATION	<b>Barometric relief damper</b>	Reliefs pressure when fresh air is being introduced into the building. Adequate for buildings with good air tightness. Available as standard on downflow units only.	S	✓	✓
	<b>Exhaust fans</b>	Minimizes overpressure in the building caused by introduction of fresh air, used in combination with barometric relief damper (included). Pressure drop in the return ductwork up to 150 Pa	O	✓	✓
	<b>Return roof curb</b>	For applications with high fresh air rates and where system balancing is critical. Roof curb with additional damper and EC plug fan extracts up to 300 Pa at nominal airflow rate.	A	✓	✓
SAFETY	<b>Smoke detector</b>	Trips off in case of presence of smoke in the supply side of the unit. Automatically closes the return air and stops the unit.	A	✓	✓
	<b>Fire thermostat</b>	Stops the unit when temperature of the air stream rises abnormally	A	✓	✓
	<b>Epoxy fin coating</b>	Provides additional coil corrosion resistance to protect indoor and outdoor aluminum fins	O	✓	✓
	<b>Network protection relay</b>	Detects phase loss, reversal and imbalance from main power supply/ In case of fault, unit stops. Phase reversal protection provided as standard	O	✓	✓
	<b>Compressor soft starter</b>	Limits the starting current of the compressor for a smooth re-start (e.g. after a power failure)	O	✓	✓
AUX.	<b>Hot water coil</b>	Provides auxiliary heating using hot water (requires hot water external device such as heat pump or boiler, etc.)	O	✓	✓
	<b>Electric heater</b>	Provides auxiliary heating using electric heater fitted to the unit	O	✓	✓
	<b>Gas burner</b>	Provides auxiliary heating using staged or modulating gas burner module fitted to the unit	O	✓	✓

## Product configuration

	Name	Application / benefit	Type	IH	IC
<b>CONTROLS</b>	<b>Airflow measurement</b>	Allows to measure airflow based on air differential pressure sensor. PGD Display included.	A	✓	✓
	<b>Remote service terminal (PGD)</b>	Service terminal intended for use by building owners and maintenance personnel. Allows to access and adjust advanced unit parameters.	A	✓	✓
	<b>THS04 Room User interface</b>	Simple user interface to access and adjust basic unit parameters. Includes room temperature thermostat. Intended for end-users.	A	✓	✓
	<b>ModBus interface</b>	To communicate on a ModBus network at the unit level.	<b>S</b>	✓	✓
	<b>BacNet interface</b>	To communicate on a BACnet® MS/TP network at the unit level. Suitable for integration with Building Management Systems.	O	✓	✓
	<b>LonTalk interface</b>	To communicate on a BACnet® MS/TP network at the unit level. Suitable for integration with Building Management Systems.	O	✓	✓
	<b>Customer I/O option module</b>	Module required for user-defined external input/output signals (i.e. conventional thermostat). PGD service terminal recommended.	O	✓	✓
<b>ENERGY RECOVERY</b>	<b>Energy recovery module (ERM)</b>	Recover energy contained in the exhaust air using an enthalpy rotary wheel. Mixed air streams increase efficiency of the machine.	O	✓	✓
	<b>Energy recovery circuit (ERC)</b>	Recover energy contained in the exhaust air using an additional refrigeration circuit contained in the main unit.	O	✓	✓
	<b>Low ambient</b>	Recommended when units are expected to work below +10°C outdoor air in cooling mode. EC axial fans are fitted to the condensing section to reduce the airflow when required.	O	✓	✓

# Operating map

## Cooling mode

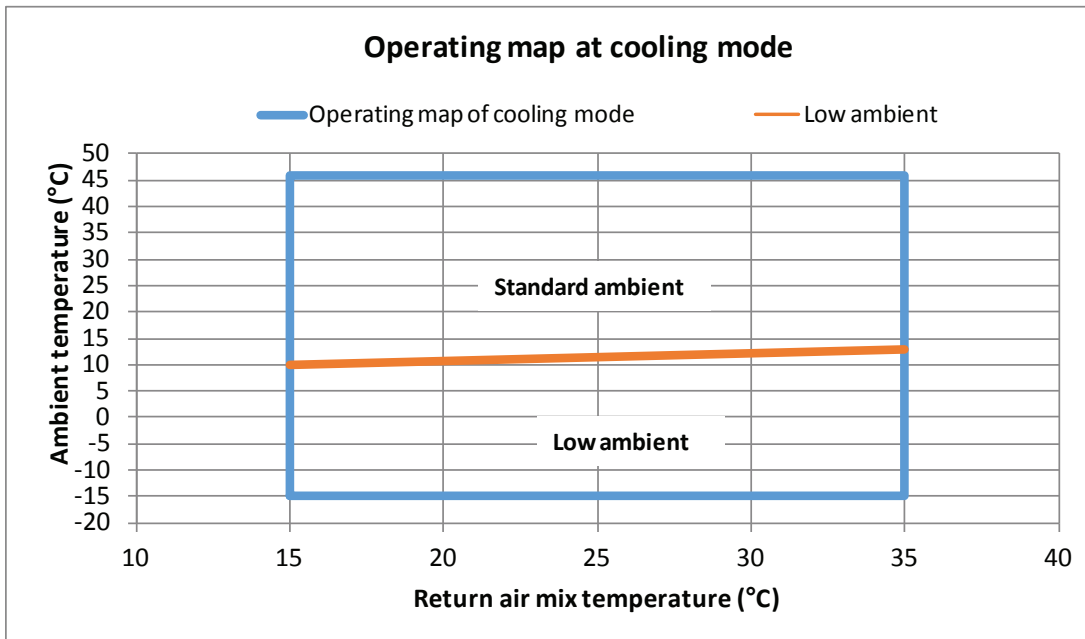

Maximum Outdoor Temperature (@ Eurovent) = 46°C  
 Minimum Outdoor Temperature = -5°C  
 Maximum Indoor Coil Entering Temperature = 35°C  
 Minimum indoor Coil Entering Temperature = 18°C

## Heating mode

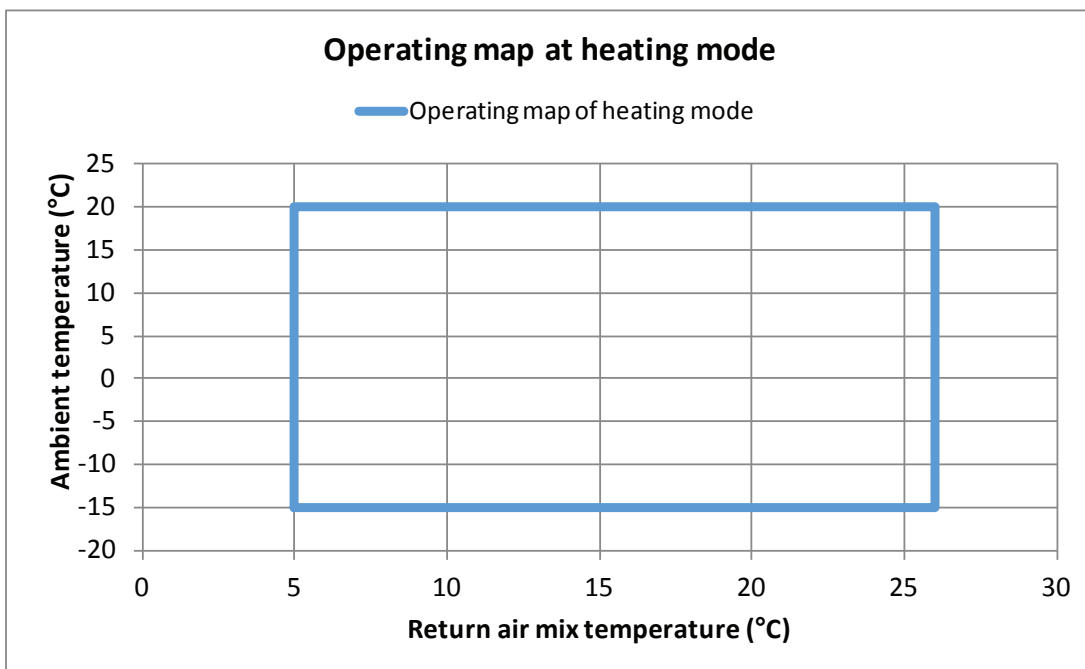

Maximum Outdoor Temperature (@ Eurovent) = 20°C  
 Minimum Outdoor Temperature = -15°C  
 Maximum Indoor Coil Entering Temperature = 27°C  
 Minimum indoor Coil Entering Temperature = 5°C

**Note:** For units expected to operate in cooling mode with an outdoor air temperature below +10°C, the Low Ambient option is recommended.

# General data

**Table 6 – Single compressor per circuit models**

Models IH		039	049	059	064	074	084
Number of circuits / compressors		2 / 2	2 / 2	2 / 2	2 / 2	2 / 2	2 / 2
Nominal airflow	(m <sup>3</sup> /h)	8200	10000	11100	12400	15500	16700
Available static pressure at nominal flow rate	(Pa)	250	250	250	250	250	250
Available static pressure at nominal flow rate (oversized drive)	(Pa)	500	500	500	500	500	500
<b>Performance data (cooling mode) (1)</b>							
Net cooling capacity (1)	(kW)	43	52	58	65	80	87
Total power input	(kW)	13	17	20	25	27	31
Net EER	kW / kW	3.4	3.1	2.8	2.6	3.0	2.8
Eurovent Energy class		A	A	B	C	A	B
Seasonal space efficiency	%	166	152	138	128	145	135
Operating outdoor air temperature range (min./max.)	(°C)	10 / 46	10 / 46	10 / 46	10 / 46	10 / 46	10 / 46
Operating outdoor air temperature range (min./max.) - Low ambient	(°C)	-15 / 46	-15 / 46	-15 / 46	-15 / 46	-15 / 46	-15 / 46
<b>Performance data (heating mode)</b>							
Net heating capacity	(kW)	38	47	54	63	71	78
Total power input	(kW)	11	14	17	20	21	24
Net COP	kW / kW	3.4	3.3	3.1	3.1	3.4	3.3
Eurovent Energy class		A	B	C	C	A	B
Seasonal space efficiency	%	111	109	104	106	103	102
Operating outdoor air temperature range (min./max.)	(°C)	-15 / 20	-15 / 20	-15 / 20	-15 / 20	-15 / 20	-15 / 20
<b>General data</b>							
A-weighted Outdoor sound power level (2)	(dB(A))	85	85	85	85	86	86
A-weighted sound power level in duct (2)	(dB(A))	83	88	93	97	84	87
Auxiliary electric heating capacity - Stage 1 / 2	(kW)	12,5 / 12,5	12,5 / 12,5	12,5 / 25	12,5 / 25	12,5 / 25	12,5 / 25
Auxiliary gas burner heating capacity	(kW)	Available Spring 2017					
<b>Weights and dimensions (Operating)</b>							
Length	(mm)	3010	3010	3010	3010	3890	3890
Width	(mm)	2250	2250	2250	2250	2250	2250
Height	(mm)	1565	1565	1565	1565	1585	1585
Weight (downflow - without options)	(kg)	988	1005	1016	1016	1333	1347
<b>Electrical Data</b>							
Power supply		400 V / 3 Ph / 50 Hz					
Maximum running amps	(A)	41	46	56	65	68	84
Start-up amps	(A)	127	157	175	186	201	209
Start-up amps (with soft starter)	(A)	92	113	126	135	145	155
<b>Additional amps per option</b>							
Electric Heater	(A)	36	36	54	54	54	54
Exhaust Fan (70pa)	(A)	1	1	1	1	1	1
Exhaust Fan (150pa)	(A)	1	1	1	1	2	2
Return Roofcurb	(A)	5	5	5	9	11	11
Energy Recovery Module (ERM)	(A)	8	8	8	8	8	8
<b>Supply fan data</b>							
Fan type		Plug Fan	Plug Fan	Plug Fan	Plug Fan	Plug Fan	Plug Fan
Drive Type		EC Motors	EC Motors	EC Motors	EC Motors	EC Motors	EC Motors
Minimum Airflow	(m <sup>3</sup> /h)	6560	8000	8880	10300	12400	13360
Nominal Airflow	(m <sup>3</sup> /h)	8200	10000	11100	12400	15500	16700
Maximal Airflow	(m <sup>3</sup> /h)	10660	13000	14430	16120	20150	21710
Number of fans	#	1	1	1	1	2	2
Motor Max Amps per fan	(A)	5	5	9	9	5	5
Motor Power - Standard drive (1)	(kW)	0.9	1.4	2.0	2.6	2.1	2.6
Motor Power - Oversized drive (1)	(kW)	0.9	1.4	2.0	2.6	2.2	2.7
Motor RPM at nominal flow rate - Standard drive (1)	RPM	1247	1502	1676	1851	1321	1426
Motor RPM at nominal flow rate - Oversized drive (1)	RPM	1247	1502	1676	1851	1321	1423
Available Static Pressure at nominal flow rate - Standard drive	(Pa)	250	250	250	250	250	250
Available Static Pressure at nominal flow rate - Oversized drive	(Pa)	500	500	500	500	500	500
<b>Condenser fan data</b>							
Fan type		Axial	Axial	Axial	Axial	Axial	Axial
Drive type - Standard ambient		AC motor	AC motor	AC motor	AC motor	AC motor	AC motor
Drive type - Low ambient		EC motor	EC motor	EC motor	EC motor	EC motor	EC motor
Number of fans per circuit	#	1	1	1	1	1	1
Motor Power	(kW)	0.5	0.5	0.5	0.5	0.7	0.7
Motor Max Amps per fan	(A)	1	1	1	1	2	2
Motor RPM	RPM	910	910	910	910	686	686

(1) At standard Eurovent rating conditions.

(2) Sound power levels were measured following the ISO 9614 as recommended by Eurovent requirement. All data are given according to standard EN 12102:2013.

## General data

**Table 7 – Dual compressor per circuit models**

Models IH		040	050	060	065	075	085	100	110	130
Number of circuits / compressors		2 / 4	2 / 4	2 / 4	2 / 4	2 / 4	2 / 4	2 / 4	2 / 4	2 / 4
Nominal airflow	(m <sup>3</sup> /h)	8700	10600	12100	13700	15700	16700	19800	21600	25500
Available static pressure at nominal flow rate	(Pa)	250	250	250	250	250	250	250	250	250
Available static pressure at nominal flow rate (oversized drive)	(Pa)	500	500	500	500	500	500	500	500	500
<b>Performance data (cooling mode) (1)</b>										
Net cooling capacity (1)	(kW)	45	56	64	72	82	88	104	113	133
Total power input	(kW)	13	17	19	24	27	30	34	40	51
Net EER	kW / kW	3.5	3.4	3.3	3.0	3.0	2.9	3.0	2.8	2.6
Eurovent Energy class		A	A	A	A	A	B	A	B	C
Seasonal space efficiency	%	176	172	146	151	144	143	146	137	125
Operating outdoor air temperature range (min./max.)	(°C)	10 / 46	10 / 46	10 / 46	10 / 46	10 / 46	10 / 46	10 / 46	10 / 46	10 / 46
Operating outdoor air temperature range (min./max.) - Low ambient	(°C)	-15 / 46	-15 / 46	-15 / 46	-15 / 46	-15 / 46	-15 / 46	-15 / 46	-15 / 46	-15 / 46
<b>Performance data (heating mode)</b>										
Net heating capacity	(kW)	39	49	55	64	72	77	92	104	125
Total power input	(kW)	11	15	17	19	21	23	27	31	39
Net COP	kW / kW	3.4	3.4	3.2	3.3	3.4	3.3	3.4	3.3	3.2
Eurovent Energy class		A	B	B	B	A	B	A	B	B
Seasonal space efficiency	%	113	119	114	118	126	123	128	128	118
Operating outdoor air temperature range (min./max.)	(°C)	-15 / 20	-15 / 20	-15 / 20	-15 / 20	-15 / 20	-15 / 20	-15 / 20	-15 / 20	-15 / 20
<b>General data</b>										
A-weighted Outdoor sound power level (2)	(dB(A))	84	84	85	85	85	85	85	85	91
A-weighted sound power level in duct (2)	(dB(A))	75	78	82	80	84	87	92	96	99
Auxiliary electric heating capacity - Stage 1 / 2	(kW)	12,5 / 12,5	12,5 / 12,5	12,5 / 25	12,5 / 25	12,5 / 25	12,5 / 25	25 / 37,5	25 / 37,5	25 / 37,5
Auxiliary gas burner heating capacity	(kW)									
<b>Weights and dimensions (Operating)</b>										
Length	(mm)	3010	3010	3010	3010	3890	3890	3890	3890	3890
Width	(mm)	2250	2250	2250	2250	2250	2250	2250	2250	2250
Height	(mm)	1565	1565	1565	1565	1585	1585	1890	1890	1890
Weight (downflow - without options)	(kg)	1100	1112	1116	1153	1342	1348	1566	1570	1570
<b>Electrical Data</b>										
Power supply										
Maximum running amps	(A)	44	50	55	66	75	80	93	114	132
Start-up amps	(A)	80	93	113	129	161	168	204	233	253
Start-up amps (with soft starter)	(A)	65	75	89	102	126	132	159	184	202
<b>Additional amps per option</b>										
Electric Heater	(A)	36	36	54	54	54	54	90	90	90
Exhaust Fan (70pa)	(A)	1	1	1	1	1	1	1	1	1
Exhaust Fan (150pa)	(A)	1	1	1	1	2	2	2	2	2
Return Roofcurb	(A)	5	5	5	9	11	11	11	11	18
Energy Recovery Module (ERM)	(A)	8	8	8	8	8	8	8	8	8
<b>Supply fan data</b>										
Fan type		Plug Fan	Plug Fan	Plug Fan	Plug Fan	Plug Fan	Plug Fan	Plug Fan	Plug Fan	Plug Fan
Drive Type		EC Motors	EC Motors	EC Motors	EC Motors	EC Motors	EC Motors	EC Motors	EC Motors	EC Motors
Minimum Airflow	(m <sup>3</sup> /h)	6960	8480	9680	10960	12560	13360	15840	17280	20400
Nominal Airflow	(m <sup>3</sup> /h)	8700	10600	12100	13700	15700	16700	19800	21600	25500
Maximal Airflow	(m <sup>3</sup> /h)	11310	13780	15730	17810	20410	21710	25740	28080	33150
Number of fans	#	2	2	2	2	2	2	2	2	2
Motor Max Amps per fan	(A)	5	5	5	5	5	5	9	9	9
Motor Power - Standard drive (1)	(kW)	1.1	1.2	1.4	2.2	2.3	2.6	3.3	3.9	5.7
Motor Power - Oversized drive (1)	(kW)	1.1	1.2	1.4	2.1	2.3	2.7	3.3	3.2	4.5
Motor RPM at nominal flow rate - Standard drive (1)	RPM	1092	1242	1332	1573	1358	1426	1587	1682	1941
Motor RPM at nominal flow rate - Oversized drive (1)	RPM	1092	1242	1332	1281	1358	1423	1587	1295	1471
Available Static Pressure at nominal flow rate - Standard drive	(Pa)	250	250	250	250	250	250	250	250	250
Available Static Pressure at nominal flow rate - Oversized drive	(Pa)	500	500	500	500	500	500	500	500	500
<b>Condenser fan data</b>										
Fan type		Axial	Axial	Axial	Axial	Axial	Axial	Axial	Axial	Axial
Drive type - Standard ambient		AC motor	AC motor	AC motor	AC motor	AC motor	AC motor	AC motor	AC motor	AC motor
Drive type - Low ambient		EC motor	EC motor	EC motor	EC motor	EC motor	EC motor	EC motor	EC motor	EC motor
Number of fans per circuit	#	1	1	1	1	1	1	1	1	1
Motor Power	(kW)	0.7	0.7	0.7	0.7	0.7	0.7	0.7	0.7	1.3
Motor Max Amps per fan	(A)	2	2	2	2	2	2	2	2	3
Motor RPM	RPM	686	686	686	686	686	686	686	686	900

(1) At standard Eurovent rating conditions.

(2) Sound power levels were measured following the ISO 9614 as recommended by Eurovent requirement. All data are given according to standard EN 12102:2013.

# Dimensions and Weights

## Unit Dimensions (in mm)

### Frame 1 – Sizes 039 to 065 (Downflow)

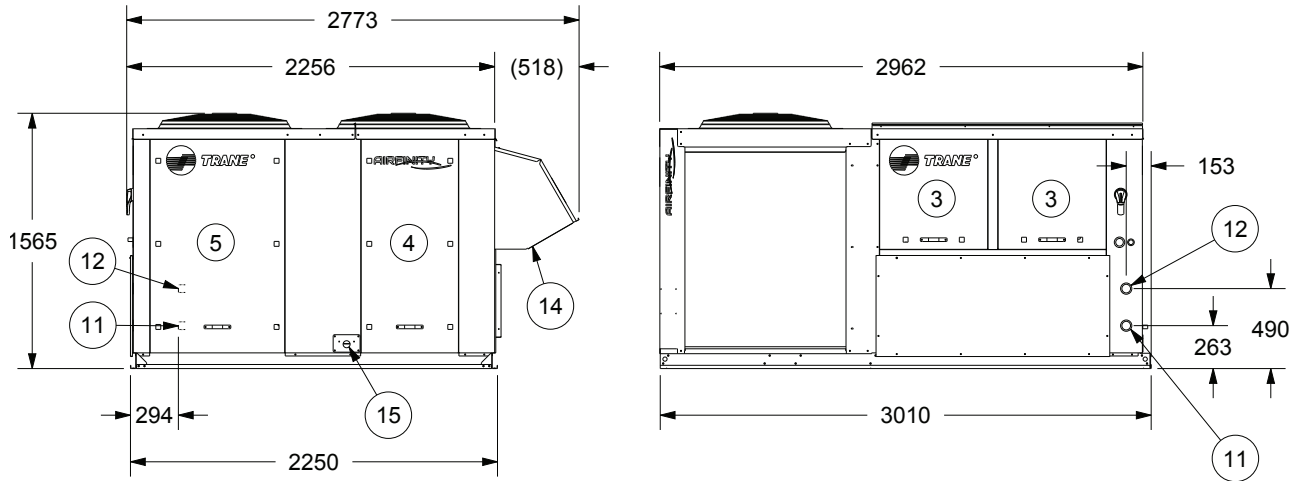

### Frame 2 – Sizes 074 to 085 (Downflow)

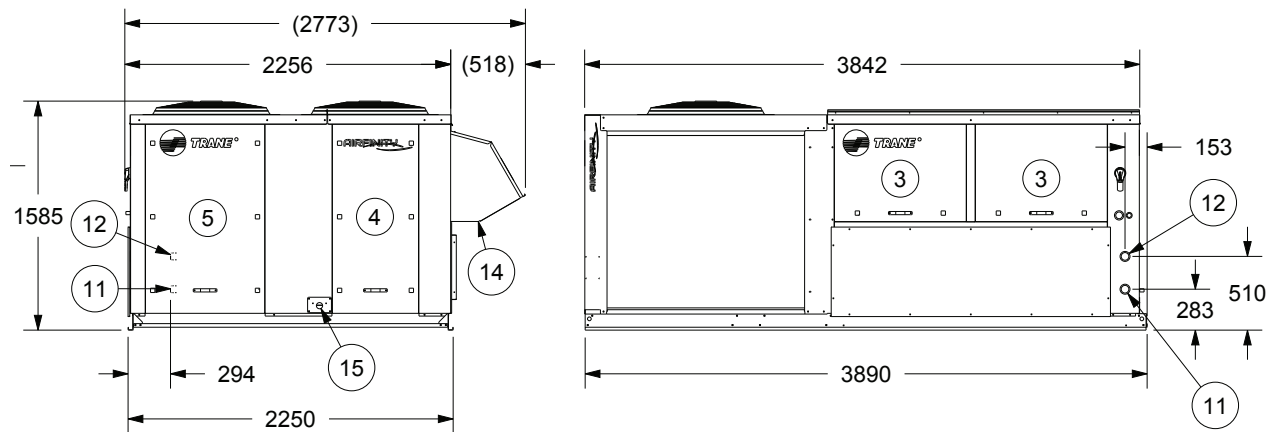

### Frame 3 – Sizes 100 to 130 (Downflow)

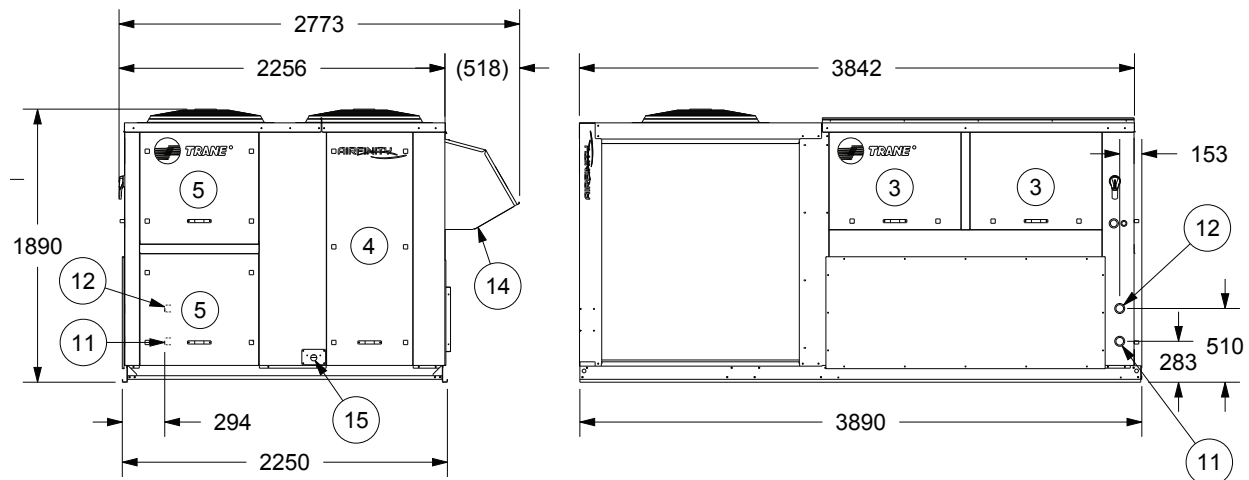



## Dimensions and Weights

### Energy Recovery Module dimensions (in mm)

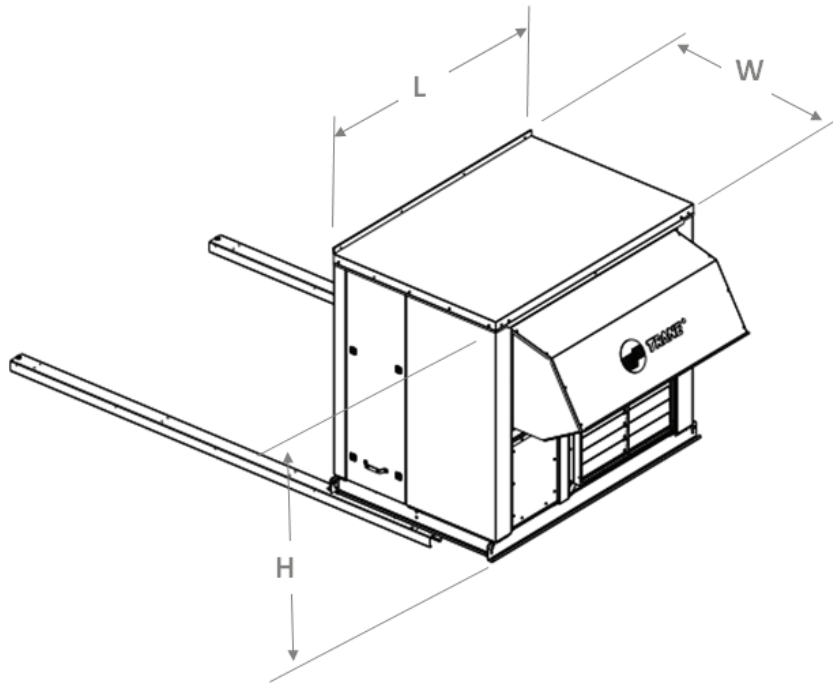

Frame	Models	L	W	H
ERM-01	039 to 065	1750	1180	1510
ERM-02	074 to 085	2250	1180	1530
ERM-03	100 to 130	2250	1180	1835

### Weights

	Basic unit		Additional weight per option or accessory							
	Operating Weight (Down-flow)	Shipping Weight (Down-flow)	Hot Water Coil	Electric Heater	Exhaust Fan	Return Roofcurb Down	Return Roofcurb Horizontal	Downflow Adjustable Roofcurb	Multidirectional Roofcurb	Energy recovery module
	kg	kg	kg	kg	kg	kg	kg	kg	kg	kg
IH039	983	1015	48	22	24	380	280	150	190	375
IH049	999	1031	48	22	24	380	280	150	190	375
IH059	1010	1042	48	22	24	380	280	150	190	375
IH064	1010	1042	48	22	24	390	290	150	190	375
IH040	1095	1127	48	22	24	380	280	150	190	375
IH050	1107	1139	48	22	24	380	280	150	190	375
IH060	1111	1143	48	22	24	380	280	150	190	375
IH064	1010	1042	48	22	24	380	280	150	190	375
IH065	1147	1179	48	22	24	390	290	150	190	375
IH075	1335	1367	59	26	39	470	350	170	220	455
IH085	1341	1373	59	26	39	470	350	170	220	455
IH100	1557	1589	65	29	43	470	350	170	220	535
IH110	1561	1593	65	29	43	470	350	170	220	535
IH130	1561	1593	65	29	43	490	370	170	220	535



# Acoustic data

Model	ESP (Pa)	Overall outdoor sound power level (dB(A)) Spectrum per octave band at full load								Sound pressure at 10 m dB (A)	
		63 Hz	125 Hz	250 Hz	500 Hz	1000 Hz	2000 Hz	4000 Hz	8000 Hz	Global dBA	Lp
IH039	100	53	63	73	79	82	78	73	64	85	54
IH040	100	60	70	74	79	81	74	69	64	84	53
IH049	100	53	63	73	79	81	78	73	65	85	54
IH050	100	60	70	74	79	81	74	69	66	84	53
IH059	100	53	63	73	79	81	78	73	64	85	54
IH060	100	60	70	74	79	82	75	70	66	85	54
IH064	100	53	63	73	79	82	78	75	66	85	54
IH065	100	60	70	74	79	81	75	73	69	85	54
IH074	100	60	70	75	79	83	78	69	58	86	54
IH075	100	60	70	74	79	82	76	73	64	85	53
IH084	100	60	70	75	80	82	80	73	52	86	54
IH085	100	60	70	74	79	82	76	72	63	85	53
IH100	100	60	70	74	79	81	75	73	66	85	53
IH110	100	60	70	74	79	81	76	74	66	85	53
IH130	100	59	69	78	83	88	83	78	70	91	59

## Unit with standard drive (250 Pa)

Model	ESP (Pa)	Supply indoor sound power level dB(A) Spectrum per octave band at full load								Global dBA
		63 Hz	125 Hz	250 Hz	500 Hz	1000 Hz	2000 Hz	4000 Hz	8000 Hz	
IH039	85	71	71	72	76	73	80	72	58	83
IH040	85	62	65	65	67	68	66	65	62	75
IH049	110	70	77	77	79	77	80	85	63	88
IH050	110	65	68	69	70	72	70	69	66	78
IH059	110	71	82	79	82	86	80	90	71	93
IH060	110	68	72	73	74	76	73	72	72	82
IH064	110	74	84	81	84	89	83	95	77	97
IH065	110	74	70	70	76	73	76	69	60	80
IH074	110	73	74	73	77	75	79	75	62	84
IH075	110	73	74	73	77	75	79	75	62	84
IH084	135	70	78	76	79	77	80	82	65	87
IH085	135	70	78	76	79	77	80	82	65	87
IH100	135	72	80	80	82	83	82	88	69	92
IH110	150	74	84	82	85	90	83	93	73	96
IH130	150	77	87	84	87	92	86	97	80	99

Model	ESP (Pa)	Return indoor sound power level dB(A) Spectrum per octave band at full load								Global dBA
		63 Hz	125 Hz	250 Hz	500 Hz	1000 Hz	2000 Hz	4000 Hz	8000 Hz	
IH039	85	67	69	72	68	67	80	69	56	81
IH040	85	50	63	65	62	60	59	61	62	71
IH049	110	67	72	75	71	71	79	84	62	86
IH050	110	53	67	69	65	64	63	64	66	74
IH059	110	68	79	80	75	76	77	89	69	91
IH060	110	57	70	73	70	67	67	68	72	78
IH064	110	69	79	84	78	79	79	94	76	95
IH065	110	71	69	69	66	67	75	65	57	77
IH074	110	69	71	72	68	69	78	71	59	81
IH075	110	69	71	72	68	69	78	71	59	81
IH084	135	67	75	74	70	71	78	79	63	84
IH085	135	67	75	74	70	71	78	79	63	84
IH100	135	69	76	79	75	75	79	86	67	89
IH110	150	70	80	83	78	79	79	92	72	93
IH130	150	73	81	86	81	82	82	97	78	98

## Acoustic data

### Unit with oversized drive (500 Pa)

Supply indoor sound power level dB(A) Spectrum per octave band at full load										
Model	ESP (Pa)	63 Hz	125 Hz	250 Hz	500 Hz	1000 Hz	2000 Hz	4000 Hz	8000 Hz	Global dBA
IH039	500	75	75	76	80	77	84	76	62	87
IH040	500	68	71	71	73	74	72	71	68	81
IH049	500	73	80	80	82	80	83	88	66	91
IH050	500	70	73	74	75	77	75	74	71	83
IH059	500	74	85	82	85	89	83	93	74	96
IH060	500	72	76	77	78	80	77	76	76	86
IH064	500	76	86	83	86	91	85	97	79	99
IH065	500	78	74	74	80	77	80	73	64	84
IH074	500	77	78	77	81	79	83	79	66	88
IH075	500	77	78	77	81	79	83	79	66	88
IH084	500	74	82	80	83	81	84	86	69	91
IH085	500	74	82	80	83	81	84	86	69	91
IH100	500	75	83	83	85	86	85	91	72	95
IH110	500	77	87	85	88	93	86	96	76	99
IH130	500	79	89	86	89	94	88	99	82	101

Return indoor sound power level dB(A) Spectrum per octave band at full load										
Model	ESP (Pa)	63 Hz	125 Hz	250 Hz	500 Hz	1000 Hz	2000 Hz	4000 Hz	8000 Hz	Global dBA
IH039	500	71	73	76	72	71	84	73	60	85
IH040	500	56	69	71	68	66	65	67	68	77
IH049	500	70	75	78	74	74	82	87	65	89
IH050	500	58	72	74	70	69	68	69	71	79
IH059	500	71	82	83	78	79	80	92	72	94
IH060	500	61	74	77	74	71	71	72	76	82
IH064	500	71	81	86	80	81	81	96	78	97
IH065	500	75	73	73	70	71	79	69	61	81
IH074	500	73	75	76	72	73	82	75	63	85
IH075	500	73	75	76	72	73	82	75	63	85
IH084	500	71	79	78	74	75	82	83	67	88
IH085	500	71	79	78	74	75	82	83	67	88
IH100	500	72	79	82	78	78	82	89	70	92
IH110	500	73	83	86	81	82	82	95	75	96
IH130	500	75	83	88	83	84	84	99	80	100



Trane optimizes the performance of homes and buildings around the world. A business of Ingersoll Rand, the leader in creating and sustaining safe, comfortable and energy efficient environments, Trane offers a broad portfolio of advanced controls and HVAC systems, comprehensive building services and parts. For more information visit [www.Trane.com](http://www.Trane.com)

Trane has a policy of continuous product and product data improvement and reserves the right to change design and specifications without notice.

© 2017 Trane All rights reserved  
RT-PRC082A-GB January 2017  
New

We are committed to using environmentally  
conscious print practices that reduce waste.

