



Installation Operation Maintenance

**AquaStream™ 3G air-cooled liquid chillers
Models CGAM**



September 2011

CG-SVX19C-E4

Contents

General information	3
Model number	5
Unit description	9
Pre-installation	10
General data	12
Dimensions	48
Installation – Mechanical	54
Water Pressure Drops	60
Operating map	63
Installation – Electrical	64
Communications Interface Options	71
Operating principles	73
Partial Heat Recovery	77
Total Heat Recovery	79
Controls Interface	85
Pre-start checkout	86
Unit Start-up procedures	87
Unit Shut-down procedures	91
Maintenance	92
Compressor Service Information	94

General information

Foreword

These instructions are given as a guide to good practice in the installation, start-up, operation, and maintenance by the user, of Trane CGAM chillers. They do not contain full service procedures necessary for the continued successful operation of this equipment. The services of a qualified technician should be employed through the medium of a maintenance contract with a reputable service company. Read this manual thoroughly before unit start-up.

Units are assembled, pressure tested, dehydrated, charged and run tested before shipment.

Warnings and cautions

Warnings and Cautions appear at appropriate sections throughout this manual. Your personal safety and the proper operation of this machine require that you follow them carefully. The constructor assumes no liability for installations or servicing performed by unqualified personnel.

WARNING!: Indicates a potentially hazardous situation which, if not avoided, could result in death or serious injury.

CAUTION!: Indicates a potentially hazardous situation which, if not avoided, may result in minor or moderate injury. It may also be used to alert against unsafe practices or for equipment or property-damage-only accidents.

Safety recommendations

To avoid death, injury, equipment or property damage, the following recommendations should be observed during maintenance and service visits:

1. The maximum allowable pressures for system leak testing on low and high pressure side are given in the chapter "Installation". Always provide a pressure regulator.
2. Disconnect the main power supply before any servicing on the unit.
3. Service work on the refrigeration system and the electrical system should be carried out only by qualified and experienced personnel.

Proper servicing of the service valves is required. Use a backup wrench as shown in Figure 1 when loosening or tightening the service valve cap.

Figure 1 - Servicing of service valves

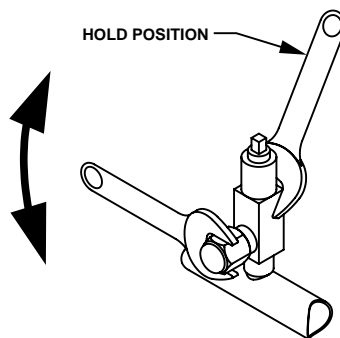

Reception

On arrival, inspect the unit before signing the delivery note.

Reception in France only:

In case of visible damage: The consignee (or the site representative) must specify any damage on the delivery note, legibly sign and date the delivery note, and the truck driver must countersign it. The consignee (or the site representative) must notify Trane Epinal Operations - Claims team and send a copy of the delivery note. The customer (or the site representative) should send a registered letter to the last carrier within 3 days of delivery.

Note: for deliveries in France, even concealed damage must be looked for at delivery and immediately treated as visible damage.

Reception in all countries except France:

In case of concealed damage: The consignee (or the site representative) must send a registered letter to the last carrier within 7 days of delivery, claiming for the described damage. A copy of this letter must be sent to Trane Epinal Operations - Claims team.

Warranty

Warranty is based on the general terms and conditions of the manufacturer. The warranty is void if the equipment is repaired or modified without the written approval of the manufacturer, if the operating limits are exceeded or if the control system or the electrical wiring is modified. Damage due to misuse, lack of maintenance or failure to comply with the manufacturer's instructions or recommendations is not covered by the warranty obligation. If the user does not conform to the rules of this manual, it may entail cancellation of warranty and liabilities by the manufacturer.

General information

The following pictograms can be found on the unit. Take necessary precautions to avoid damage and injury.

Figure 2 - Warning pictograms

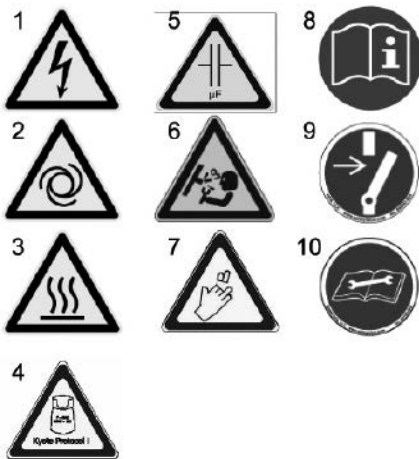

- 1 = Risk that unit is powered up
- 2 = Risk hazard due to fan rotation
- 3 = Risk hazard of burns on compressors or refrigeration piping
- 4 = Unit contains refrigerant gas. See specific warnings.
- 5 = Risk of residual voltage when speed drive or softstarter options are present
- 6 = Unit under pressure
- 7 = Risk to cut, particularly on heat exchanger fins
- 8 = Read instructions before installation
- 9 = Disconnect all electric power before servicing
- 10 = Read technical instructions

Refrigerant

The refrigerant provided by the manufacturer meets all the requirements of our units. When using recycled or reprocessed refrigerant, it is advisable to ensure its quality is equivalent to that of a new refrigerant. For this, it is necessary to have a precise analysis made by a specialized laboratory. If this condition is not respected, the manufacturer warranty could be cancelled.

Environmental Protection / Compliance with F-Gas regulation

This equipment contains a fluorinated gas covered by the Kyoto Protocol [or an ozone depleting substance covered by Montreal Protocol]. The type and quantity of refrigerant per circuit is indicated on the product nameplate. The Global Warming Potential of the refrigerant implemented in Trane Air Conditioning and Refrigeration Equipment is presented in the table by type of refrigerant.

Refrigerant type	GWP (1) value
R134a	1 300
R407C	1 653
R410A	1 975
R404A	3 784
R22 (2)	1 780

The operator (contractor or end user) must check local environmental regulations impacting installation, operation and disposal of the equipment; in particular need to recover environmentally harmful substances (refrigerant, oil, antifreeze agents, etc.) Do not vent into the atmosphere any refrigerant. The handling of refrigerant shall be fulfilled by a qualified service engineer.

(1) GWP = global warming potential
(2) Covered by Montreal Protocol

Maintenance contract

It is strongly recommended that you sign a maintenance contract with your local Service Agency. This contract provides regular maintenance of your installation by a specialist in our equipment. Regular maintenance ensures that any malfunction is detected and corrected in good time and minimizes the possibility that serious damage will occur. Finally, regular maintenance ensures the maximum operating life of your equipment. We would remind you that failure to respect these installation and maintenance instructions may result in immediate cancellation of the warranty.

Training

To assist you in obtaining the best use of it and maintaining it in perfect operating condition over a long period of time, the manufacturer has at your disposal a refrigeration and air conditioning service school. The principal aim of this is to give operators and technicians a better knowledge of the equipment they are using, or that is under their charge. Emphasis is particularly given to the importance of periodic checks on the unit operating parameters as well as on preventive maintenance, which reduces the cost of owning the unit by avoiding serious and costly breakdown.

Model number

Unit nameplate

The unit nameplates are applied to the exterior surface of the control panel door. A compressor nameplate is located on each compressor.

The unit nameplate provides the following information:

- Unit model and size descriptor.
- Unit serial number
- Identifies unit electrical requirements.
- Lists correct operating charges of R410A and refrigerant oil.
- Lists unit test pressures

Figure 3 - Unit nameplate

TYPE	[]		
①	CRC	N° SERIE ②	CCYY
	[]	[]	[]
	N° ORGANISME NOTIFIE ③		
	[]	[]	[]
	QTE-QTY	V / Hz / Ph	A max / FLA
	C1 []	[]	[]
	C2 []	[]	[]
	[]	[]	[]
	[]	[]	[]
CONTROLE – CONTROL	[]	[]	VA
INTENSITE DEMARRAGE – STARTING AMPS	[]	[]	[]
FLUIDE ④	[]	kg	kg
	[]	C1/C2 []	l
PS	BP-LP []	bar	HP-HP []
	[]	bar	[]

EN / DE / IT / ES / DA / FI / NL / NO / PT / SV / CZ / PO / HU / EL / HR / SK / SL / TR / ET / LT / LV / BG / RO / RU / UK

① Type / Тип / Tipo / Type / Type / Τυπός / Type / Type / Tipo / Typ / Typ / Typ / Típus / Τύπου / Tip / Tytu / Tip / Tip / Tüüp / Típas / Típs / типа / тип / тип

② Serial nb / Seriennummer / Numero di serie / Numero de série / Seriennummer / Sarjanumero / Seriennummer / Seriennummer / Numero di serie / Tillverkningsnummer / Sériové číslo / Number fabryczny / Sorozat szám / Αριθμός σειράς / Serijski broj / výrobné číslo / Serijska številka / Seri no / Seeria number / Serijinis numeris / Sérijas Nr. / заводски номер, / numărul de fabricație / серийный номер / серийний номер

③ Notified body / Benannte Stelle / Organismo notificato / Organismo notificado / Bemyndiget organ / Ilmottettujen laitosten / Aangemelde Instantie / Ramme nr. / Organismo notificado / Anmält organ / Autorizovaná osoba / Organizacja notyfikowana / Regisztráció száma / Σώμα γνωστοποίησης / Ovlaštена osoba / Oboznámený orgán / Pooblaščena oseba / Kurum Onay No / Katsetav osa / Notifikuota organizacija / pilnvarotā iestāde / нотифицирания орган / organismului notificat / уполномоченный орган / уповноважена особа

④ Fluid / Fluide / Fluido / Fluido / Fluidum / Fluidi / Stof / Kuldemedium / Fluido / Fluid / Kapalina / Czynniki / Közeg / ρευστό / Medij / tekutin / Tekočina / Akiskan / Vedelik / Šaldymo agentas / Šķidrums / флуиди / Fluid / жидкость / рідина

88130 CHARMES – FRANCE
For TRANE BVBA

CE

X39001421-001 / A5

Model number

Digit 1-4 – Chiller Model

CGAM = Air-Cooled Scroll
Packaged Chiller

Digit 5-7 – Unit Nominal Tonnage

020 = 20 Tons
023 = 23 Tons
026 = 26 Tons
030 = 30 Tons
035 = 35 Tons
039 = 39 Tons
040 = 40 Tons
045 = 45 Tons
046 = 46 Tons
050 = 50 Tons
052 = 52 Tons
060 = 60 Tons
070 = 70 Tons
080 = 80 Tons
090 = 90 Tons
100 = 100 Tons
110 = 110 Tons
120 = 120 Tons
140 = 140 Tons
150 = 150 Tons
160 = 160 Tons
170 = 170 Tons

Digit 8 – Unit Voltage

E = 400 Volt 50 Hz 3 Phase

Digit 9 – Manufacturing Plant

1 = Epinal, France

Digit 10-11 – Design Sequence

A-Z = Factory/ABU Assigned

Digit 12 – Unit Type

1 = Standard Efficiency/
Performance
2 = High Efficiency/Performance

Digit 13 – Agency Listing

B = CE Certification (EUR)

Digit 14 – Pressure Vessel Code

4 = Europe Standard

Digit 15 – Unit Application

A = Standard Ambient (32-115F/0-46C)
B = High Ambient (up to-52C)
C = Low Ambient (0 to 115/-18 to 46C)
D = Wide Ambient (-18 to 52C)

Digit 16 – Refrigerant Isolation Valves

1 = No Isolation Valves

Digit 17

A

Digit 18 – Freeze Protection (Factory-Installed Only)

X = Without Freeze Protection
2 = With Freeze Protection (CH530 Control)

Digit 19 – Insulation

A = Factory Insulation - All Cold Parts

Digit 20 – Factory Charge

1 = Full Factory Refrigerant Charge (HFC-410A)

Digit 21 – Evaporator Application

A = Standard Cooling (5.5 to 18°C)
B = Low Temperature Processing (lower than 5.5°C)
C = Ice-Making - hardwired interface (-7 to 18°C)

Digit 22 – Water Connection (Evap)

1 = Grooved Pipe Connection
2 = Grooved Pipe with Flange Adapter

Digit 23 – Condenser Fin Material

A = Lanced Aluminum Fins
B = Non-Lanced Aluminum Fins
E = Non-Lanced Aluminum Fins w/ Pre-Coat (Black Epoxy)

Digit 24 – Condenser Heat Recovery

X = No Heat Recovery
2 = Partial Heat Recovery w/o Fan Control
3 = Full Heat Recovery

Digit 25

X

Digit 26 – Starter Type

A = Across the Line Starter/Direct on Line
B = Solid State Soft Starter
C = Across the Line Starter/Power Factor Correction

Digit 27 – Incoming Power Line Connection

1 = Single Point Power Connection

Digit 28 – Power Line Connection Type

B = Disconnect Switch

Digit 29 – Enclosure Type

2 = IP54 Protection

Digit 30 – Unit Operator Interface

A = Dyna-View/English
B = Dyna-View/Spanish-Spain
D = Dyna-View/French
E = Dyna-View/German
F = Dyna-View/Dutch
G = Dyna-View/Italian
J = Dyna-View/Portuguese-Portugal
R = Dyna-View/Russian
T = Dyna-View/Polish
U = Dyna-View/Czech
V = Dyna-View/Hungarian
W = Dyna-View/Greek
Y = Dyna-View/Romanian
Z = Dyna-View/Swedish

Model number

Digit 31 — Remote Interface (digital comm)

- X = No Remote Digital Communication
- 1 = LonTalk LCI-C Interface with Modbus Interface
- 2 = LonTalk/Tracer Summit Interface
- 3 = Time of Day Scheduling
- 4 = BACNet Interface

Digit 32 — Ext. Chilled/Hot Water and Curr. Demand Limit Setpoint

- X = No Ext. Chilled Water Setpoint
- A = Ext Chilled Water and Demand Limit Setpoint - 4-20mA
- B = Ext Chilled Water and Demand Limit Setpoint - 2-10Vdc
- C = Auxiliary setpoint

Digit 33 — % Capacity

- X = Without % Capacity
- 1 = With % Capacity

Digit 34 — Programmable Relays

- X = No Programmable Relays
- A = Programmable Relays

Digit 35 — Pump Type

- X = No Pumps and no Contactors
- 1 = No Pumps w/ Single Contactors
- 2 = No Pumps w/ Dual Contactors
- 3 = No Pumps w/ Single Contactors Single High Head Pump
- 4 = No Pumps w/ Dual Contactors Dual High Head Pump
- 5 = Single Standard Head Pump
- 6 = Single High Head Pump
- 7 = Dual Standard Head Pump
- 8 = Dual High Head Pump

Digit 36 — Pump Flow Control

- X = No Pump Flow Control

- A = Pump Flow Controlled by Triple Duty Valve

- B = Pump Flow Controlled by Variable Speed Drive

Digit 37 — Buffer Tank

- X = No Tank
- 1 = With Tank

Digit 38 — Short Circuit Rating

- A = Default A Short Circuit Rating

Digit 39 — Installation Accessories

- 1 = Elastomeric Isolators
- 4 = Neoprene Pads

Digit 40 — Water Strainer

- X = No Strainer
- A = With Water Strainer Factory-Installed

Digit 41 — Sound Attenuator Package

- 1 = Compact
- 3 = Super Quiet
- 4 = Super Quiet with Night Noise Setback
- 5 = Comprehensive Acoustic Package

Digit 42 — Appearance Options

- X = No Appearance Options
- A = Architectural Louvered Panels
- B = Half Louvers
- C = Access Guards
- D = Access Guards and Half Louvers

Digit 43

- X

Digit 44 — Label and Literature Language

- A = Bulgarian
- B = Spanish and English
- C = German
- D = English
- E = French
- H = Dutch SI (Hollandais)

- J = Italian

- L = Danish

- M = Swedish

- N = Norwegian

- P = Polish

- R = Russian

- T = Czech

- U = Greek

- V = Portuguese

- Y = Romanian

- Z = Serbian

- 1 = Slovak

- 2 = Croatian

- 3 = Hungarian

Digit 45 — Enhanced phase monitoring

- X = Not installed
- 1 = Installed

Digit 46 — Shipping Package

- X = No Skid (Standard)
- A = Unit Containerization Package

Digit 47

- X

Digit 48 — Flow switch setpoint

- C = Setpoint 15
- F = Setpoint 35
- H = Setpoint 45
- L = Setpoint 60

Digit 49

- X

Digit 50 — Specials

- X = None
- S = Special

Notes:

1. If a digit is not defined it may be held for future use.

Model number

The compressor nameplate provides the following information:

- Compressor model number.
- Compressor serial number.
- Compressor electrical characteristics.
- Utilization range.
- Recommended refrigerant.

Digit 8 – Voltage

J - 200-230/3/60

K - 460/3/60-400/3/50

F - 230/3/50

D - 575/3/60

X - 380/3/60

Y - 200/3/50 (CSHD 125 only)

Model Number Coding System

The model numbers for the unit and the compressors are comprised of numbers and letter which represent features of the equipment. Each position, or group of positions, in the number is used to represent a feature. For example, Unit Voltage, contains the letter “E”. From the chart, it can be seen that an “E” in this position means that the unit voltage is 400/50/3.

Digit 9 – Unloading

(0 – no unloading)

Digit 10 – Design Sequence

Digit 11 – Protection Module Voltage

0 - Int Line Break- CSHD

A - 115 VAC

B - 230 VAC

H - 24 VAC

K - 115/230 VAC – CSHN

Compressor Model Number (located on compressor nameplate)

Digit 1,2,3,4

CSHD - Light Commercial

CSHN - Commercial

Digit 12 – Basic Compressor Variation

M - Suction & Discharge Tube, oil equalizer with seal nut, Grade 32 POE oil

Digit 5,6,7 – Capacity- 60 Hz ARI
KBtu/Hr (approximate)

125 - CSHD

161 - CSHD

184 - CSHN

250 - CSHN

315 - CSHN

374 - CSHN

Unit description

Units are scroll type, air-cooled, liquid chillers, designed for installation outdoors. The units have one or two independent refrigerant circuits, two or more compressors per circuit. Units are packaged with an evaporator and condenser.

Note: Each unit is a completely assembled, hermetic package that is factory-piped, wired, leak-tested, dehydrated, charged and tested for proper control operations prior to shipment. The chilled water inlet and outlet openings are covered for shipment.

Units feature Trane's exclusive Adaptive Control logic with CH530 controls. It monitors the control variables that govern the operation of the chiller unit. Adaptive Control logic can correct these variables, when necessary, to optimize operational efficiencies, avoid chiller shutdown, and keep producing chilled water.

Each refrigerant circuit is provided with filter, sight glass, electronic expansion valve, and charging valves.

The evaporator is a brazed plate and frame heat exchanger which is equipped with water drain and vent connections. The condenser is an air-cooled fin coil.

The condensers are available in three configurations depending on the tonnage of the unit. Units may be referred to the size by the condenser configuration. The three configurations are slant, V and W.

Accessory/options information

Check all the accessories and loose parts which are shipped with the unit against the original order. Included in these items will be rigging diagrams, electrical diagrams, and service literature, which are placed inside the control panel and/or starter panel for shipment. Also check for optional components, such as flange adapters and isolators.

The unit isolators and the flange adapter ship on brackets attached to the frame of the unit.

Pre-installation

Inspection checklist

When the unit is delivered, verify that it is the correct unit and that it is properly equipped. Compare the information which appears on the unit nameplate with the ordering and submittal information.

Inspect all exterior components for visible damage. Report any apparent damage or material shortage to the carrier and make a "unit damage" notation on the carrier's delivery receipt. Specify the extent and type of damage found and notify the appropriate Trane Sales Office. Do not proceed with installation of a damaged unit without sales office approval.

Mandatory Start-up Checklist

***This checklist is not intended to be a substitution for the contractors installation instruction. This checklist is intended to be a guide for the Trane technician just prior to unit 'start-up'. Many of the recommended checks and actions could expose the technician to electrical and mechanical hazards. Refer to the appropriate sections in the unit manual for appropriate procedures, component specifications and safety instructions.

Except where noted; it is implied that the technician is to use this checklist for inspection / verification of prior task completed by the general contractor at installation.

1. Unit clearances adequate for service and to avoid air recirculation, etc.
2. Unit exterior inspected
3. Crankcase heaters working for 24 hours prior to arrival of Trane technician performing start up
4. Correct voltage supplied to unit and electric heaters (imbalance not to exceed 2%)
5. Unit power phasing (A-B-C sequence) proper for compressor rotation

6. Copper power wiring meets sizing requirement in job submittal
7. Unit properly grounded
8. All automation and remote controls installed/wired
9. All wiring connections tight
10. Prove chilled water side Interlock and Interconnecting Wiring Interlock and externals (chilled water pump)
11. Field installed control wiring landed on correct terminals (external start/stop, emergency stop, chilled water reset...)
12. Shipping hardware for compressors removed
13. Verify all refrigerant and oil valves are open/back seated
14. Compressor oil levels (1/2 -3/4 high in glass) proper
15. Verify chilled water strainer is clean and free of debris and evaporator chilled water circuits are filled
16. Close the fused-disconnect switch(es) that supplies power to the chilled water pump starter
17. Start the chilled water pump to begin circulation of the water. Inspect piping for leaks and repair as necessary
18. With water circulating through the system, adjust water flow and check water pressure drop through evaporator
19. Adjust the chilled water flow switch for proper operation
20. Return chilled water pump to auto
21. Verify all CH530 Menu Items on DynaView and KestrelView
22. Fan amperages within nameplate specs
23. All panels/doors secured prior to start-up
24. All coil fins inspected and straightened
25. Rotate fans before starting unit to inspect for potential audible and visual signs of rubbing. Start unit
26. Press AUTO key. The unit will start if the chiller control calls for cooling and the safety interlocks are closed
27. Check the EXV sight glasses after sufficient time has elapsed allowing entering and leaving water to stabilize
28. Check the evaporator and the condenser refrigerant pressure under Refrigerant Report on CH530 TechView
29. Confirm Superheat and subcooling values are normal
30. Compressor operation normal and within amperage rating
31. Operating log completed
32. Press stop key
33. Inspect fans again after being under load to ensure no signs or rubbing exist
34. Verify the chilled water pump runs for at least 1 minute after the chiller is commanded to stop (for normal chilled water systems)

Unit storage

If the chiller is to be stored for more than one month prior to installation, observe the following precautions:

- Store the chiller in a dry, vibration-free, secure area.
- Units charged with refrigerant should not be stored where temperatures exceed 68°C.
- At least every three months, attach a gauge and manually check the pressure in the refrigerant circuit. If the refrigerant pressure is below 13 bar at 20°C (or 10 bar at 10°C), call a qualified service organization and the appropriate Trane sales office.

Installation requirements and contractor responsibilities

A list of the contractor responsibilities typically associated with the unit installation process is provided.

Pre-installation

Type of requirement	Trane-supplied Trane-installed	Trane-supplied Field-installed	Field-supplied Field-installed
Foundation			Meet foundation requirements
Rigging			<ul style="list-style-type: none"> • Safety chains • Clevis connectors • Lifting beams
Isolation		Isolation pads or neoprene isolators (optional)	Isolation pads or neoprene isolators (optional)
Electrical	<ul style="list-style-type: none"> • Disconnect switch • Unit mounted starter 		<ul style="list-style-type: none"> • Wiring sizes per submittal and local codes and regulations • Terminal lugs • Ground connection(s) • BAS wiring (optional) • Control voltage wiring <ul style="list-style-type: none"> • Chilled water pump contactor and wiring including interlock • Option relays and wiring
Water piping	<ul style="list-style-type: none"> • Flow switch • Water strainer (option) 		<ul style="list-style-type: none"> • Taps for thermometers and gauges • Thermometers • Water flow pressure gauges • Isolation and balancing valves in water piping • Vents and drain • Pressure relief valves
Insulation	<ul style="list-style-type: none"> • Insulation 		<ul style="list-style-type: none"> • Insulation
Water piping connection components	<ul style="list-style-type: none"> • Grooved pipe 	<ul style="list-style-type: none"> • Flange adapters 	

General Data

Table 1 - CGAM - Standard Efficiency Compact - SIMPLEX units

Size		20	23	26	30	35	39	45	50
Eurovent Performances (1)									
Net capacity	(kW)	55.5	63.2	69.8	79.8	91.4	110.1	122.1	133.8
Total power input	(kW)	20.4	22.1	25.2	29.7	34.3	39.7	44.3	50.4
EER		2.72	2.86	2.77	2.68	2.66	2.77	2.76	2.65
Main power supply		400/3/50	400/3/50	400/3/50	400/3/50	400/3/50	400/3/50	400/3/50	400/3/50
Sound power level	(dBA)	88.8	88.8	89.0	89.7	91.7	93.7	92.7	91.7
System Data									
Refrigerant circuit	#	1	1	1	1	1	1	1	1
Capacity steps	%	50-100	43-100	50-100	50-100	43-100	50-100	44-100	50-100
Units Amps (2)									
Maximum amps	(A)	48.5	53.5	58.5	69.3	78.5	91.2	102.6	114.1
Start-up amps - standard unit	(A)	170.4	186.4	191.4	198.8	253.8	266.4	311.4	322.9
Start-up amps - with soft starter option	(A)	98.4	116.4	121.4	145.8	177.8	190.4	230.4	241.9
Short circuit unit capacity	(kA)	15	15	15	15	15	15	15	15
Min supply cable size	(mm ²)	50	50	50	50	95	95	95	95
Max supply cable size	(mm ²)	95	95	95	95	150	150	150	150
Compressor									
Number	#	2	2	2	2	2	2	2	2
Type		Scroll	Scroll	Scroll	Scroll	Scroll	Scroll	Scroll	Scroll
Model		CSHD125& CSHD125	CSHD125& CSHD161	CSHD161& CSHD161	CSHN184& CSHN184	CSHN184& CSHN250	CSHN250& CSHN250	CSHN250& CSHN315	CSHN315& CSHN315
Motor RPM	(rpm)	2900	2900	2900	2900	2900	2900	2900	2900
Power factor	#	0.85	0.85	0.85	0.85	0.85	0.85	0.85	0.85
Sump heater per circuit	(W)	90&90	90&90	90&90	160&160	160&160	160&160	160&160	160&160
Evaporator									
Quantity	#	1	1	1	1	1	1	1	1
Type		BPHE	BPHE	BPHE	BPHE	BPHE	BPHE	BPHE	BPHE
Water volume/storage (total)	(L)	4.0	4.0	4.0	6.7	6.7	10.6	10.6	13.3
Antifreeze heater	(W)			120 W				180 W	
Min. flow	(L/Sec)	1.3	1.5	1.6	1.9	2.1	2.6	2.9	3.1
Max. flow	(L/Sec)	3.9	4.4	4.9	5.6	6.4	7.8	8.6	9.4
Pump Package (Option Standard Head)									
Nb Pump Set	#	1	1	1	1	1	1	1	1
Motor RPM	(rpm)	2860	2860	2860	2860	2860	2890	2890	2890
Pump power (single / dual) - standard head	(kW)	1.5	1.5	1.5	1.5	1.5	3.0	3.0	3.0
Rated amps (single / dual) - standard head	(A)	3.25	3.25	3.25	3.25	3.25	6.1	6.1	6.1
Pump power (single / dual) - high head	(kW)	4.0	4.0	4.0	4.0	5.5	5.5	5.5	5.5
Rated amps (single / dual) - high head	(A)	7.59	7.59	7.59	7.59	10.6	10.6	10.6	10.6
Hydraulic Module Components									
Expansion tank volume	(L)	25	25	25	25	25	25	25	25
User volume expansion capacity	(L)	380	380	380	380	380	380	380	380

General Data

Size		20	23	26	30	35	39	45	50
Max. Water-side pressure without pump	(kPa)	1000	1000	1000	1000	1000	1000	1000	1000
Max. Water-side pressure with pump	(kPa)				400				
Antifreeze heater	(W)				180				
Pump package antifreeze heater	(W)				530				
Water tank antifreeze heater	(W)				860				
Water tank volume	(L)				500				
Condenser									
Type		Fin and Tube	Fin and Tube	Fin and Tube	Fin and Tube	Fin and Tube	Fin and Tube	Fin and Tube	Fin and Tube
Qty of coils	#	1	1	1	1	1	1	1	1
Fan									
Type		Propeller	Propeller	Propeller	Propeller	Propeller	Propeller	Propeller	Propeller
Quantity per circuit	#	2	2	2	2	2	3	3	3
Diameter	(mm)	732	732	732	732	732	732	732	732
Drive type		Direct	Direct	Direct	Direct	Direct	Direct	Direct	Direct
Airflow per fan	(m ³ /h)	13486	16114	16120	16129	17637	16087	17188	17194
Static pressure	(Pa)	0	0	0	0	0	0	0	0
Motor rpm	#	920	920	920	920	920	920	920	920
Unit Water Connection									
Chilled water	(mm)	50	50	50	65	65	65	65	65
Type (standard)		Grooved	Grooved	Grooved	Grooved	Grooved	Grooved	Grooved	Grooved
Dimensions									
Unit length with buffer tank	(mm)	3418	3418	3418	3418	3418	4332	4332	4332
Unit length without buffer tank	(mm)	2908	2908	2908	2908	2908	3822	3822	3822
Unit width	(mm)	1280	1280	1280	1280	1280	1280	1280	1280
Unit height	(mm)	2145	2145	2145	2145	2145	2145	2145	2145
Weight									
Operating weight(3)	(kg)	855	873	877	978	992	1147	1208	1267
Shipping weight(3)	(kg)	828	846	850	949	962	1113	1175	1231
Additional weight (single pump standard head)	(kg)	154	153	153	153	155	199	198	207
Additional weight (dual pump standard head)	(kg)	183	183	184	183	184	232	231	250
Additional weight (single pump high head)	(kg)	163	163	162	162	167	209	208	208
Additional weight (dual pump high head)	(kg)	199	200	200	199	214	257	255	255
Additional shipping weight (buffer tank)	(kg)	327	326	325	326	326	326	326	326
Refrigerant & Oil Charge									
Refrigerant Charge (Circuit 1/Circuit 2)	(kg)	10.9	12.7	12.7	15.4	17.2	20.9	21.8	22.7
Oil Charge (Circuit 1/Circuit 2)	(L)	6.6	6.6	6.6	13.4	13.4	13.4	13.4	13.4

(1) Eurovent Conditions (Evap. 12°C/7°C - Air. 35°C)

(2) amps for base unit without pump package, without freeze protection

(3) without pump package

General Data

Table 2 - CGAM - Standard Efficiency Compact - DUPLEX V units

Size		40	46	52	60	70	80	90	100
Eurovent Performances (1)									
Net capacity	(kW)	110.6	127.6	143.6	159.7	186.8	222.1	249.0	274.5
Total power input	(kW)	40.3	43.8	50.2	58.7	67.9	78.7	87.9	100.5
EER		2.75	2.92	2.86	2.72	2.75	2.82	2.83	2.73
Main power supply		400/3/50	400/3/50	400/3/50	400/3/50	400/3/50	400/3/50	400/3/50	400/3/50
Sound power level	(dBA)	90.9	90.8	91.1	91.8	93.6	95.6	94.7	93.7
System Data									
Refrigerant circuit	#	2	2	2	2	2	2	2	2
Capacity steps	%	25-50-75-100	21-43-71-100	25-50-75-100	25-50-75-100	21-43-71-100	25-50-75-100	22-44-72-100	25-50-75-100
Units Amps (2)									
Maximum amps	(A)	96.0	106.0	116.0	137.5	156.0	182.4	205.3	228.2
Start-up amps - standard unit	(A)	217.9	238.9	248.9	267.0	331.3	357.6	414.1	437.0
Start-up amps - with soft starter option	(A)	145.9	168.9	178.9	214.0	255.3	281.6	333.1	356.0
Short circuit unit capacity	(kA)	15	15	15	15	15	15	15	15
Min supply cable size	(mm ²)	95	95	95	95	150	150	185	185
Max supply cable size	(mm ²)	150	150	150	150	240	240	240	240
Compressor									
Number	#	4	4	4	4	4	4	4	4
Type		Scroll	Scroll	Scroll	Scroll	Scroll	Scroll	Scroll	Scroll
Model		CSHD125&CSHD125	CSHD125&CSHD161	CSHD161&CSHD161	CSHN184&CSHN184	CSHN184&CSHN250	CSHN250&CSHN250	CSHN250&CSHN315	CSHN315&CSHN315
Motor RPM	(rpm)	2900	2900	2900	2900	2900	2900	2900	2900
Power factor	#	0.85	0.85	0.85	0.85	0.85	0.85	0.85	0.85
Sump heater per circuit	(W)	160&160	160&160	160&160	160&160	160&160	160&160	160&160	160&160
Evaporator									
Quantity	#	1	1	1	1	1	1	1	1
Type		BPHE	BPHE	BPHE	BPHE	BPHE	BPHE	BPHE	BPHE
Water volume/storage (total)	(L)	9.1	10.5	14.3	15.6	18.9	24.0	26.5	32.4
Antifreeze heater	(W)	120	180				240		
Min. flow	(L/Sec)	2.6	3.0	3.4	3.7	4.4	5.2	5.8	6.5
Max. flow	(L/Sec)	7.7	8.9	10.1	11.2	13.1	15.6	17.5	19.4
Pump Package (Option Standard Head)									
Nb Pump Set	#	1	1	1	1	1	1	1	1
Motor RPM	(rpm)	2890	2890	2890	2890	2890	2890	2890	2890
Pump power (single / dual) - standard head	(kW)	3.0	4.0	4.0	4.0	5.5	5.5	5.5	5.5
Rated amps (single / dual) - standard head	(A)	6.1	7.59	7.59	7.59	10.6	10.6	10.6	10.6
Pump power (single / dual) - high head	(kW)	5.5	5.5	5.5	7.5	7.5	7.5	7.5	7.5
Rated amps (single / dual) - high head	(A)	10.6	10.6	10.6	13.8	13.8	13.8	13.8	13.8
Hydraulic Module Components									
Expansion tank volume	(L)	25	25	25	25	25	25	25	25
User volume expansion capacity	(L)	380	380	380	380	380	380	380	380

General Data

Size		40	46	52	60	70	80	90	100
Max. Water-side pressure without pump	(kPa)	1000	1000	1000	1000	1000	1000	1000	1000
Max. Water-side pressure with pump	(kPa)				400				
Antifreeze heater	(W)				910				
Water tank volume	(L)	515	515	515	515	515	515	515	515
Water tank antifreeze heater	(W)				800				
Condenser									
Type		Fin and Tube	Fin and Tube	Fin and Tube	Fin and Tube	Fin and Tube	Fin and Tube	Fin and Tube	Fin and Tube
Qty of coils	#	2	2	2	2	2	2	2	2
Fan									
Type		Propeller	Propeller	Propeller	Propeller	Propeller	Propeller	Propeller	Propeller
Quantity per circuit	#	2	2	2	2	2	3	3	3
Diameter	(mm)	732	732	732	732	732	732	732	732
Drive type		Direct	Direct	Direct	Direct	Direct	Direct	Direct	Direct
Airflow per fan	(m ³ /h)	13485	16114	16122	16129	17638	16088	17189	17195
Static pressure	(Pa)	0	0	0	0	0	0	0	0
Motor rpm	#	920	920	920	920	920	920	920	920
Unit Water Connection									
Chilled water	(mm)	65	65	65	80	80	80	80	80
Type (standard)		Grooved	Grooved	Grooved	Grooved	Grooved	Grooved	Grooved	Grooved
Dimensions									
Unit length with buffer tank	(mm)	3416	3416	3416	3416	3416	4330	4330	4330
Unit length without buffer tank	(mm)	2905	2905	2905	2905	2905	3819	3819	3819
Unit width	(mm)	2266	2266	2266	2266	2266	2266	2266	2266
Unit height	(mm)	2150	2150	2150	2150	2150	2150	2150	2150
Weight									
Operating weight(3)	(kg)	1503	1545	1571	1753	1794	2053	2185	2302
Shipping weight(3)	(kg)	1471	1512	1534	1715	1753	2007	2136	2248
Additional weight (single pump standard head)	(kg)	171	177	176	177	184	186	187	186
Additional weight (dual pump standard head)	(kg)	209	221	221	221	235	236	237	237
Additional weight (single pump high head)	(kg)	179	179	178	220	220	221	222	222
Additional weight (dual pump high head)	(kg)	226	226	225	317	316	318	318	319
Additional shipping weight (buffer tank)	(kg)	381	380	381	381	382	381	382	381
Refrigerant & Oil Charge									
Refrigerant Charge (Circuit 1/Circuit 2)	(kg)	10.9/10.9	13.2/13.2	13.2/13.2	16.3/16.3	18.1/18.1	20/20	21.8/21.8	23.6/23.6
Oil Charge (Circuit 1/Circuit 2)	(L)	6.6 / 6.6	6.6 / 6.6	6.6 / 6.6	13.4 / 13.4	13.4 / 13.4	13.4 / 13.4	13.4 / 13.4	13.4 / 13.4

(1) Eurovent Conditions (Evap. 12°C/7°C - Air. 35°C)

(2) amps for base unit without pump package, without freeze protection

(3) without pump package

General Data

Table 3 - CGAM - Standard Efficiency Compact - DUPLEX W units

Size		110	120	140	150	160	170
Eurovent Performances (1)							
Net capacity	(kW)	296.7	327.2	380.9	407.4	434.2	460.5
Total power input	(kW)	106.8	110.6	130.7	143.5	151.5	156.2
EER		2.78	2.96	2.91	2.84	2.86	2.95
Main power supply		400/3/50	400/3/50	400/3/50	400/3/50	400/3/50	400/3/50
Sound power level	(dBA)	95.2	93.4	94.7	93.0	94.1	94.6
System Data							
Refrigerant circuit	#	2	2	2	2	2	2
Capacity steps	%	23-45-73-100	25-50-75-100	14-29-46-64-82-100	17-33-50-67-83-100	16-31-47-63-81-100	15-29-47-65-82-100
Units Amps (2)							
Maximum amps	(A)	241.6	255.0	314.5	330.6	350.8	364.2
Start-up amps - standard unit	(A)	503.7	517.1	523.3	539.4	612.9	626.3
Start-up amps - with soft starter option	(A)	386.7	400.1	442.3	458.4	495.9	509.3
Short circuit unit capacity	(kA)	15	15	15	15	15	15
Min supply cable size	(mm ²)	150	185	240	240	240	240
Max supply cable size	(mm ²)	240	240	240	240	240	240
Compressor							
Number	#	4	4	6	6	6	6
Type		Scroll	Scroll	Scroll	Scroll	Scroll	Scroll
Model		CSHN315&CSHN374	CSHN374&CSHN374	CSHN250&CSHN315&CSHN315	CSHN315&CSHN315&CSHN315	CSHN315&CSHN315&CSHN374	CSHN315&CSHN374&CSHN374
Motor RPM	(rpm)	2900	2900	2900	2900	2900	2900
Power factor	#	0.85	0.85	0.85	0.85	0.85	0.85
Sump heater per circuit	(W)	160&160	160&160	160&160&160	160&160&160	160&160&160	160&160&160
Evaporator							
Quantity	#	1	1	1	1	1	1
Type		BPHE	BPHE	BPHE	BPHE	BPHE	BPHE
Water volume/storage (total)	(L)	32.4	34.1	40.8	46.7	46.7	46.7
Antifreeze heater	(W)	240			300		
Min. flow	(L/Sec)	7.0	7.7	9.0	9.6	10.2	10.8
Max. flow	(L/Sec)	21.0	23.2	27.1	28.8	30.7	32.5
Pump Package (Option Standard Head)							
Nb Pump Set	#	1	1	1	1	1	1
Motor RPM	(rpm)	2900	2900	2900	2900	2900	2900
Pump power (single / dual) - standard head	(kW)	7.5	7.5	11.0	11.0	11.0	11.0
Rated amps (single / dual) - standard head	(A)	13.8	13.8	19.6	19.6	19.6	19.6
Pump power (single / dual) - high head	(kW)	7.5	11.0	11.0	11.0	15.0	15.0
Rated amps (single / dual) - high head	(A)	13.8	19.6	19.6	19.6	26.5	26.5
Hydraulic Module Components							
Expansion tank volume	(L)	60	60	60	60	60	60
User volume expansion capacity	(L)	1750	1750	1750	1750	1750	1750
Max. Water-side pressure without pump	(kPa)	1000	1000	1000	1000	1000	1000
Max. Water-side pressure with pump	(kPa)	500	500	500	500	500	500
Antifreeze heater	(W)				300		

General Data

Size		110	120	140	150	160	170	
Pump package anti freeze heater	(W)	1150						
Water tank antifreeze heater	(W)	800		1200				
Water tank volume	(L)	592	592	762	762	762	762	
Condenser								
Type		Fin and Tube	Fin and Tube	Fin and Tube	Fin and Tube	Fin and Tube	Fin and Tube	
Qty of coils	#	4	4	4	4	4	4	
Fan								
Type		Propeller	Propeller	Propeller	Propeller	Propeller	Propeller	
Quantity per circuit	#	3	3	4	3	4	4	
Diameter	(mm)	732	732	732	732	732	732	
Drive type		Direct	Direct	Direct	Direct	Direct	Direct	
Airflow per fan	(m3/h)	18757	17770	17092	18618	17097	18325	
Static pressure	(Pa)	0	0	0	0	0	0	
Motor rpm	#	920	920	920	920	920	920	
Unit Water Connection								
Chilled water	(mm)	100	100	100	100	100	100	
Type (standard)		Grooved	Grooved	Grooved	Grooved	Grooved	Grooved	
Dimensions								
Unit length with buffer tank	(mm)	3647	3647	4230	4230	4230	5145	
Unit length without buffer tank	(mm)	3647	3647	4230	4230	4230	5145	
Unit width	(mm)	2273	2273	2273	2273	2273	2273	
Unit height	(mm)	2344	2344	2344	2344	2344	2344	
Weight								
Operating weight(3)	(kg)	2494	2615	3055	3082	3172	3426	
Shipping weight(3)	(kg)	2440	2560	2993	3014	3104	3359	
Additional weight (single pump standard head)	(kg)	314	314	354	355	355	376	
Additional weight (dual pump standard head)	(kg)	405	405	487	488	488	509	
Additional weight (single pump high head)	(kg)	310	356	355	355	368	389	
Additional weight (dual pump high head)	(kg)	407	489	488	489	515	536	
Additional shipping weight (buffer tank)	(kg)	203	203	251	251	252	252	
Refrigerant & Oil Charge								
Refrigerant Charge (Circuit 1/Circuit 2)	(kg)	27.2/27.2	33.6/33.6	41.7/41.7	40.8/40.8	42.6/42.6	51.7/51.7	
Oil Charge (Circuit 1/Circuit 2)	(L)	13.9 / 13.9	14.4 / 14.4	20.1 / 20.1	20.1 / 20.1	20.6 / 20.6	21.1 / 21.1	

(1) Eurovent Conditions (Evap. 12°C/7°C - Air. 35°C)

(2) amps for base unit without pump package, without freeze protection

(3) without pump package

General Data

Table 4 - CGAM - Standard Efficiency Super Quiet - SIMPLEX unit

Size		20	23	26	30	35	39	45	50
Eurovent Performances (1)									
Net capacity	(kW)	54.2	62.4	68.7	78.2	90.1	108.3	120.5	131.8
Total power input	(kW)	20.0	21.7	25.0	29.8	34.3	39.5	44.2	50.8
EER		2.70	2.87	2.74	2.62	2.62	2.74	2.72	2.60
Main power supply		400/3/50	400/3/50	400/3/50	400/3/50	400/3/50	400/3/50	400/3/50	400/3/50
Sound power level	(dBA)	82.5	82.4	82.4	83.0	84.7	86.7	86.0	85.2
System Data									
Refrigerant circuit	#	1	1	1	1	1	1	1	1
Capacity steps	%	50-100	43-100	50-100	50-100	43-100	50-100	44-100	50-100
Units Amps (2)									
Maximum amps	(A)	50.3	55.3	60.3	71.1	80.3	93.9	105.3	116.8
Start-up amps - standard unit	(A)	172.2	188.2	193.2	200.6	255.6	269.1	314.1	325.6
Start-up amps - with soft starter option	(A)	100.2	118.2	123.2	147.6	179.6	193.1	233.1	244.6
Short circuit unit capacity	(kA)	15	15	15	15	15	15	15	15
Min supply cable size	(mm ²)	50	50	50	50	95	95	95	95
Max supply cable size	(mm ²)	95	95	95	95	150	150	150	150
Compressor									
Number	#	2	2	2	2	2	2	2	2
Type		Scroll	Scroll	Scroll	Scroll	Scroll	Scroll	Scroll	Scroll
Model		CSHD125& CSHD125	CSHD125& CSHD161	CSHD161& CSHD161	CSHN184& CSHN184	CSHN184& CSHN250	CSHN250& CSHN250	CSHN250& CSHN315	CSHN315& CSHN315
Motor RPM	(rpm)	2900	2900	2900	2900	2900	2900	2900	2900
Power factor	#	0.85	0.85	0.85	0.85	0.85	0.85	0.85	0.85
Sump heater per circuit	(W)	90&90	90&90	90&90	160&160	160&160	160&160	160&160	160&160
Evaporator									
Quantity	#	1	1	1	1	1	1	1	1
Type		BPHE	BPHE	BPHE	BPHE	BPHE	BPHE	BPHE	BPHE
Water volume/storage (total)	(L)	4.0	4.0	4.0	6.7	6.7	10.6	10.6	13.3
Antifreeze heater	(W)			120			180		
Min. flow	(L/Sec)	1.3	1.5	1.6	1.8	2.1	2.5	2.8	3.1
Max. flow	(L/Sec)	3.8	4.4	4.8	5.5	6.3	7.6	8.5	9.3
Pump Package (Option Standard Head)									
Nb Pump Set	#	1	1	1	1	1	1	1	1
Motor RPM	(rpm)	2860	2860	2860	2860	2860	2890	2890	2890
Pump power (single / dual) - standard head	(kW)	1.5	1.5	1.5	1.5	1.5	3.0	3.0	3.0
Rated amps (single / dual) - standard head	(A)	3.25	3.25	3.25	3.25	3.25	6.1	6.1	6.1
Pump power (single / dual) - high head	(kW)	4.0	4.0	4.0	4.0	5.5	5.5	5.5	5.5
Rated amps (single / dual) - high head	(A)	7.59	7.59	7.59	7.59	10.6	10.6	10.6	10.6
Hydraulic Module Components									
Expansion tank volume	(L)	25	25	25	25	25	25	25	25
User volume expansion capacity	(L)	380	380	380	380	380	380	380	380

General Data

Size		20	23	26	30	35	39	45	50
Max. Water-side pressure without pump	(kPa)	1000	1000	1000	1000	1000	1000	1000	1000
Max. Water-side pressure with pump	(kPa)					400			
Antifreeze heater	(W)					180			
Pump package anti freeze heater	(W)					530			
Water tank antifreeze heater	(W)					860			
Water tank volume	(L)					500			
Condenser									
Type		Fin and Tube	Fin and Tube	Fin and Tube	Fin and Tube	Fin and Tube	Fin and Tube	Fin and Tube	Fin and Tube
Qty of coils	#	1	1	1	1	1	1	1	1
Fan									
Type		Propeller	Propeller	Propeller	Propeller	Propeller	Propeller	Propeller	Propeller
Quantity per circuit	#	2	2	2	2	2	3	3	3
Diameter	(mm)	762	762	762	762	762	762	762	762
Drive type		Direct	Direct	Direct	Direct	Direct	Direct	Direct	Direct
Airflow per fan	(m ³ /h)	9824	13101	13113	13130	15172	13068	14591	14601
Static pressure	(Pa)	0	0	0	0	0	0	0	0
Motor rpm	#	700	700	700	700	700	700	700	700
Unit Water Connection									
Chilled water	(mm)	50	50	50	65	65	65	65	65
Type (standard)		Grooved	Grooved	Grooved	Grooved	Grooved	Grooved	Grooved	Grooved
Dimensions									
Unit length with buffer tank	(mm)	3418	3418	3418	3418	3418	4332	4332	4332
Unit length without buffer tank	(mm)	2908	2908	2908	2908	2908	3822	3822	3822
Unit width	(mm)	1280	1280	1280	1280	1280	1280	1280	1280
Unit height	(mm)	2145	2145	2145	2145	2145	2145	2145	2145
Weight									
Operating weight (3)	(kg)	855	873	877	978	992	1147	1208	1267
Shipping weight (3)	(kg)	828	846	850	949	962	1113	1175	1231
Additional weight (single pump standard head)	(kg)	154	153	153	153	155	199	198	207
Additional weight (dual pump standard head)	(kg)	183	183	184	183	184	232	231	250
Additional weight (single pump high head)	(kg)	163	163	162	162	167	209	208	208
Additional weight (dual pump high head)	(kg)	199	200	200	199	214	257	255	255
Additional shipping weight (buffer tank)	(kg)	327	326	325	326	326	326	326	326
Refrigerant & Oil Charge									
Refrigerant Charge (Circuit 1/Circuit 2)	(kg)	10.9	12.7	12.7	15.4	17.2	20.0	21.8	21.8
Oil Charge (Circuit 1/Circuit 2)	(L)	6.6	6.6	6.6	13.4	13.4	13.4	13.4	13.4

(1) Eurovent Conditions (Evap. 12°C/7°C - Air. 35°C)
 (2) amps for base unit without pump package, without freeze protection
 (3) without pump package

General Data

Table 5 - CGAM - Standard Efficiency Super Quiet - DUPLEX V units

Size		40	46	52	60	70	80	90	100
Eurovent Performances (1)									
Net capacity	(kW)	107.9	125.9	141.2	156.5	184.0	218.3	245.6	270.0
Total power input	(kW)	39.6	43.1	49.8	58.9	68.3	78.5	87.6	100.6
EER		2.73	2.92	2.83	2.66	2.70	2.78	2.80	2.68
Main power supply		400/3/50	400/3/50	400/3/50	400/3/50	400/3/50	400/3/50	400/3/50	400/3/50
Sound power level	(dBA)	85.4	85.3	85.5	86.0	87.6	89.5	88.8	88.0
System Data									
Refrigerant circuit	#	2	2	2	2	2	2	2	2
Capacity steps	%	25-50-75-100	21-43-71-100	25-50-75-100	25-50-75-100	21-43-71-100	25-50-75-100	22-44-72-100	25-50-75-100
Units Amps (2)									
Maximum amps	(A)	99.6	109.6	119.6	141.1	159.6	186.8	209.7	232.6
Start-up amps - standard unit	(A)	221.5	242.5	252.5	270.6	334.9	362.0	418.5	441.4
Start-up amps - with soft starter option	(A)	149.5	172.5	182.5	217.6	258.9	286.0	337.5	360.4
Short circuit unit capacity	(kA)	15	15	15	15	15	15	15	15
Min supply cable size	(mm ²)	95	95	95	95	150	150	185	185
Max supply cable size	(mm ²)	150	150	150	150	240	240	240	240
Compressor									
Number	#	4	4	4	4	4	4	4	4
Type		Scroll	Scroll	Scroll	Scroll	Scroll	Scroll	Scroll	Scroll
Model		CSHD125&CSHD125	CSHD125&CSHD161	CSHD161&CSHD161	CSHN184&CSHN184	CSHN184&CSHN250	CSHN250&CSHN250	CSHN250&CSHN315	CSHN315&CSHN315
Motor RPM	(rpm)	2900	2900	2900	2900	2900	2900	2900	2900
Power factor	#	0.85	0.85	0.85	0.85	0.85	0.85	0.85	0.85
Sump heater per circuit	(W)	160&160	160&160	160&160	160&160	160&160	160&160	160&160	160&160
Evaporator									
Quantity	#	1	1	1	1	1	1	1	1
Type		BPHE	BPHE	BPHE	BPHE	BPHE	BPHE	BPHE	BPHE
Water volume/storage (total)	(L)	9.1	10.5	14.3	15.6	18.9	24.0	26.5	32.4
Antifreeze heater	(W)	120	180				240		
Min. flow	(L/Sec)	2.5	2.9	3.3	3.7	4.3	5.1	5.8	6.3
Max. flow	(L/Sec)	7.5	8.8	9.9	11.0	12.9	15.4	17.3	19.0
Pump Package (Option Standard Head)									
Nb Pump Set	#	1	1	1	1	1	1	1	1
Motor RPM	(rpm)	2890	2890	2890	2890	2890	2890	2890	2890
Pump power (single / dual) - standard head	(kW)	3.0	4.0	4.0	4.0	5.5	5.5	5.5	5.5
Rated amps (single / dual) - standard head	(A)	6.1	7.59	7.59	7.59	10.6	10.6	10.6	10.6
Pump power (single / dual) - high head	(kW)	5.5	5.5	5.5	7.5	7.5	7.5	7.5	7.5
Rated amps (single / dual) - high head	(A)	10.6	10.6	10.6	13.8	13.8	13.8	13.8	13.8
Hydraulic Module Components									
Expansion tank volume	(L)	25	25	25	25	25	25	25	25
User volume expansion capacity	(L)	380	380	380	380	380	380	380	380

General Data

Size		40	46	52	60	70	80	90	100
Max. Water-side pressure without pump	(kPa)	1000	1000	1000	1000	1000	1000	1000	1000
Max. Water-side pressure with pump	(kPa)				400				
Antifreeze heater	(W)				120				
Pump package anti freeze heater	(W)				910				
Water tank antifreeze heater	(W)				800				
Water tank volume	(L)	515	515	515	515	515	515	515	515
Condenser									
Type		Fin and Tube	Fin and Tube	Fin and Tube	Fin and Tube	Fin and Tube	Fin and Tube	Fin and Tube	Fin and Tube
Qty of coils	#	2	2	2	2	2	2	2	2
Fan									
Type		Propeller	Propeller	Propeller	Propeller	Propeller	Propeller	Propeller	Propeller
Quantity per circuit	#	2	2	2	2	2	3	3	3
Diameter	(mm)	762	762	762	762	762	762	762	762
Drive type		Direct	Direct	Direct	Direct	Direct	Direct	Direct	Direct
Airflow per fan	(m3/h)	9824	13102	13115	13130	15173	13069	14592	14603
Static pressure	(Pa)	0	0	0	0	0	0	0	0
Motor rpm	#	700	700	700	700	700	700	700	700
Unit Water Connection									
Chilled water	(mm)	65	65	65	80	80	80	80	80
Type (standard)		Grooved	Grooved	Grooved	Grooved	Grooved	Grooved	Grooved	Grooved
Dimensions									
Unit length with buffer tank	(mm)	3416	3416	3416	3416	3416	4330	4330	4330
Unit length without buffer tank	(mm)	2905	2905	2905	2905	2905	3819	3819	3819
Unit width	(mm)	2266	2266	2266	2266	2266	2266	2266	2266
Unit height	(mm)	2150	2150	2150	2150	2150	2150	2150	2150
Weight									
Operating weight(3)	(kg)	1503	1545	1571	1753	1794	2053	2185	2302
Shipping weight(3)	(kg)	1471	1512	1534	1715	1753	2007	2136	2248
Additional weight (single pump standard head)	(kg)	171	177	176	177	184	186	186	186
Additional weight (dual pump standard head)	(kg)	209	221	221	221	235	236	237	237
Additional weight (single pump high head)	(kg)	179	179	178	220	220	222	223	222
Additional weight (dual pump high head)	(kg)	226	226	225	317	316	319	318	319
Additional shipping weight (buffer tank)	(kg)	381	380	381	381	382	380	382	381
Refrigerant & Oil Charge									
Refrigerant Charge (Circuit 1/Circuit 2)	(kg)	10.9/10.9	13.2/13.2	13.2/13.2	16.3/16.3	18.1/18.1	20/20	20.9/20.9	22.7/22.7
Oil Charge (Circuit 1/Circuit 2)	(L)	6.6 / 6.6	6.6 / 6.6	6.6 / 6.6	13.4 / 13.4	13.4 / 13.4	13.4 / 13.4	13.4 / 13.4	13.4 / 13.4

(1) Eurovent Conditions (Evap. 12°C/7°C - Air. 35°C)

(2) amps for base unit without pump package, without freeze protection

(3) without pump package

General Data

Table 6 - CGAM - Standard Efficiency Super Quiet - DUPLEX W units

Size		110	120	140	150	160	170
Eurovent Performances (1)							
Net capacity	(kW)	291.7	321.6	374.3	399.8	424.5	453.8
Total power input	(kW)	107.5	112.2	132.3	145.8	154.5	158.1
EER		2.71	2.87	2.83	2.74	2.75	2.87
Main power supply		400/3/50	400/3/50	400/3/50	400/3/50	400/3/50	400/3/50
Sound power level	(dBA)	89.7	88.1	88.7	87.2	88.5	89.1
System Data							
Refrigerant circuit	#	2	2	2	2	2	2
Capacity steps	%	23-45-73-100	25-50-75-100	14-29-46-64-82-100	17-33-50-67-83-100	16-31-47-63-81-100	15-29-47-65-82-100
Units Amps (2)							
Maximum amps	(A)	246.0	259.4	320.7	335.0	357.0	370.4
Start-up amps - standard unit	(A)	508.1	521.5	529.5	543.8	619.1	632.5
Start-up amps - with soft starter option	(A)	391.1	404.5	448.5	462.8	502.1	515.5
Short circuit unit capacity	(kA)	15	15	15	15	15	15
Min supply cable size	(mm ²)	150	185	240	240	240	240
Max supply cable size	(mm ²)	240	240	240	240	240	240
Compressor							
Number	#	4	4	6	6	6	6
Type		Scroll	Scroll	Scroll	Scroll	Scroll	Scroll
Model		CSHN315& CSHN374	CSHN374& CSHN374	CSHN250& CSHN315& CSHN315	CSHN315& CSHN315& CSHN315	CSHN315& CSHN315& CSHN374	CSHN315& CSHN374& CSHN374
Motor RPM	(rpm)	2900	2900	2900	2900	2900	2900
Power factor	#	0.85	0.85	0.85	0.85	0.85	0.85
Sump heater per circuit	(W)	160&160	160&160	160& 160&160	160& 160&160	160& 160&160	160& 160&160
Evaporator							
Quantity	#	1	1	1	1	1	1
Type		BPHE	BPHE	BPHE	BPHE	BPHE	BPHE
Water volume/storage (total)	(L)	32.4	34.1	40.8	46.7	46.7	46.7
Antifreeze heater	(W)	400	500	500	500	500	500
Min. flow	(L/Sec)	6.9	7.6	8.9	9.4	10.0	10.7
Max. flow	(L/Sec)	20.6	22.8	26.6	28.2	30.0	32.0
Pump Package (Option Standard Head)							
Nb Pump Set	#	1	1	1	1	1	1
Motor RPM	(rpm)	2900	2900	2900	2900	2900	2900
Pump power (single / dual) - standard head	(kW)	7.5	7.5	11.0	11.0	11.0	11.0
Rated amps (single / dual) - standard head	(A)	13.8	13.8	19.6	19.6	19.6	19.6
Pump power (single / dual) - high head	(kW)	7.5	11.0	11.0	11.0	15.0	15.0
Rated amps (single / dual) - high head	(A)	13.8	19.6	19.6	19.6	26.5	26.5
Hydraulic Module Components							
Expansion tank volume	(L)	60	60	60	60	60	60
User volume expansion capacity	(L)	1750	1750	1750	1750	1750	1750
Max. Water-side pressure without pump	(kPa)	1000	1000	1000	1000	1000	1000

General Data

Size		110	120	140	150	160	170
Max. Water-side pressure with pump	(kPa)	500	500	500	500	500	500
Antifreeze heater	(W)	240			240		300
Pump package anti freeze heater	(W)				1150		
Water tank antifreeze heater	(W)	1200	1200	1200	1200	1200	1200
Water tank volume	(L)	592	592	762	762	762	762
Condenser							
Type		Fin and Tube	Fin and Tube	Fin and Tube	Fin and Tube	Fin and Tube	Fin and Tube
Qty of coils	#	4	4	4	4	4	4
Fan							
Type		Propeller	Propeller	Propeller	Propeller	Propeller	Propeller
Quantity per circuit	#	3	3	4	3	4	4
Diameter	(mm)	762	762	762	762	762	762
Drive type		Direct	Direct	Direct	Direct	Direct	Direct
Airflow per fan	(m3/h)	15779	14718	13658	15924	13674	15522
Static pressure	(Pa)	0	0	0	0	0	0
Motor rpm	#	700	700	700	700	700	700
Unit Water Connection							
Chilled water	(mm)	100	100	100	100	100	100
Type (standard)		Grooved	Grooved	Grooved	Grooved	Grooved	Grooved
Dimensions							
Unit length with buffer tank	(mm)	3647	3647	4230	4230	4230	5145
Unit length without buffer tank	(mm)	3647	3647	4230	4230	4230	5145
Unit width	(mm)	2273	2273	2273	2273	2273	2273
Unit height	(mm)	2344	2344	2344	2344	2344	2344
Weight							
Operating weight (3)	(kg)	2494	2615	3055	3082	3172	3426
Shipping weight (3)	(kg)	2440	2560	2993	3014	3104	3359
Additional weight (single pump standard head)	(kg)	314	314	354	355	355	376
Additional weight (dual pump standard head)	(kg)	405	405	487	488	488	509
Additional weight (single pump high head)	(kg)	310	356	355	355	368	389
Additional weight (dual pump high head)	(kg)	407	489	488	489	515	536
Additional shipping weight (buffer tank)	(kg)	203	203	251	251	252	252
Refrigerant & Oil Charge							
Refrigerant Charge (Circuit 1/Circuit 2)	(kg)	26.3/26.3	33.6/33.6	40.8/40.8	40.8/40.8	42.6/42.6	49.9/49.9
Oil Charge (Circuit 1/Circuit 2)	(L)	13.9 / 13.9	14.4 / 14.4	20.1 / 20.1	20.1 / 20.1	20.6 / 20.6	21.1 / 21.1

(1) Eurovent Conditions (Evap. 12°C/7°C - Air. 35°C)
 (2) amps for base unit without pump package, without freeze protection
 (3) without pump package

General Data

Table 7 - CGAM - Standard Efficiency Comprehensive acoustic package - SIMPLEX units

Size		20	23	26	30	35	39
Eurovent Performances (1)							
Net capacity	(kW)	53.4	60.6	68.5	75.2	91.8	106.2
Total power input	(kW)	19.4	21.7	25.6	29.1	34.7	39.2
EER		2.75	2.80	2.68	2.59	2.65	2.71
Main power supply		400/3/50	400/3/50	400/3/50	400/3/50	400/3/50	400/3/50
Sound power level	(dBA)	76.4	76.5	76.6	77.9	82.1	83.6
System Data							
Refrigerant circuit	#	1	1	1	1	1	1
Capacity steps	%	50-100	43-100	50-100	50-100	43-100	50-100
Units Amps (2)							
Maximum amps	(A)	44.4	49.4	54.4	65.2	75.8	85.0
Start-up amps - standard unit	(A)	166.3	182.3	187.3	194.7	251.0	260.3
Start-up amps - with soft starter option	(A)	94.3	112.3	117.3	141.7	175.0	184.3
Short circuit unit capacity	(kA)	15	15	15	15	15	15
Min supply cable size	(mm ²)	50	50	50	50	95	95
Max supply cable size	(mm ²)	95	95	95	95	150	150
Compressor							
Number	#	2	2	2	2	2	2
Type		Scroll	Scroll	Scroll	Scroll	Scroll	Scroll
Model		CSHD125& CSHD125	CSHD125& CSHD161	CSHD161& CSHD161	CSHN184& CSHN184	CSHN184& CSHN250	CSHN250& CSHN250
Motor RPM	(rpm)	2900	2900	2900	2900	2900	2900
Power factor	#	0.85	0.85	0.85	0.85	0.85	0.85
Sump heater per circuit	(W)	90&90	90&90	90&90	160&160	160&160	160&160
Evaporator							
Quantity	#	1	1	1	1	1	1
Type		BPHE	BPHE	BPHE	BPHE	BPHE	BPHE
Water volume/storage (total)	(L)	4.0	4.0	5.3	5.3	10.6	10.6
Antifreeze heater	(W)		120			180	
Min. flow	(L/Sec)	1.2	1.4	1.6	1.8	2.1	2.5
Max. flow	(L/Sec)	3.7	4.2	4.8	5.3	6.4	7.5
Pump Package (Option Standard Head)							
Nb Pump Set	#	1	1	1	1	1	1
Motor RPM	(rpm)	2860	2860	2860	2860	2860	2890
Pump power (single / dual) - standard head	(kW)	1.5	1.5	1.5	1.5	1.5	3.0
Rated amps (single / dual) - standard head	(A)	3.25	3.25	3.25	3.25	3.25	6.1
Pump power (single / dual) - high head	(kW)	4.0	4.0	4.0	4.0	5.5	5.5
Rated amps (single / dual) - high head	(A)	7.59	7.59	7.59	7.59	10.6	10.6
Hydraulic Module Components							
Expansion tank volume	(L)	25	25	25	25	25	25
User volume expansion capacity	(L)	380	380	380	380	380	380
Max. Water-side pressure without pump	(kPa)	1000	1000	1000	1000	1000	1000
Max. Water-side pressure with pump	(kPa)				400		
Antifreeze heater	(W)				180		
Pump package anti freeze heater	(W)				530		

General Data

Size		20	23	26	30	35	39
Water tank antifreeze heater	(W)				860		
Water tank volume	(L)				500		
Condenser							
Type		Fin and Tube	Fin and Tube	Fin and Tube	Fin and Tube	Fin and Tube	Fin and Tube
Qty of coils	#	1	1	1	1	1	1
Fan							
Type		Propeller	Propeller	Propeller	Propeller	Propeller	Propeller
Quantity per circuit	#	2	2	2	2	3	3
Diameter	(mm)	757	757	757	757	757	757
Drive type		Direct	Direct	Direct	Direct	Direct	Direct
Airflow per fan	(m ³ /h)	8559	9520	9525	10085	8929	9917
Static pressure	(Pa)	0	0	0	0	0	0
Motor rpm	#	700	700	700	700	700	700
Unit Water Connection							
Chilled water	(mm)	50	50	50	65	65	65
Type (standard)		Grooved	Grooved	Grooved	Grooved	Grooved	Grooved
Dimensions							
Unit length with buffer tank	(mm)	3418	3418	3418	3418	4332	4332
Unit length without buffer tank	(mm)	2908	2908	2908	2908	3822	3822
Unit width	(mm)	1280	1280	1280	1280	1280	1280
Unit height	(mm)	2145	2145	2145	2145	2145	2145
Weight							
Operating weight (3)	(kg)	889	907	916	1031	1179	1206
Shipping weight (3)	(kg)	862	880	888	1003	1146	1173
Additional weight (single pump standard head)	(kg)	154	154	154	154	195	198
Additional weight (dual pump standard head)	(kg)	184	183	184	183	225	231
Additional weight (single pump high head)	(kg)	163	162	163	163	207	208
Additional weight (dual pump high head)	(kg)	200	199	200	200	255	255
Additional shipping weight (buffer tank)	(kg)	326	326	326	326	326	326
Refrigerant & Oil Charge							
Refrigerant Charge (Circuit 1/Circuit 2)	(kg)	10.9	12.7	12.7	16.3	17.2	20.0
Oil Charge (Circuit 1/Circuit 2)	(L)	6.6	6.6	6.6	13.4	13.4	13.4

(1) Eurovent Conditions (Evap. 12°C/7°C - Air. 35°C)

(2) amps for base unit without pump package, without freeze protection

(3) without pump package

General Data

Table 8 - CGAM - Standard Efficiency Comprehensive acoustic package - DUPLEX V units

Size		40	46	52	60	70	80
Eurovent Performances (1)							
Net capacity	(kW)	106.4	122.3	136.1	154.0	181.3	214.0
Total power input	(kW)	38.3	42.8	50.2	57.7	68.1	77.4
EER		2.78	2.86	2.71	2.67	2.66	2.77
Main power supply		400/3/50	400/3/50	400/3/50	400/3/50	400/3/50	400/3/50
Sound power level	(dBA)	79.4	79.5	79.6	80.9	84.6	86.4
System Data							
Refrigerant circuit	#	2	2	2	2	2	2
Capacity steps	%	25-50-75-100	21-43-71-100	25-50-75-100	25-50-75-100	21-43-71-100	25-50-75-100
Units Amps (2)							
Maximum amps	(A)	87.8	97.8	107.8	129.3	150.5	169.1
Start-up amps - standard unit	(A)	209.7	230.7	240.7	258.8	325.8	344.3
Start-up amps - with soft starter option	(A)	137.7	160.7	170.7	205.8	249.8	268.3
Short circuit unit capacity	(kA)	15	15	15	15	15	15
Min supply cable size	(mm ²)	95	95	95	95	95	95
Max supply cable size	(mm ²)	150	150	150	150	150	150
Compressor							
Number	#	4	4	4	4	4	4
Type		Scroll	Scroll	Scroll	Scroll	Scroll	Scroll
Model		CSHD125& CSHD125	CSHD125& CSHD161	CSHD161& CSHD161	CSHN184& CSHN184	CSHN184& CSHN250	CSHN250& CSHN250
Motor RPM	(rpm)	2900	2900	2900	2900	2900	2900
Power factor	#	0.85	0.85	0.85	0.85	0.85	0.85
Sump heater per circuit	(W)	160&160	160&160	160&160	160&160	160&160	160&160
Evaporator							
Quantity	#	1	1	1	1	1	1
Type		BPHE	BPHE	BPHE	BPHE	BPHE	BPHE
Water volume/storage (total)	(L)	9.1	10.5	14.3	15.6	18.9	24.0
Antifreeze heater	(W)	120		180			240
Min. flow	(L/Sec)	2.5	2.8	3.2	3.6	4.2	5.0
Max. flow	(L/Sec)	7.4	8.5	9.5	10.8	12.7	15.0
Pump Package (Option Standard Head)							
Nb Pump Set	#	1	1	1	1	1	1
Motor RPM	(rpm)	2890	2890	2890	2890	2890	2890
Pump power (single / dual) - standard head	(kW)	3.0	4.0	4.0	4.0	5.5	5.5
Rated amps (single / dual) - standard head	(A)	6.1	7.59	7.59	7.59	10.6	10.6
Pump power (single / dual) - high head	(kW)	5.5	5.5	5.5	7.5	7.5	7.5
Rated amps (single / dual) - high head	(A)	10.6	10.6	10.6	13.8	13.8	13.8
Hydraulic Module Components							
Expansion tank volume	(L)	25	25	25	25	25	25
User volume expansion capacity	(L)	380	380	380	380	380	380
Max. Water-side pressure without pump	(kPa)	1000	1000	1000	1000	1000	1000
Max. Water-side pressure with pump	(kPa)				400		
Antifreeze heater	(W)				120		
Pump package anti freeze heater	(W)				910		

General Data

Size		40	46	52	60	70	80
Water tank antifreeze heater	(W)				800		
Water tank volume	(L)	515	515	515	515	515	515
Condenser							
Type		Fin and Tube	Fin and Tube	Fin and Tube	Fin and Tube	Fin and Tube	Fin and Tube
Qty of coils	#	2	2	2	2	2	2
Fan							
Type		Propeller	Propeller	Propeller	Propeller	Propeller	Propeller
Quantity per circuit	#	2	2	2	2	3	3
Diameter	(mm)	757	757	757	757	757	757
Drive type		Direct	Direct	Direct	Direct	Direct	Direct
Airflow per fan	(m3/h)	8559	9520	9525	10086	8929	9917
Static pressure	(Pa)	0	0	0	0	0	0
Motor rpm	#	700	700	700	700	700	700
Unit Water Connection							
Chilled water	(mm)	65	65	65	80	80	80
Type (standard)		Grooved	Grooved	Grooved	Grooved	Grooved	Grooved
Dimensions							
Unit length with buffer tank	(mm)	3416	3416	3416	3416	4330	4330
Unit length without buffer tank	(mm)	2905	2905	2905	2905	3819	3819
Unit width	(mm)	2266	2266	2266	2266	2266	2266
Unit height	(mm)	2150	2150	2150	2150	2150	2150
Weight							
Operating weight (3)	(kg)	1571	1613	1638	1870	2095	2170
Shipping weight (3)	(kg)	1539	1580	1601	1832	2054	2124
Additional weight (single pump standard head)	(kg)	171	177	178	178	186	186
Additional weight (dual pump standard head)	(kg)	209	221	221	222	236	237
Additional weight (single pump high head)	(kg)	179	179	179	221	222	222
Additional weight (dual pump high head)	(kg)	225	226	226	317	318	318
Additional shipping weight (buffer tank)	(kg)	382	380	381	382	381	381
Refrigerant & Oil Charge							
Refrigerant Charge (Circuit 1/Circuit 2)	(kg)	10.9/10.9	13.2/13.2	13.2/13.2	17.2/17.2	17.2/17.2	20.9/20.9
Oil Charge (Circuit 1/Circuit 2)	(L)	6.6 / 6.6	6.6 / 6.6	6.6 / 6.6	13.4 / 13.4	13.4 / 13.4	13.4 / 13.4

(1) Eurovent Conditions (Evap. 12°C/7°C - Air. 35°C)

(2) amps for base unit without pump package, without freeze protection

(3) without pump package

General Data

Table 9 - Standard Efficiency Comprehensive acoustic package - DUPLEX W units

Size		90	100	110	120	140	150	160
Eurovent Performances (1)								
Net capacity	(kW)	237.5	264.0	289.7	319.3	371.8	394.8	422.4
Total power input	(kW)	88.1	99.3	105.8	110.4	132.4	145.6	150.8
EER		2.70	2.66	2.74	2.89	2.81	2.71	2.80
Main power supply		400/3/50	400/3/50	400/3/50	400/3/50	400/3/50	400/3/50	400/3/50
Sound power level	(dBA)	85.7	84.1	85.5	84.3	85.3	83.3	84.6
System Data								
Refrigerant circuit	#	2	2	2	2	2	2	2
Capacity steps	%	22-44-72-100	25-50-75-100	23-45-73-100	25-50-75-100	14-29-46-64-82-100	17-33-50-67-83-100	16-31-47-63-81-100
Units Amps (2)								
Maximum amps	(A)	192.0	214.9	231.0	244.4	297.1	320.0	336.1
Start-up amps - standard unit	(A)	400.8	423.7	493.1	506.5	505.9	528.8	598.2
Start-up amps - with soft starter option	(A)	319.8	342.7	376.1	389.5	424.9	447.8	481.2
Short circuit unit capacity	(kA)	15	15	15	15	15	15	15
Min supply cable size	(mm ²)	150	150	185	185	150	185	240
Max supply cable size	(mm ²)	240	240	240	240	240	240	240
Compressor								
Number	#	4	4	4	4	6	6	6
Type		Scroll	Scroll	Scroll	Scroll	Scroll	Scroll	Scroll
Model		CSHN250&CSHN315	CSHN315&CSHN315	CSHN315&CSHN374	CSHN374&CSHN374	CSHN250&CSHN315&CSHN315	CSHN315&CSHN315&CSHN315	CSHN315&CSHN315&CSHN374
Motor RPM	(rpm)	2900	2900	2900	2900	2900	2900	2900
Power factor	#	0.85	0.85	0.85	0.85	0.85	0.85	0.85
Sump heater per circuit	(W)	160&160	160&160	160&160	160&160	160&160&160	160&160&160	160&160&160
Evaporator								
Quantity	#	1	1	1	1	1	1	1
Type		BPHE	BPHE	BPHE	BPHE	BPHE	BPHE	BPHE
Water volume/storage (total)	(L)	26.5	32.4	32.4	34.1	39.2	46.7	46.7
Antifreeze heater	(W)		240			300		
Min. flow	(L/Sec)	5.6	6.2	6.8	7.5	8.7	9.3	9.9
Max. flow	(L/Sec)	16.7	18.6	20.4	22.6	26.2	27.8	29.8
Pump Package (Option Standard Head)								
Nb Pump Set	#	1	1	1	1	1	1	1
Motor RPM	(rpm)	2890	2890	2900	2900	2900	2900	2900
Pump power (single / dual) - standard head	(kW)	5.5	5.5	7.5	7.5	11.0	11.0	11.0
Rated amps (single / dual) - standard head	(A)	10.6	10.6	13.8	13.8	19.6	19.6	19.6
Pump power (single / dual) - high head	(kW)	7.5	7.5	7.5	11.0	11.0	11.0	15.0
Rated amps (single / dual) - high head	(A)	13.8	13.8	13.8	19.6	19.6	19.6	26.5
Hydraulic Module Components								
Expansion tank volume	(L)	60	60	60	60	60	60	60
User volume expansion capacity	(L)	1750	1750	1750	1750	1750	1750	1750

General Data

Size		90	100	110	120	140	150	160
Max. Water-side pressure without pump	(kPa)	1000	1000	1000	1000	1000	1000	1000
Max. Water-side pressure with pump	(kPa)	500	500	500	500	500	500	500
Antifreeze heater	(W)		240				300	
Pump package anti freeze heater	(W)				1150			
Water tank antifreeze heater	(W)	800	1200	1200	1200	1200	1200	1200
Water tank volume	(L)	592	592	592	592	762	762	762
Condenser								
Type		Fin and Tube	Fin and Tube	Fin and Tube	Fin and Tube	Fin and Tube	Fin and Tube	Fin and Tube
Qty of coils	#	4	4	4	4	4	4	4
Fan								
Type		Propeller	Propeller	Propeller	Propeller	Propeller	Propeller	Propeller
Quantity per circuit	#	3	3	4	4	4	4	5
Diameter	(mm)	757	757	757	757	757	757	757
Drive type		Direct	Direct	Direct	Direct	Direct	Direct	Direct
Airflow per fan	(m ³ /h)	10292	10596	10052	9633	10168	10170	9636
Static pressure	(Pa)	0	0	0	0	0	0	0
Motor rpm	#	700	700	700	700	700	700	700
Unit Water Connection								
Chilled water	(mm)	100	100	100	100	100	100	100
Type (standard)		Grooved	Grooved	Grooved	Grooved	Grooved	Grooved	Grooved
Dimensions								
Unit length with buffer tank	(mm)	3647	4230	4230	4230	5145	5145	5145
Unit length without buffer tank	(mm)	3647	4230	4230	4230	5145	5145	5145
Unit width	(mm)	2273	2273	2273	2273	2273	2273	2273
Unit height	(mm)	2344	2344	2344	2344	2344	2344	2344
Weight								
Operating weight(3)	(kg)	2491	2683	2773	2916	3454	3580	3670
Shipping weight(3)	(kg)	2442	2629	2719	2861	3394	3513	3602
Additional weight (single pump standard head)	(kg)	273	274	314	314	377	376	377
Additional weight (dual pump standard head)	(kg)	324	325	405	405	511	509	509
Additional weight (single pump high head)	(kg)	310	310	310	355	377	376	390
Additional weight (dual pump high head)	(kg)	406	407	407	489	511	510	537
Additional shipping weight (buffer tank)	(kg)	203	203	202	203	252	251	251
Refrigerant & Oil Charge								
Refrigerant Charge (Circuit 1/Circuit 2)	(kg)	25.4/25.4	28.1/28.1	29/29	38.1/38.1	47.2/47.2	47.2/47.2	47.2/47.2
Oil Charge (Circuit 1/Circuit 2)	(L)	13.4 / 13.4	13.4 / 13.4	13.9 / 13.9	14.4 / 14.4	20.1 / 20.1	20.1 / 20.1	20.6 / 20.6

(1) Eurovent Conditions (Evap. 12°C/7°C - Air. 35°C)

(2) amps for base unit without pump package, without freeze protection

(3) without pump package

General Data

Table 10 - CGAM - High Efficiency Compact - SIMPLEX units

Size		20	23	26	30	35
Eurovent Performances (1)						
Net capacity	(kW)	58.3	63.7	73.8	84.0	97.1
Total power input	(kW)	18.3	20.5	23.8	26.9	31.7
EER		3.18	3.11	3.10	3.13	3.07
Main power supply		400/3/50	400/3/50	400/3/50	400/3/50	400/3/50
Sound power level	(dBA)	84.8	85.0	85.2	87.7	90.0
System Data						
Refrigerant circuit	#	1	1	1	1	1
Capacity steps	%	50-100	43-100	50-100	50-100	43-100
Units Amps (2)						
Maximum amps	(A)	45.9	50.9	55.9	66.7	78.0
Start-up amps - standard unit	(A)	167.8	183.8	188.8	196.2	253.3
Start-up amps - with soft starter option	(A)	95.8	113.8	118.8	143.2	177.3
Short circuit unit capacity	(kA)	15	15	15	15	15
Min supply cable size	(mm ²)	50	50	50	50	50
Max supply cable size	(mm ²)	95	95	95	95	95
Compressor						
Number	#	2	2	2	2	2
Type		Scroll	Scroll	Scroll	Scroll	Scroll
Model		CSHD125&CSHD125	CSHD125&CSHD161	CSHD161&CSHD161	CSHN184&CSHN184	CSHN184&CSHN250
Motor RPM	(rpm)	2900	2900	2900	2900	2900
Power factor	#	0.85	0.85	0.85	0.85	0.85
Sump heater per circuit	(W)	90&90	90&90	90&90	160&160	160&160
Evaporator						
Quantity	#	1	1	1	1	1
Type		BPHE	BPHE	BPHE	BPHE	BPHE
Water volume/storage (total)	(L)	5.3	5.3	8.2	8.2	12.1
Antifreeze heater	(W)		120			180
Min. flow	(L/Sec)	1.4	1.5	1.7	2.0	2.3
Max. flow	(L/Sec)	4.1	4.6	5.2	5.9	6.9
Pump Package (Option Standard Head)						
Nb Pump Set	#	1	1	1	1	1
Motor RPM	(rpm)	2860	2860	2860	2860	2860
Pump power (single / dual) - standard head	(kW)	1.5	1.5	1.5	1.5	1.5
Rated amps (single / dual) - standard head	(A)	3.25	3.25	3.25	3.25	3.25
Pump power (single / dual) - high head	(kW)	4.0	4.0	4.0	4.0	5.5
Rated amps (single / dual) - high head	(A)	7.59	7.59	7.59	7.59	10.6
Hydraulic Module Components						
Expansion tank volume	(L)	25	25	25	25	25
User volume expansion capacity	(L)	380	380	380	380	380
Max. Water-side pressure without pump	(kPa)	1000	1000	1000	1000	1000
Max. Water-side pressure with pump	(kPa)			400		
Antifreeze heater	(W)			180		
Pump package anti freeze heater	(W)			530		

General Data

Size		20	23	26	30	35
Water tank antifreeze heater	(W)			860		
Water tank volume	(L)			500		
Condenser						
Type		Fin and Tube	Fin and Tube	Fin and Tube	Fin and Tube	Fin and Tube
Qty of coils	#	1	1	1	1	1
Fan						
Type		Propeller	Propeller	Propeller	Propeller	Propeller
Quantity per circuit	#	2	2	2	3	3
Diameter	(mm)	757	757	757	757	757
Drive type		Direct	Direct	Direct	Direct	Direct
Airflow per fan	(m3/h)	13341	13344	13347	13129	13133
Static pressure	(Pa)	0	0	0	0	0
Motor rpm	#	920	920	920	920	920
Unit Water Connection						
Chilled water	(mm)	50	50	50	65	65
Type (standard)		Grooved	Grooved	Grooved	Grooved	Grooved
Dimensions						
Unit length with buffer tank	(mm)	3418	3418	3418	4332	4332
Unit length without buffer tank	(mm)	2908	2908	2908	3822	3822
Unit width	(mm)	1280	1280	1280	1280	1280
Unit height	(mm)	2145	2145	2145	2145	2145
Weight						
Operating weight (3)	(kg)	888	887	902	1105	1161
Shipping weight (3)	(kg)	860	860	873	1074	1128
Additional weight (single pump standard head)	(kg)	154	153	154	195	195
Additional weight (dual pump standard head)	(kg)	184	183	183	225	225
Additional weight (single pump high head)	(kg)	163	163	162	205	208
Additional weight (dual pump high head)	(kg)	200	199	199	241	255
Additional shipping weight (buffer tank)	(kg)	326	326	326	326	326
Refrigerant & Oil Charge						
Refrigerant Charge (Circuit 1/Circuit 2)	(kg)	14.5	14.5	15.4	21.8	21.8
Oil Charge (Circuit 1/Circuit 2)	(L)	6.6	6.6	6.6	13.4	13.4

(1) Eurovent Conditions (Evap. 12°C/7°C - Air. 35°C)

(2) amps for base unit without pump package, without freeze protection

(3) without pump package

General Data

Table 11 - CGAM - High Efficiency Compact - DUPLEX V units

Size		40	46	52	60	70
Eurovent Performances (1)						
Net capacity	(kW)	112.9	128.8	143.5	163.9	193.8
Total power input	(kW)	36.0	40.7	46.9	51.9	62.7
EER		3.13	3.17	3.06	3.16	3.09
Main power supply		400/3/50	400/3/50	400/3/50	400/3/50	400/3/50
Sound power level	(dBA)	87.7	87.8	88.2	90.5	92.8
System Data						
Refrigerant circuit	#	2	2	2	2	2
Capacity steps	%	25-50-75-100	21-43-71-100	25-50-75-100	25-50-75-100	21-43-71-100
Units Amps (2)						
Maximum amps	(A)	90.8	100.8	110.8	132.3	155.0
Start-up amps - standard unit	(A)	212.7	233.7	243.7	261.8	330.3
Start-up amps - with soft starter option	(A)	140.7	163.7	173.7	208.8	254.3
Short circuit unit capacity	(kA)	15	15	15	15	15
Min supply cable size	(mm ²)	95	95	95	95	150
Max supply cable size	(mm ²)	150	150	150	150	240
Compressor						
Number	#	4	4	4	4	4
Type		Scroll	Scroll	Scroll	Scroll	Scroll
Model		CSHD125& CSHD125	CSHD125& CSHD161	CSHD161& CSHD161	CSHN184& CSHN184	CSHN184& CSHN250
Motor RPM	(rpm)	2900	2900	2900	2900	2900
Power factor	#	0.85	0.85	0.85	0.85	0.85
Sump heater per circuit	(W)	160&160	160&160	160&160	160&160	160&160
Evaporator						
Quantity	#	1	1	1	1	1
Type		BPHE	BPHE	BPHE	BPHE	BPHE
Water volume/storage (total)	(L)	9.1	14.3	15.6	18.9	28.2
Antifreeze heater	(W)	120		180		240
Min. flow	(L/Sec)	2.7	3.0	3.4	3.9	4.6
Max. flow	(L/Sec)	8.0	9.1	10.3	11.8	13.8
Pump Package (Option Standard Head)						
Nb Pump Set	#	1	1	1	1	1
Motor RPM	(rpm)	2890	2890	2890	2890	2890
Pump power (single / dual) - standard head	(kW)	3.0	4.0	4.0	4.0	5.5
Rated amps (single / dual) - standard head	(A)	6.1	7.59	7.59	7.59	10.6
Pump power (single / dual) - high head	(kW)	5.5	5.5	5.5	7.5	7.5
Rated amps (single / dual) - high head	(A)	10.6	10.6	10.6	13.8	13.8
Hydraulic Module Components						
Expansion tank volume	(L)	25	25	25	25	25
User volume expansion capacity	(L)	380	380	380	380	380
Max. Water-side pressure without pump	(kPa)	1000	1000	1000	1000	1000
Max. Water-side pressure with pump	(kPa)			400		
Antifreeze heater	(W)			120		
Pump package anti freeze heater	(W)			910		

General Data

Size		40	46	52	60	70
Water tank antifreeze heater	(W)			800		
Water tank volume	(L)	515	515	515	515	515
Condenser						
Type		Fin and Tube	Fin and Tube	Fin and Tube	Fin and Tube	Fin and Tube
Qty of coils	#	2	2	2	2	2
Fan						
Type		Propeller	Propeller	Propeller	Propeller	Propeller
Quantity per circuit	#	2	2	2	3	3
Diameter	(mm)	757	757	757	757	757
Drive type		Direct	Direct	Direct	Direct	Direct
Airflow per fan	(m ³ /h)	13341	13344	13347	13129	13133
Static pressure	(Pa)	0	0	0	0	0
Motor rpm	#	920	920	920	920	920
Unit Water Connection						
Chilled water	(mm)	65	65	80	80	80
Type (standard)		Grooved	Grooved	Grooved	Grooved	Grooved
Dimensions						
Unit length with buffer tank	(mm)	3416	3416	3416	4330	4330
Unit length without buffer tank	(mm)	2905	2905	2905	3819	3819
Unit width	(mm)	2266	2266	2266	2266	2266
Unit height	(mm)	2150	2150	2150	2150	2150
Weight						
Operating weight(3)	(kg)	1558	1573	1598	1996	2070
Shipping weight(3)	(kg)	1526	1539	1560	1955	2026
Additional weight (single pump standard head)	(kg)	171	177	178	179	187
Additional weight (dual pump standard head)	(kg)	209	221	221	222	237
Additional weight (single pump high head)	(kg)	179	179	179	222	223
Additional weight (dual pump high head)	(kg)	225	226	226	318	319
Additional shipping weight (buffer tank)	(kg)	382	381	381	381	381
Refrigerant & Oil Charge						
Refrigerant Charge (Circuit 1/Circuit 2)	(kg)	14.5/14.5	14.5/14.5	14.5/14.5	21.8/21.8	21.8/21.8
Oil Charge (Circuit 1/Circuit 2)	(L)	6.6 / 6.6	6.6 / 6.6	6.6 / 6.6	13.4 / 13.4	13.4 / 13.4

(1) Eurovent Conditions (Evap. 12°C/7°C - Air. 35°C)

(2) amps for base unit without pump package, without freeze protection

(3) without pump package

General Data

Table 12 - CGAM - High Efficiency Compact - DUPLEX W units

Size		80	90	100	110	120	140	150	160
Eurovent Performances (1)									
Net capacity	(kW)	224.1	254.6	282.8	311.7	332.4	391.7	419.2	443.3
Total power input	(kW)	72.1	80.0	89.9	97.6	107.3	124.6	133.1	141.2
EER		3.11	3.18	3.14	3.19	3.10	3.14	3.15	3.14
Main power supply		400/3/50	400/3/50	400/3/50	400/3/50	400/3/50	400/3/50	400/3/50	400/3/50
Sound power level	(dBA)	93.8	92.6	91.1	91.8	92.6	93.8	92.7	93.4
System Data									
Refrigerant circuit	#	2	2	2	2	2	2	2	2
Capacity steps	%	25-50-75-100	22-44-72-100	25-50-75-100	23-45-73-100	25-50-75-100	14-29-46-64-82-100	17-33-50-67-83-100	16-31-47-63-81-100
Units Amps (2)									
Maximum amps	(A)	169.4	196.5	219.4	237.0	250.4	307.3	330.2	347.8
Start-up amps - standard unit	(A)	344.6	405.3	428.2	499.1	512.5	516.1	539.0	609.9
Start-up amps - with soft starter option	(A)	268.6	324.3	347.2	382.1	395.5	435.1	458.0	492.9
Short circuit unit capacity	(kA)	15	15	15	15	15	15	15	15
Min supply cable size	(mm ²)	95	150	150	150	185	240	240	240
Max supply cable size	(mm ²)	240	240	240	240	240	240	240	240
Compressor									
Number	#	4	4	4	4	4	6	6	6
Type		Scroll	Scroll	Scroll	Scroll	Scroll	Scroll	Scroll	Scroll
Model		CSHN250&CSHN250	CSHN250&CSHN315	CSHN315&CSHN315	CSHN315&CSHN374	CSHN374&CSHN374	CSHN250&CSHN315&CSHN315	CSHN315&CSHN315&CSHN315	CSHN315&CSHN315&CSHN374
Motor RPM	(rpm)	2900	2900	2900	2900	2900	2900	2900	2900
Power factor	#	0.85	0.85	0.85	0.85	0.85	0.85	0.85	0.85
Sump heater per circuit	(W)	160&160	160&160	160&160	160&160	160&160	160&160	160&160	160&160
Evaporator									
Quantity	#	1	1	1	1	1	1	1	1
Type		BPHE	BPHE	BPHE	BPHE	BPHE	BPHE	BPHE	BPHE
Water volume/storage (total)	(L)	26.5	34.1	39.2	43.4	43.4	46.7	46.7	46.7
Antifreeze heater	(W)	240	300						
Min. flow	(L/Sec)	5.4	6.1	6.8	7.4	7.9	9.3	9.9	10.4
Max. flow	(L/Sec)	16.2	18.2	20.5	22.2	23.7	27.8	29.8	31.3
Pump Package (Option Standard Head)									
Nb Pump Set	#	1	1	1	1	1	1	1	1
Motor RPM	(rpm)	2890	2890	2890	2900	2900	2900	2900	2900
Pump power (single / dual) - standard head	(kW)	5.5	5.5	5.5	7.5	7.5	11.0	11.0	11.0
Rated amps (single / dual) - standard head	(A)	10.6	10.6	10.6	13.8	13.8	19.6	19.6	19.6
Pump power (single / dual) - high head	(kW)	7.5	7.5	7.5	7.5	11.0	11.0	11.0	15.0
Rated amps (single / dual) - high head	(A)	13.8	13.8	13.8	13.8	19.6	19.6	19.6	26.5
Hydraulic Module Components									
Expansion tank volume	(L)	60	60	60	60	60	60	60	60

General Data

Size		80	90	100	110	120	140	150	160
User volume expansion capacity	(L)	1750	1750	1750	1750	1750	1750	1750	1750
Max. Water-side pressure without pump	(kPa)	1000	1000	1000	1000	1000	1000	1000	1000
Max. Water-side pressure with pump	(kPa)	500	500	500	500	500	500	500	500
Antifreeze heater	(W)			240				300	
Pump package anti freeze heater	(W)				1150				
Water tank antifreeze heater	(W)	800	800	1200	1200	1200	1200	1200	1200
Water tank volume	(L)	592	592	762	762	762	762	762	762
Condenser									
Type		Fin and Tube	Fin and Tube	Fin and Tube	Fin and Tube	Fin and Tube	Fin and Tube	Fin and Tube	Fin and Tube
Qty of coils	#	4	4	4	4	4	4	4	4
Fan									
Type		Propeller	Propeller	Propeller	Propeller	Propeller	Propeller	Propeller	Propeller
Quantity per circuit	#	3	3	4	4	4	5	6	6
Diameter	(mm)	757	757	757	757	757	757	757	757
Drive type		Direct	Direct	Direct	Direct	Direct	Direct	Direct	Direct
Airflow per fan	(m3/h)	13158	13162	12794	12796	12799	12796	12793	12795
Static pressure	(Pa)	0	0	0	0	0	0	0	0
Motor rpm	#	920	920	920	920	920	920	920	920
Unit Water Connection									
Chilled water	(mm)	100	100	100	100	100	100	100	100
Type (standard)		Grooved	Grooved	Grooved	Grooved	Grooved	Grooved	Grooved	Grooved
Dimensions									
Unit length with buffer tank	(mm)	3647	3647	4230	4230	4230	5145	6062	6062
Unit length without buffer tank	(mm)	3647	3647	4230	4230	4230	5145	6062	6062
Unit width	(mm)	2273	2273	2273	2273	2273	2273	2273	2273
Unit height	(mm)	2344	2344	2344	2344	2344	2344	2344	2344
Weight									
Operating weight(3)	(kg)	2334	2498	2706	2823	2823	3408	3810	3900
Shipping weight(3)	(kg)	2285	2448	2652	2762	2762	3344	3743	3832
Additional weight (single pump standard head)	(kg)	274	274	273	315	315	376	422	423
Additional weight (dual pump standard head)	(kg)	325	325	325	405	406	510	555	556
Additional weight (single pump high head)	(kg)	311	310	310	310	356	377	422	435
Additional weight (dual pump high head)	(kg)	407	406	406	407	489	510	555	583
Additional shipping weight (buffer tank)	(kg)	203	203	252	252	252	253	252	252
Refrigerant & Oil Charge									
Refrigerant Charge (Circuit 1/Circuit 2)	(kg)	33.6/33.6	33.6/33.6	37.2/37.2	38.1/38.1	38.1/38.1	50.8/50.8	58.1/58.1	59/59
Oil Charge (Circuit 1/Circuit 2)	(L)	13.4 / 13.4	13.4 / 13.4	13.4 / 13.4	13.9 / 13.9	14.4 / 14.4	20.1 / 20.1	20.1 / 20.1	20.6 / 20.6

(1) Eurovent Conditions (Evap. 12°C/7°C - Air. 35°C)
 (2) amps for base unit without pump package, without freeze protection
 (3) without pump package

General Data

Table 13 - CGAM - High Efficiency Super Quiet - SIMPLEX units

Size		20	23	26	30	35
Eurovent Performances (1)						
Net capacity	(kW)	58.1	63.7	73.8	82.1	97.0
Total power input	(kW)	18.4	20.4	23.8	26.5	31.7
EER		3.15	3.12	3.10	3.10	3.06
Main power supply		400/3/50	400/3/50	400/3/50	400/3/50	400/3/50
Sound power level	(dBA)	79.5	79.5	79.6	81.8	83.9
System Data						
Refrigerant circuit	#	1	1	1	1	1
Capacity steps	%	50-100	43-100	50-100	50-100	43-100
Units Amps (2)						
Maximum amps	(A)	45.9	50.9	55.9	66.7	78.0
Start-up amps - standard unit	(A)	167.8	183.8	188.8	196.2	253.3
Start-up amps - with soft starter option	(A)	95.8	113.8	118.8	143.2	177.3
Short circuit unit capacity	(kA)	15	15	15	15	15
Min supply cable size	(mm ²)	50	50	50	50	50
Max supply cable size	(mm ²)	95	95	95	95	95
Compressor						
Number	#	2	2	2	2	2
Type		Scroll	Scroll	Scroll	Scroll	Scroll
Model		CSHD125& CSHD125	CSHD125& CSHD161	CSHD161& CSHD161	CSHN184& CSHN184	CSHN184& CSHN250
Motor RPM	(rpm)	2900	2900	2900	2900	2900
Power factor	#	0.85	0.85	0.85	0.85	0.85
Sump heater per circuit	(W)	90&90	90&90	90&90	160&160	160&160
Evaporator						
Quantity	#	1	1	1	1	1
Type		BPHE	BPHE	BPHE	BPHE	BPHE
Water volume/storage (total)	(L)	5.3	5.3	8.2	8.2	12.1
Antifreeze heater	(W)		120			180
Min. flow	(L/ Sec)	1.4	1.5	1.7	2.0	2.3
Max. flow	(L/ Sec)	4.1	4.6	5.2	5.9	6.8
Pump Package (Option Standard Head)						
Nb Pump Set	#	1	1	1	1	1
Motor RPM	(rpm)	2860	2860	2860	2860	2860
Pump power (single / dual) - standard head	(kW)	1.5	1.5	1.5	1.5	1.5
Rated amps (single / dual) - standard head	(A)	3.25	3.25	3.25	3.25	3.25
Pump power (single / dual) - high head	(kW)	4.0	4.0	4.0	4.0	5.5
Rated amps (single / dual) - high head	(A)	7.59	7.59	7.59	7.59	10.6
Hydraulic Module Components						
Expansion tank volume	(L)	25	25	25	25	25
User volume expansion capacity	(L)	380	380	380	380	380
Max. Water-side pressure without pump	(kPa)	1000	1000	1000	1000	1000
Max. Water-side pressure with pump	(kPa)			400		
Antifreeze heater	(W)			180		

General Data

Size		20	23	26	30	35
Pump package anti freeze heater	(W)			530		
Water tank antifreeze heater	(W)			860		
Water tank volume	(L)			500		
Condenser						
Type		Fin and Tube	Fin and Tube	Fin and Tube	Fin and Tube	Fin and Tube
Qty of coils	#	1	1	1	1	1
Fan						
Type		Propeller	Propeller	Propeller	Propeller	Propeller
Quantity per circuit	#	2	2	2	3	3
Diameter	(mm)	732	732	732	732	732
Drive type		Direct	Direct	Direct	Direct	Direct
Airflow per fan	(m3/h)	13245	13249	13254	12890	12896
Static pressure	(Pa)	0	0	0	0	0
Motor rpm	#	700	700	700	700	700
Unit Water Connection						
Chilled water	(mm)	50	50	50	65	65
Type (standard)		Grooved	Grooved	Grooved	Grooved	Grooved
Dimensions						
Unit length with buffer tank	(mm)	3418	3418	3418	4332	4332
Unit length without buffer tank	(mm)	2908	2908	2908	3822	3822
Unit width	(mm)	1280	1280	1280	1280	1280
Unit height	(mm)	2145	2145	2145	2145	2145
Weight						
Operating weight(3)	(kg)	888	887	902	1105	1161
Shipping weight(3)	(kg)	860	860	873	1074	1128
Additional weight (single pump standard head)	(kg)	154	153	154	195	195
Additional weight (dual pump standard head)	(kg)	184	183	183	225	225
Additional weight (single pump high head)	(kg)	163	163	162	205	208
Additional weight (dual pump high head)	(kg)	200	199	199	241	255
Additional shipping weight (buffer tank)	(kg)	326	326	326	326	326
Refrigerant & Oil Charge						
Refrigerant Charge (Circuit 1/Circuit 2)	(kg)	15.4	15.4	15.4	21.8	21.8
Oil Charge (Circuit 1/Circuit 2)	(L)	6.6	6.6	6.6	13.4	13.4

(1) Eurovent Conditions (Evap. 12°C/7°C - Air. 35°C)

(2) amps for base unit without pump package, without freeze protection

(3) without pump package

General Data

Table 14 - CGAM - High Efficiency Super Quiet - DUPLEX V units

Size		40	46	52	60	70
Eurovent Performances (1)						
Net capacity	(kW)	112.5	128.7	143.4	164.1	193.5
Total power input	(kW)	36.2	40.7	46.9	52.3	62.8
EER		3.11	3.17	3.06	3.14	3.08
Main power supply		400/3/50	400/3/50	400/3/50	400/3/50	400/3/50
Sound power level	(dBA)	82.5	82.3	82.5	84.9	87.0
System Data						
Refrigerant circuit	#	2	2	2	2	2
Capacity steps	%	25-50-75-100	21-43-71-100	25-50-75-100	25-50-75-100	21-43-71-100
Units Amps (2)						
Maximum amps	(A)	90.8	100.8	110.8	132.3	155.0
Start-up amps - standard unit	(A)	212.7	233.7	243.7	261.8	330.3
Start-up amps - with soft starter option	(A)	140.7	163.7	173.7	208.8	254.3
Short circuit unit capacity	(kA)	15	15	15	15	15
Min supply cable size	(mm ²)	95	95	95	95	150
Max supply cable size	(mm ²)	150	150	150	150	240
Compressor						
Number	#	4	4	4	4	4
Type		Scroll	Scroll	Scroll	Scroll	Scroll
Model		CSHD125& CSHD125	CSHD125& CSHD161	CSHD161& CSHD161	CSHN184& CSHN184	CSHN184& CSHN250
Motor RPM	(rpm)	2900	2900	2900	2900	2900
Power factor	#	0.85	0.85	0.85	0.85	0.85
Sump heater per circuit	(W)	160&160	160&160	160&160	160&160	160&160
Evaporator						
Quantity	#	1	1	1	1	1
Type		BPHE	BPHE	BPHE	BPHE	BPHE
Water volume/storage (total)	(L)	9.1	14.3	15.6	18.9	28.2
Antifreeze heater	(W)	120		180		240
Min. flow	(L/Sec)	2.7	3.0	3.4	3.9	4.6
Max. flow	(L/Sec)	8.0	9.1	10.3	11.8	13.8
Pump Package (Option Standard Head)						
Nb Pump Set	#	1	1	1	1	1
Motor RPM	(rpm)	2890	2890	2890	2890	2890
Pump power (single / dual) - standard head	(kW)	3.0	4.0	4.0	4.0	5.5
Rated amps (single / dual) - standard head	(A)	6.1	7.59	7.59	7.59	10.6
Pump power (single / dual) - high head	(kW)	5.5	5.5	5.5	7.5	7.5
Rated amps (single / dual) - high head	(A)	10.6	10.6	10.6	13.8	13.8
Hydraulic Module Components						
Expansion tank volume	(L)	25	25	25	25	25
User volume expansion capacity	(L)	380	380	380	380	380
Max. Water-side pressure without pump	(kPa)	1000	1000	1000	1000	1000
Max. Water-side pressure with pump	(kPa)			400		
Antifreeze heater	(W)			120		
Pump package anti freeze heater	(W)			910		

General Data

Size		40	46	52	60	70
Water tank antifreeze heater	(W)			800		
Water tank volume	(L)	515	515	515	515	515
Condenser						
Type		Fin and Tube	Fin and Tube	Fin and Tube	Fin and Tube	Fin and Tube
Qty of coils	#	2	2	2	2	2
Fan						
Type		Propeller	Propeller	Propeller	Propeller	Propeller
Quantity per circuit	#	2	2	2	3	3
Diameter	(mm)	732	732	732	732	732
Drive type		Direct	Direct	Direct	Direct	Direct
Airflow per fan	(m3/h)	13244	13248	13254	12890	12896
Static pressure	(Pa)	0	0	0	0	0
Motor rpm	#	700	700	700	700	700
Unit Water Connection						
Chilled water	(mm)	65	65	80	80	80
Type (standard)		Grooved	Grooved	Grooved	Grooved	Grooved
Dimensions						
Unit length with buffer tank	(mm)	3416	3416	3416	4330	4330
Unit length without buffer tank	(mm)	2905	2905	2905	3819	3819
Unit width	(mm)	2266	2266	2266	2266	2266
Unit height	(mm)	2150	2150	2150	2150	2150
Weight						
Operating weight(3)	(kg)	1558	1573	1598	1996	2070
Shipping weight(3)	(kg)	1526	1539	1560	1955	2026
Additional weight (single pump standard head)	(kg)	171	177	178	179	187
Additional weight (dual pump standard head)	(kg)	209	221	221	222	237
Additional weight (single pump high head)	(kg)	179	179	179	222	223
Additional weight (dual pump high head)	(kg)	225	226	226	318	319
Additional shipping weight (buffer tank)	(kg)	382	381	381	381	381
Refrigerant & Oil Charge						
Refrigerant Charge (Circuit 1/Circuit 2)	(kg)	14.5/14.5	14.5/14.5	14.5/14.5	21.8/21.8	21.8/21.8
Oil Charge (Circuit 1/Circuit 2)	(L)	6.6 / 6.6	6.6 / 6.6	6.6 / 6.6	13.4 / 13.4	13.4 / 13.4

(1) Eurovent Conditions (Evap. 12°C/7°C - Air. 35°C)

(2) amps for base unit without pump package, without freeze protection

(3) without pump package

General Data

Table 15 - CGAM - High Efficiency Super Quiet - DUPLEX W units

Size		80	90	100	110	120	140	150	160
Eurovent Performances (1)									
Net capacity	(kW)	225.1	254.8	283.4	311.7	332.3	391.6	419.7	443.2
Total power input	(kW)	71.5	79.8	89.4	97.5	107.1	124.4	132.7	140.8
EER		3.15	3.19	3.17	3.20	3.10	3.15	3.16	3.15
Main power supply		400/3/50	400/3/50	400/3/50	400/3/50	400/3/50	400/3/50	400/3/50	400/3/50
Sound power level	(dBA)	87.8	86.6	85.4	86.5	87.3	87.9	86.7	87.9
System Data									
Refrigerant circuit	#	2	2	2	2	2	2	2	2
Capacity steps	%	25-50-75-100	22-44-72-100	25-50-75-100	23-45-73-100	25-50-75-100	14-29-46-64-82-100	17-33-50-67-83-100	16-31-47-63-81-100
Units Amps (2)									
Maximum amps	(A)	169.4	196.5	219.4	237.0	250.4	307.3	330.2	347.8
Start-up amps - standard unit	(A)	344.6	405.3	428.2	499.1	512.5	516.1	539.0	609.9
Start-up amps - with soft starter option	(A)	268.6	324.3	347.2	382.1	395.5	435.1	458.0	492.9
Short circuit unit capacity	(kA)	15	15	15	15	15	15	15	15
Min supply cable size	(mm ²)	95	150	150	150	185	240	240	240
Max supply cable size	(mm ²)	240	240	240	240	240	240	240	240
Compressor									
Number	#	4	4	4	4	4	6	6	6
Type		Scroll	Scroll	Scroll	Scroll	Scroll	Scroll	Scroll	Scroll
Model		CSHN250&CSHN250	CSHN250&CSHN315	CSHN315&CSHN315	CSHN315&CSHN374	CSHN374&CSHN374	CSHN250&CSHN315&CSHN315	CSHN315&CSHN315&CSHN315	CSHN315&CSHN315&CSHN374
Motor RPM	(rpm)	2900	2900	2900	2900	2900	2900	2900	2900
Power factor	#	0.85	0.85	0.85	0.85	0.85	0.85	0.85	0.85
Sump heater per circuit	(W)	160&160	160&160	160&160	160&160	160&160	160&160&160	160&160&160	160&160&160
Evaporator									
Quantity	#	1	1	1	1	1	1	1	1
Type		BPHE	BPHE	BPHE	BPHE	BPHE	BPHE	BPHE	BPHE
Water volume/storage (total)	(L)	26.5	34.1	39.2	43.4	43.4	46.7	46.7	46.7
Antifreeze heater	(W)		240				300		
Min. flow	(L/Sec)	5.4	6.1	6.8	7.4	7.9	9.2	9.9	10.4
Max. flow	(L/Sec)	16.2	18.2	20.5	22.2	23.7	27.7	29.6	31.3
Pump Package (Option Standard Head)									
Nb Pump Set	#	1	1	1	1	1	1	1	1
Motor RPM	(rpm)	2890	2890	2890	2900	2900	2900	2900	2900
Pump power (single / dual) - standard head	(kW)	5.5	5.5	5.5	7.5	7.5	11.0	11.0	11.0
Rated amps (single / dual) - standard head	(A)	10.6	10.6	10.6	13.8	13.8	19.6	19.6	19.6
Pump power (single / dual) - high head	(kW)	7.5	7.5	7.5	7.5	11.0	11.0	11.0	15.0
Rated amps (single / dual) - high head	(A)	13.8	13.8	13.8	13.8	19.6	19.6	19.6	26.5
Hydraulic Module Components									
Expansion tank volume	(L)	60	60	60	60	60	60	60	60

General Data

Size		80	90	100	110	120	140	150	160
User volume expansion capacity	(L)	1750	1750	1750	1750	1750	1750	1750	1750
Max. Water-side pressure without pump	(kPa)	1000	1000	1000	1000	1000	1000	1000	1000
Max. Water-side pressure with pump	(kPa)	500	500	500	500	500	500	500	500
Antifreeze heater	(W)			240				300	
Water tank antifreeze heater	(W)	800	800	1200	1200	1200	1200	1200	1200
Water tank volume	(L)	592	592	762	762	762	762	762	762
Condenser									
Type		Fin and Tube	Fin and Tube	Fin and Tube	Fin and Tube	Fin and Tube	Fin and Tube	Fin and Tube	Fin and Tube
Qty of coils	#	4	4	4	4	4	4	4	4
Fan									
Type		Propeller	Propeller	Propeller	Propeller	Propeller	Propeller	Propeller	Propeller
Quantity per circuit	#	3	3	4	4	4	5	5	6
Diameter	(mm)	732	732	732	732	732	732	732	732
Drive type		Direct	Direct	Direct	Direct	Direct	Direct	Direct	Direct
Airflow per fan	(m3/h)	13298	13301	12748	12751	12753	12751	13593	12749
Static pressure	(Pa)	0	0	0	0	0	0	0	0
Motor rpm	#	700	700	700	700	700	700	700	700
Unit Water Connection									
Chilled water	(mm)	100	100	100	100	100	100	100	100
Type (standard)		Grooved	Grooved	Grooved	Grooved	Grooved	Grooved	Grooved	Grooved
Dimensions									
Unit length with buffer tank	(mm)	3647	3647	4230	4230	4230	5145	6062	6062
Unit length without buffer tank	(mm)	3647	3647	4230	4230	4230	5145	6062	6062
Unit width	(mm)	2273	2273	2273	2273	2273	2273	2273	2273
Unit height	(mm)	2344	2344	2344	2344	2344	2344	2344	2344
Weight									
Operating weight(3)	(kg)	2334	2498	2706	2823	2823	3408	3810	3900
Shipping weight(3)	(kg)	2285	2448	2652	2762	2762	3344	3743	3832
Additional weight (single pump standard head)	(kg)	274	274	273	315	315	376	422	423
Additional weight (dual pump standard head)	(kg)	325	325	325	405	406	510	555	556
Additional weight (single pump high head)	(kg)	311	310	310	310	356	377	422	436
Additional weight (dual pump high head)	(kg)	407	406	406	407	489	510	555	582
Additional shipping weight (buffer tank)	(kg)	203	203	252	252	252	253	252	253
Refrigerant & Oil Charge									
Refrigerant Charge (Circuit 1/Circuit 2)	(kg)	33.6/33.6	33.6/33.6	37.2/37.2	39/39	38.1/38.1	50.8/50.8	58.1/58.1	59/59
Oil Charge (Circuit 1/Circuit 2)	(L)	13.4 / 13.4	13.4 / 13.4	13.4 / 13.4	13.9 / 13.9	14.4 / 14.4	20.1 / 20.1	20.1 / 20.1	20.6 / 20.6

(1) Eurovent Conditions (Evap. 12°C/7°C - Air. 35°C)

(2) amps for base unit without pump package, without freeze protection

(3) without pump package

General Data

Table 16 - CGAM - High Efficiency Comprehensive acoustic package - SIMPLEX units

Size		20	23	26	30	35
Eurovent Performances (1)						
Net capacity	(kW)	57.0	65.5	73.6	80.4	94.8
Total power input	(kW)	18.4	21.0	23.5	26.8	32.2
EER		3.10	3.11	3.13	3.00	2.95
Main power supply		400/3/50	400/3/50	400/3/50	400/3/50	400/3/50
Sound power level	(dBA)	76.4	76.4	78.3	79.3	82.0
System Data						
Refrigerant circuit	#	1	1	1	1	1
Capacity steps	%	50-100	43-100	50-100	50-100	43-100
Units Amps (2)						
Maximum amps	(A)	44.4	49.4	55.8	66.5	75.8
Start-up amps - standard unit	(A)	166.3	182.3	188.7	196.0	251.0
Start-up amps - with soft starter option	(A)	94.3	112.3	118.7	143.0	175.0
Short circuit unit capacity	(kA)	15	15	15	15	15
Min supply cable size	(mm ²)	50	50	50	50	50
Max supply cable size	(mm ²)	95	95	95	95	95
Compressor						
Number	#	2	2	2	2	2
Type		Scroll	Scroll	Scroll	Scroll	Scroll
Model		CSHD125& CSHD125	CSHD125& CSHD161	CSHD161& CSHD161	CSHN184& CSHN184	CSHN184& CSHN250
Motor RPM	(rpm)	2900	2900	2900	2900	2900
Power factor	#	0.85	0.85	0.85	0.85	0.85
Sump heater per circuit	(W)	90&90	90&90	90&90	160&160	160&160
Evaporator						
Quantity	#	1	1	1	1	1
Type		BPHE	BPHE	BPHE	BPHE	BPHE
Water volume/storage (total)	(L)	5.3	8.2	6.3	6.3	10.6
Antifreeze heater	(W)		120			180
Min. flow	(L/Sec)	1.4	1.5	1.7	1.9	2.2
Max. flow	(L/Sec)	4.1	4.6	5.2	5.7	6.7
Pump Package (Option Standard Head)						
Nb Pump Set	#	1	1	1	1	1
Motor RPM	(rpm)	2860	2860	2860	2860	2860
Pump power (single / dual) - standard head	(kW)	1.5	1.5	1.5	1.5	1.5
Rated amps (single / dual) - standard head	(A)	3.25	3.25	3.25	3.25	3.25
Pump power (single / dual) - high head	(kW)	4.0	4.0	4.0	4.0	5.5
Rated amps (single / dual) - high head	(A)	7.59	7.59	7.59	7.59	10.6
Hydraulic Module Components						
Expansion tank volume	(L)	25	25	25	25	25
User volume expansion capacity	(L)	380	380	380	380	380
Max. Water-side pressure without pump	(kPa)	1000	1000	1000	1000	1000
Max. Water-side pressure with pump	(kPa)			400		
Antifreeze heater	(W)			180		
Pump package anti freeze heater	(W)			530		

General Data

Size		20	23	26	30	35
Water tank antifreeze heater	(W)			860		
Water tank volume	(L)			500		
Condenser						
Type		Fin and Tube	Fin and Tube	Fin and Tube	Fin and Tube	Fin and Tube
Qty of coils	#	1	1	1	1	1
Fan						
Type		Propeller	Propeller	Propeller	Propeller	Propeller
Quantity per circuit	#	2	2	3	3	3
Diameter	(mm)	757	757	757	757	757
Drive type		Direct	Direct	Direct	Direct	Direct
Airflow per fan	(m3/h)	10077	10081	9500	9909	9913
Static pressure	(Pa)	0	0	0	0	0
Motor rpm	#	700	700	700	700	700
Unit Water Connection						
Chilled water	(mm)	50	50	65	65	65
Type (standard)		Grooved	Grooved	Grooved	Grooved	Grooved
Dimensions						
Unit length with buffer tank	(mm)	3418	3418	4332	4332	4332
Unit length without buffer tank	(mm)	2908	2908	3822	3822	3822
Unit width	(mm)	1280	1280	1280	1280	1280
Unit height	(mm)	2145	2145	2145	2145	2145
Weight						
Operating weight(3)	(kg)	923	932	1071	1187	1206
Shipping weight(3)	(kg)	894	903	1042	1158	1173
Additional weight (single pump standard head)	(kg)	154	154	196	195	195
Additional weight (dual pump standard head)	(kg)	184	183	226	225	225
Additional weight (single pump high head)	(kg)	162	162	206	204	208
Additional weight (dual pump high head)	(kg)	200	199	242	241	255
Additional shipping weight (buffer tank)	(kg)	325	326	326	326	326
Refrigerant & Oil Charge						
Refrigerant Charge (Circuit 1/Circuit 2)	(kg)	14.5	14.5	19.1	21.8	21.8
Oil Charge (Circuit 1/Circuit 2)	(L)	6.6	6.6	6.6	13.4	13.4

(1) Eurovent Conditions (Evap. 12°C/7°C - Air. 35°C)

(2) amps for base unit without pump package, without freeze protection

(3) without pump package

General Data

Table 17 - CGAM - High Efficiency Comprehensive acoustic package - DUPLEX V units

Size		40	46	52	60	70
Eurovent Performances (1)						
Net capacity	(kW)	111.9	126.9	147.7	164.4	190.5
Total power input	(kW)	36.2	41.3	46.7	53.3	63.8
EER		3.09	3.07	3.16	3.08	2.98
Main power supply		400/3/50	400/3/50	400/3/50	400/3/50	400/3/50
Sound power level	(dBA)	79.6	79.5	81.2	82.3	84.8
System Data						
Refrigerant circuit	#	2	2	2	2	2
Capacity steps	%	25-50-75-100	21-43-71-100	25-50-75-100	25-50-75-100	21-43-71-100
Units Amps (2)						
Maximum amps	(A)	87.8	97.8	110.5	132.0	150.5
Start-up amps - standard unit	(A)	209.7	230.7	243.4	261.5	325.8
Start-up amps - with soft starter option	(A)	137.7	160.7	173.4	208.5	249.8
Short circuit unit capacity	(kA)	15	15	15	15	15
Min supply cable size	(mm ²)	95	95	95	95	150
Max supply cable size	(mm ²)	150	150	150	150	240
Compressor						
Number	#	4	4	4	4	4
Type		Scroll	Scroll	Scroll	Scroll	Scroll
Model		CSHD125& CSHD125	CSHD125& CSHD161	CSHD161& CSHD161	CSHN184& CSHN184	CSHN184& CSHN250
Motor RPM	(rpm)	2900	2900	2900	2900	2900
Power factor	#	0.85	0.85	0.85	0.85	0.85
Sump heater per circuit	(W)	160&160	160&160	160&160	160&160	160&160
Evaporator						
Quantity	#	1	1	1	1	1
Type		BPHE	BPHE	BPHE	BPHE	BPHE
Water volume/storage (total)	(L)	14.3	14.3	15.6	18.9	28.2
Antifreeze heater	(W)		180			240
Min. flow	(L/Sec)	2.7	3.0	3.5	3.9	4.5
Max. flow	(L/Sec)	8.0	8.9	10.5	11.6	13.5
Pump Package (Option Standard Head)						
Nb Pump Set	#	1	1	1	1	1
Motor RPM	(rpm)	2890	2890	2890	2890	2890
Pump power (single / dual) - standard head	(kW)	3.0	4.0	4.0	4.0	5.5
Rated amps (single / dual) - standard head	(A)	6.1	7.59	7.59	7.59	10.6
Pump power (single / dual) - high head	(kW)	5.5	5.5	5.5	7.5	7.5
Rated amps (single / dual) - high head	(A)	10.6	10.6	10.6	13.8	13.8
Hydraulic Module Components						
Expansion tank volume	(L)	25	25	25	25	25
User volume expansion capacity	(L)	380	380	380	380	380
Max. Water-side pressure without pump	(kPa)	1000	1000	1000	1000	1000
Max. Water-side pressure with pump	(kPa)			400		
Antifreeze heater	(W)			120		
Pump package anti freeze heater	(W)			910		

General Data

Size		40	46	52	60	70
Water tank antifreeze heater	(W)			800		
Water tank volume	(L)	515	515	515	515	515
Condenser						
Type		Fin and Tube	Fin and Tube	Fin and Tube	Fin and Tube	Fin and Tube
Qty of coils	#	2	2	2	2	2
Fan						
Type		Propeller	Propeller	Propeller	Propeller	Propeller
Quantity per circuit	#	2	2	3	3	3
Diameter	(mm)	757	757	757	757	757
Drive type		Direct	Direct	Direct	Direct	Direct
Airflow per fan	(m3/h)	10077	10080	9500	9909	9913
Static pressure	(Pa)	0	0	0	0	0
Motor rpm	#	700	700	700	700	700
Unit Water Connection						
Chilled water	(mm)	65	65	80	80	80
Type (standard)		Grooved	Grooved	Grooved	Grooved	Grooved
Dimensions						
Unit length with buffer tank	(mm)	3416	3416	4330	4330	4330
Unit length without buffer tank	(mm)	2905	2905	3819	3819	3819
Unit width	(mm)	2266	2266	2266	2266	2266
Unit height	(mm)	2150	2150	2150	2150	2150
Weight						
Operating weight(3)	(kg)	1650	1658	1907	2150	2170
Shipping weight(3)	(kg)	1613	1621	1869	2109	2124
Additional weight (single pump standard head)	(kg)	170	177	179	179	187
Additional weight (dual pump standard head)	(kg)	208	221	223	222	237
Additional weight (single pump high head)	(kg)	178	178	181	222	222
Additional weight (dual pump high head)	(kg)	225	225	228	318	319
Additional shipping weight (buffer tank)	(kg)	382	381	381	381	381
Refrigerant & Oil Charge						
Refrigerant Charge (Circuit 1/Circuit 2)	(kg)	14.5/14.5	14.5/14.5	19.1/19.1	21.8/21.8	21.8/21.8
Oil Charge (Circuit 1/Circuit 2)	(L)	6.6 / 6.6	6.6 / 6.6	6.6 / 6.6	13.4 / 13.4	13.4 / 13.4

(1) Eurovent Conditions (Evap. 12°C/7°C - Air. 35°C)

(2) amps for base unit without pump package, without freeze protection

(3) without pump package

General Data

Table 18 - CGAM - High Efficiency Comprehensive acoustic package - DUPLEX W units

Size		80	90	100	110	120	140	150	160
Eurovent Performances (1)									
Net capacity	(kW)	225.9	255.6	281.2	302.5	331.9	391.2	414.4	433.5
Total power input	(kW)	69.2	78.1	89.8	97.1	104.6	122.7	134.1	144.2
EER		3.26	3.27	3.13	3.11	3.17	3.19	3.09	3.01
Main power supply		400/3/50	400/3/50	400/3/50	400/3/50	400/3/50	400/3/50	400/3/50	400/3/50
Sound power level	(dBA)	85.9	85.0	82.5	83.5	84.7	85.9	84.5	84.9
System Data									
Refrigerant circuit	#	2	2	2	2	2	2	2	2
Capacity steps	%	25-50-75-100	22-44-72-100	25-50-75-100	23-45-73-100	25-50-75-100	14-29-46-64-82-100	17-33-50-67-83-100	16-31-47-63-81-100
Units Amps (2)									
Maximum amps	(A)	169.1	194.7	217.6	231.0	247.1	302.5	325.4	338.8
Start-up amps - standard unit	(A)	344.3	403.5	426.4	493.1	509.2	511.3	534.2	600.9
Start-up amps - with soft starter option	(A)	268.3	322.5	345.4	376.1	392.2	430.3	453.2	483.9
Short circuit unit capacity	(kA)	15	15	15	15	15	15	15	15
Min supply cable size	(mm ²)	95	150	150	150	185	240	240	240
Max supply cable size	(mm ²)	150	240	240	240	240	240	240	240
Compressor									
Number	#	4	4	4	4	4	6	6	6
Type		Scroll	Scroll	Scroll	Scroll	Scroll	Scroll	Scroll	Scroll
Model		CSHN250&CSHN250	CSHN250&CSHN315	CSHN315&CSHN315	CSHN315&CSHN374	CSHN374&CSHN374	CSHN250&CSHN315&CSHN315	CSHN315&CSHN315&CSHN315	CSHN315&CSHN315&CSHN374
Motor RPM	(rpm)	2900	2900	2900	2900	2900	2900	2900	2900
Power factor	#	0.85	0.85	0.85	0.85	0.85	0.85	0.85	0.85
Sump heater per circuit	(W)	160&160	160&160	160&160	160&160	160&160	160&160&160	160&160&160	160&160&160
Evaporator									
Quantity	#	1	1	1	1	1	1	1	1
Type		BPHE	BPHE	BPHE	BPHE	BPHE	BPHE	BPHE	BPHE
Water volume/storage (total)	(L)	28.2	34.1	39.2	39.2	43.4	46.7	46.7	46.7
Antifreeze heater	(W)	240				300			
Min. flow	(L/Sec)	5.4	6.1	6.7	7.2	7.9	9.2	9.7	10.2
Max. flow	(L/Sec)	16.1	18.2	20.1	21.6	23.6	27.7	29.2	30.6
Pump Package (Option Standard Head)									
Nb Pump Set	#	1	1	1	1	1	1	1	1
Motor RPM	(rpm)	2890	2890	2890	2900	2900	2900	2900	2900
Pump power (single / dual) - standard head	(kW)	5.5	5.5	5.5	7.5	7.5	11.0	11.0	11.0
Rated amps (single / dual) - standard head	(A)	10.6	10.6	10.6	13.8	13.8	19.6	19.6	19.6
Pump power (single / dual) - high head	(kW)	7.5	7.5	7.5	7.5	11.0	11.0	11.0	15.0
Rated amps (single / dual) - high head	(A)	13.8	13.8	13.8	13.8	19.6	19.6	19.6	26.5
Hydraulic Module Components									
Expansion tank volume	(L)	60	60	60	60	60	60	60	60
User volume expansion capacity	(L)	1750	1750	1750	1750	1750	1750	1750	1750

General Data

Size		80	90	100	110	120	140	150	160
Max. Water-side pressure without pump	(kPa)	1000	1000	1000	1000	1000	1000	1000	1000
Max. Water-side pressure with pump	(kPa)	500	500	500	500	500	500	500	500
Antifreeze heater	(W)	240				300			
Pump package anti freeze heater	(W)	1150							
Water tank antifreeze heater	(W)	1200	1200	1200	1200	1200	1200	1200	1200
Water tank volume	(L)	762	762	762	762	762	762	762	762
Condenser									
Type		Fin and Tube	Fin and Tube	Fin and Tube	Fin and Tube	Fin and Tube	Fin and Tube	Fin and Tube	Fin and Tube
Qty of coils	#	4	4	4	4	4	4	4	4
Fan									
Type		Propeller	Propeller	Propeller	Propeller	Propeller	Propeller	Propeller	Propeller
Quantity per circuit	#	3	4	4	4	5	6	6	6
Diameter	(mm)	757	757	757	757	757	757	757	757
Drive type		Direct	Direct	Direct	Direct	Direct	Direct	Direct	Direct
Airflow per fan	(m3/h)	10291	9626	9629	10163	9627	9627	9628	9630
Static pressure	(Pa)	0	0	0	0	0	0	0	0
Motor rpm	#	700	700	700	700	700	700	700	700
Unit Water Connection									
Chilled water	(mm)	100	100	100	100	100	100	100	100
Type (standard)		Grooved	Grooved	Grooved	Grooved	Grooved	Grooved	Grooved	Grooved
Dimensions									
Unit length with buffer tank	(mm)	4230	4230	4230	5145	5145	6062	6062	6062
Unit length without buffer tank	(mm)	4230	4230	4230	5145	5145	6062	6062	6062
Unit width	(mm)	2273	2273	2273	2273	2273	2273	2273	2273
Unit height	(mm)	2344	2344	2344	2344	2344	2344	2344	2344
Weight									
Operating weight(3)	(kg)	2598	2798	2910	3163	3280	3946	4054	4054
Shipping weight(3)	(kg)	2552	2749	2856	3110	3220	3882	3986	3986
Additional weight (single pump standard head)	(kg)	274	273	274	335	337	422	423	423
Additional weight (dual pump standard head)	(kg)	324	324	324	426	428	556	556	556
Additional weight (single pump high head)	(kg)	310	310	310	332	377	423	423	436
Additional weight (dual pump high head)	(kg)	406	406	406	428	510	556	556	583
Additional shipping weight (buffer tank)	(kg)	252	252	252	252	252	252	253	252
Refrigerant & Oil Charge									
Refrigerant Charge (Circuit 1/Circuit 2)	(kg)	36.3/36.3	36.3/36.3	37.2/37.2	44.5/44.5	45.4/45.4	58.1/58.1	58.1/58.1	59/59
Oil Charge (Circuit 1/Circuit 2)	(L)	13.4 / 13.4	13.4 / 13.4	13.4 / 13.4	13.9 / 13.9	14.4 / 14.4	20.1 / 20.1	20.1 / 20.1	20.6 / 20.6

(1) Eurovent Conditions (Evap. 12°C/7°C - Air. 35°C)

(2) amps for base unit without pump package, without freeze protection

(3) without pump package

Dimensions

Figure 4 - CGAM units with/without Total Heat Recovery Option without Pump Package - W coil configuration

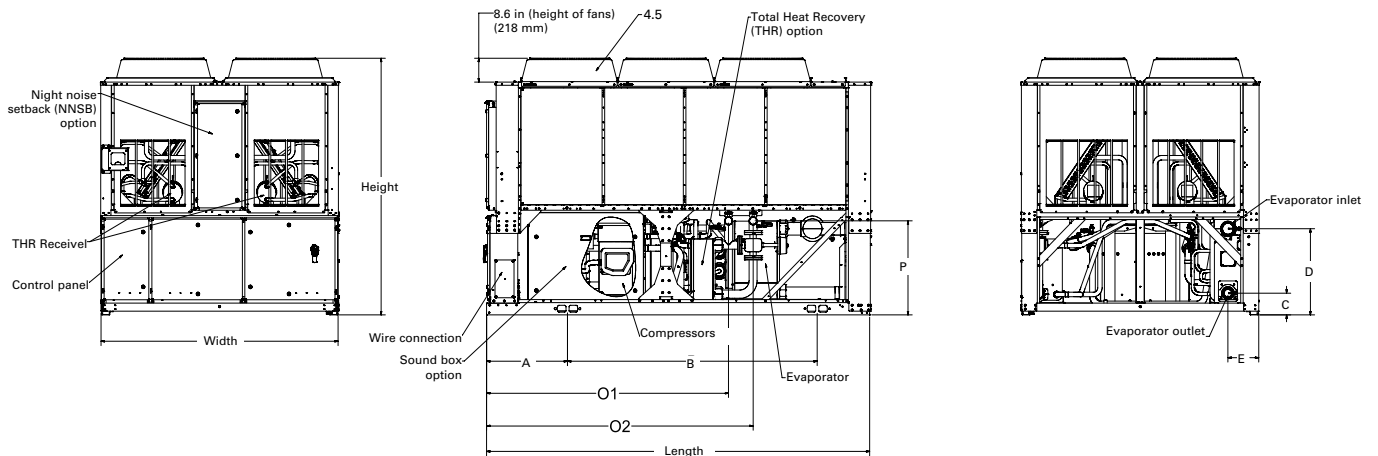
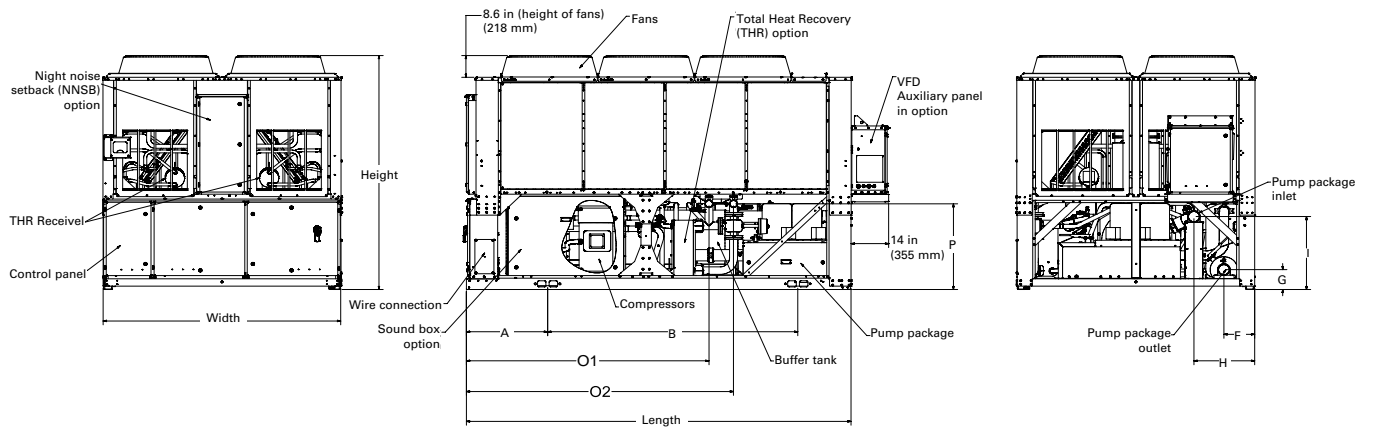

Figure 5 - CGAM units with/without Total Heat Recovery Option with Pump Package - W coil configuration



Dimensions

Figure 6 - CGAM units with/without Total Heat Recovery Option without Pump Package - V coil configuration

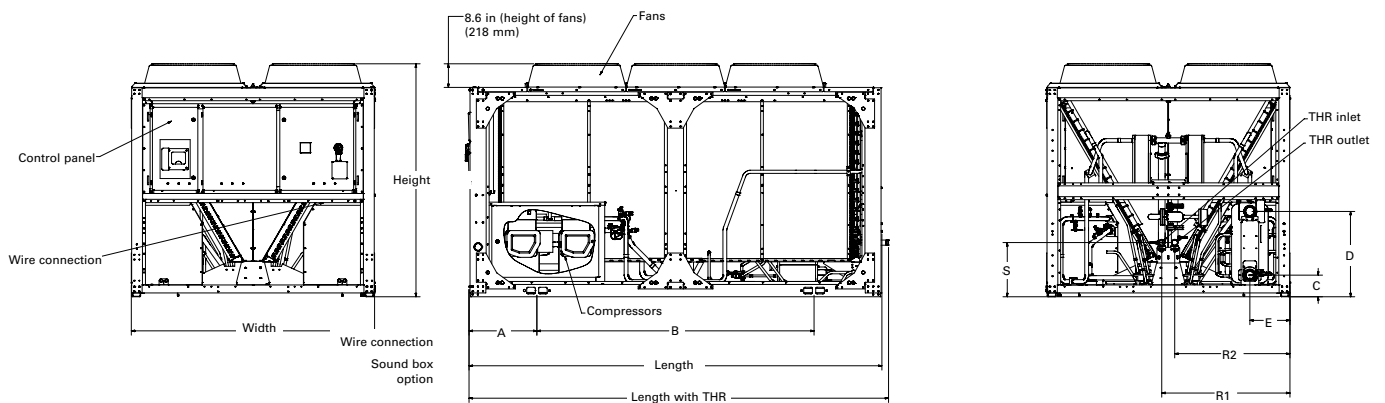
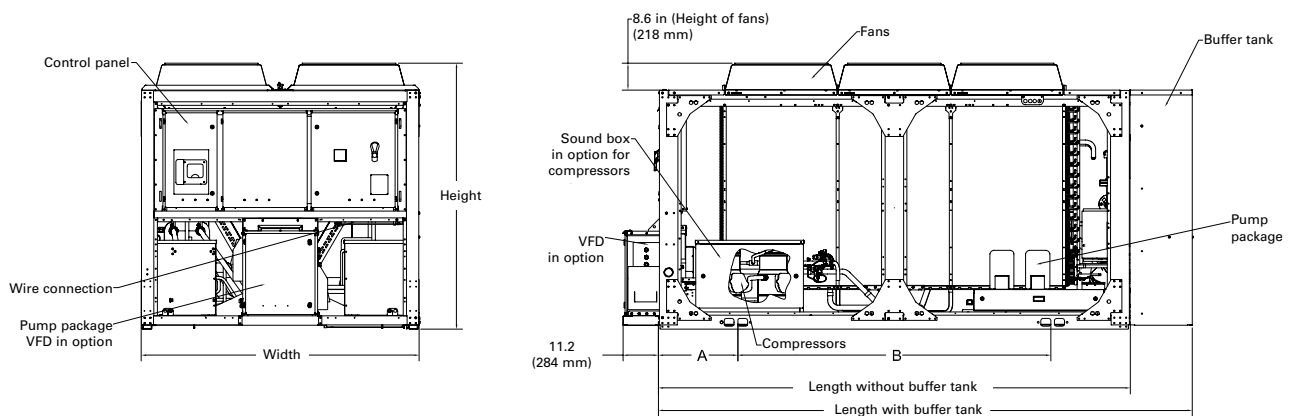

Figure 7 - CGAM units with/without Total Heat Recovery Option with Pump Package - V coil configuration



Dimensions

Figure 8 - Pump Package Water Connections - V coil configuration

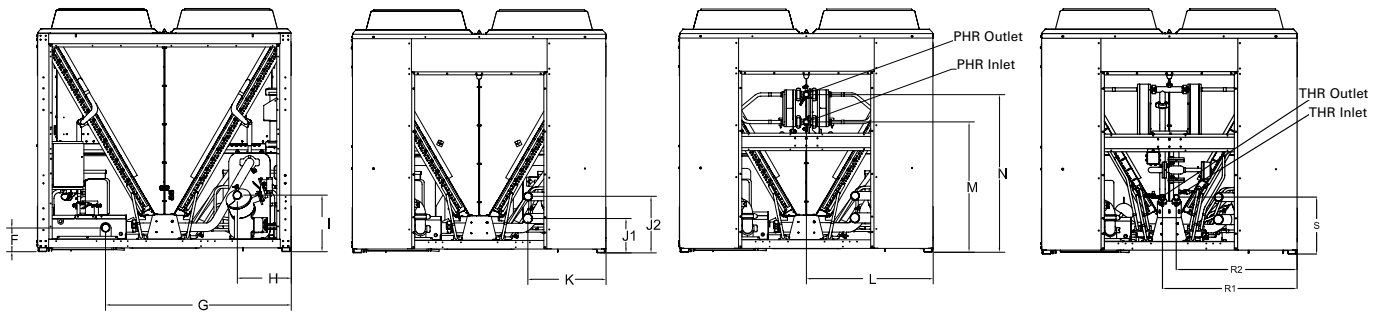

Figure 9 - V coil configuration

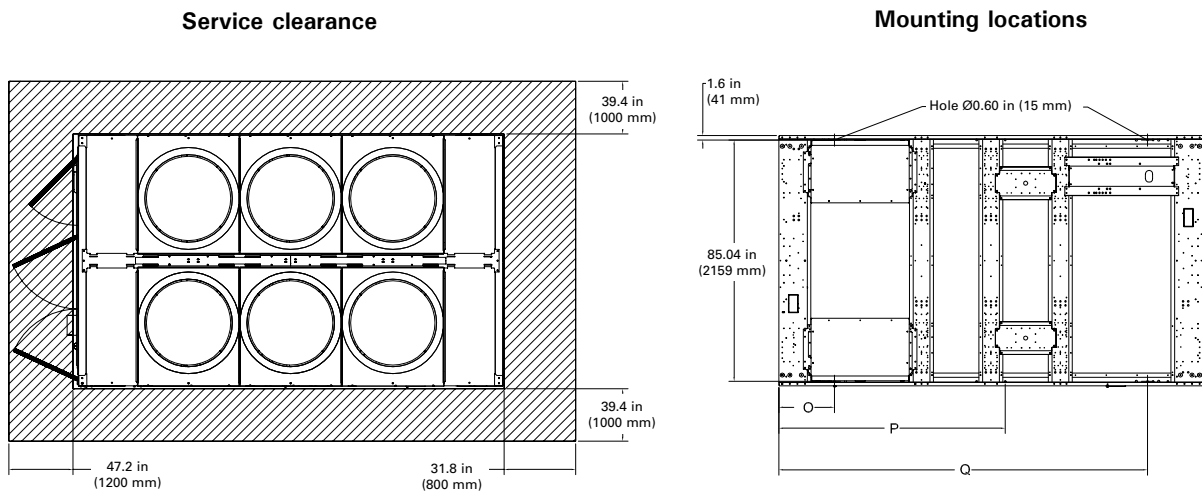
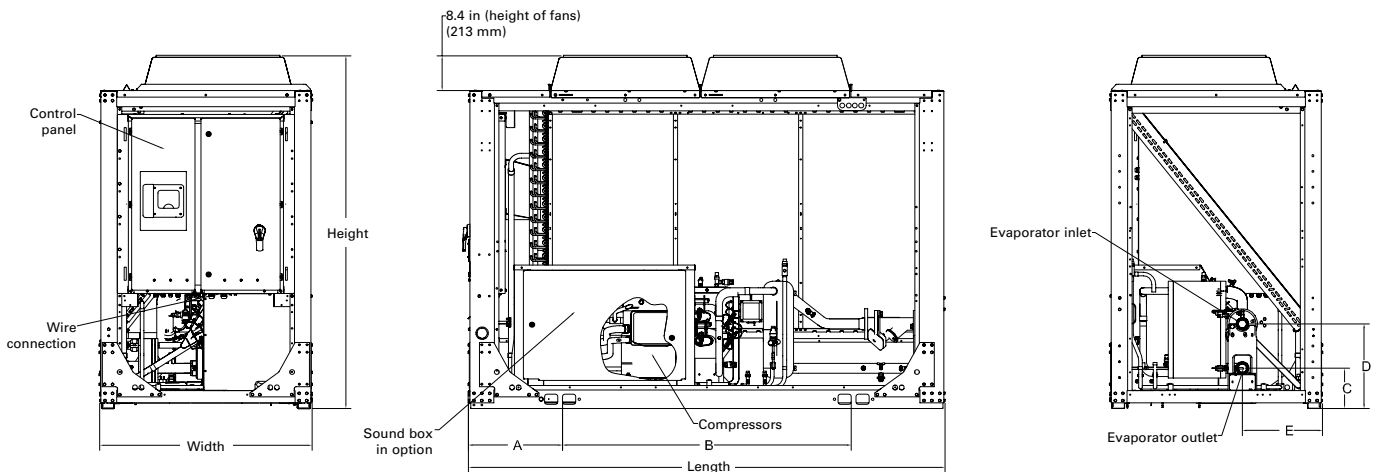

Figure 10 - Standard unit - S coil configuration



Dimensions

Figure 11 - Units with Pump Package - S coil configuration

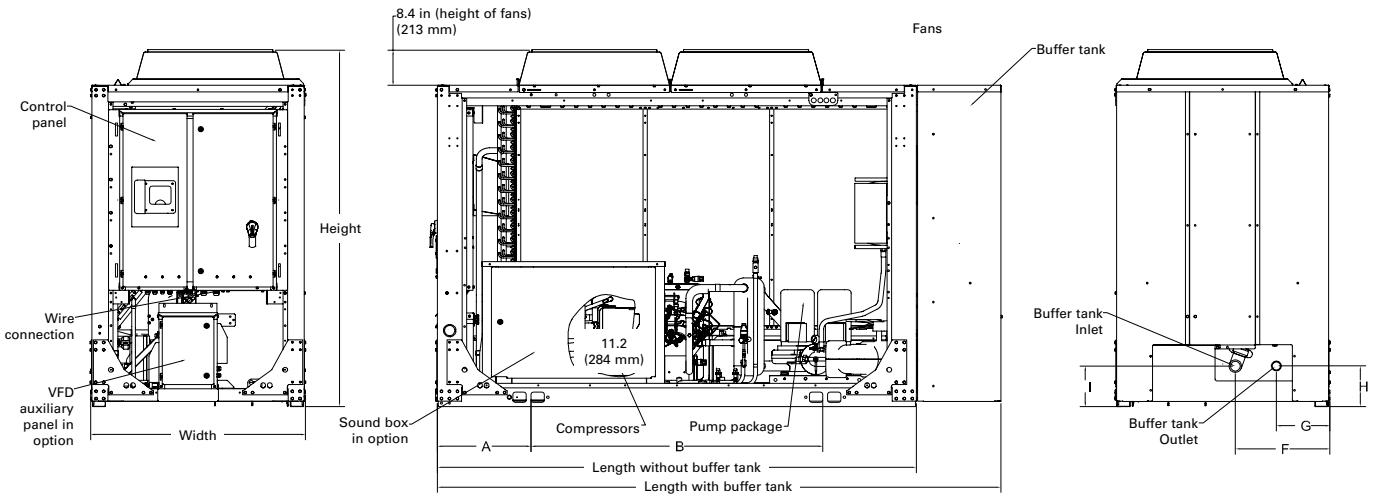

Figure 12 - Pump Package Water Connections - S coil configuration

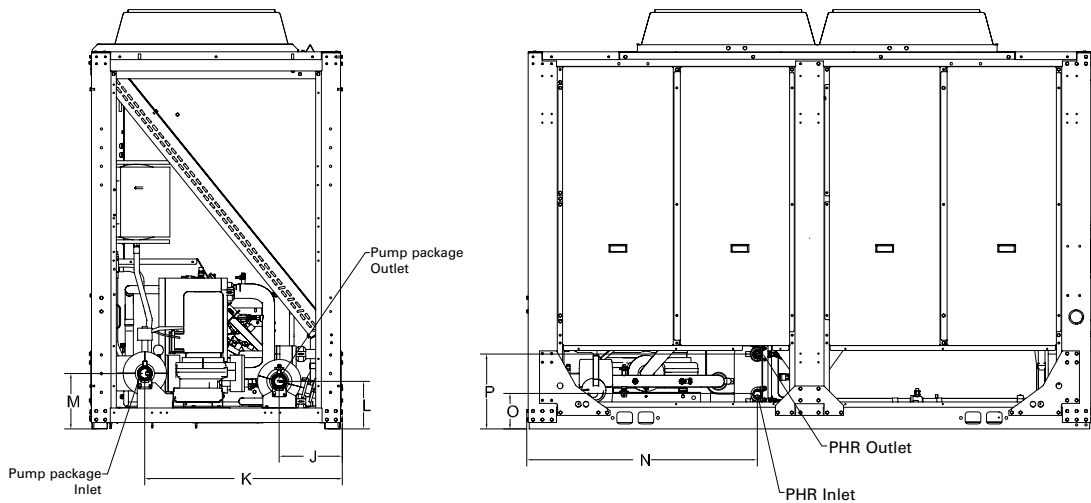
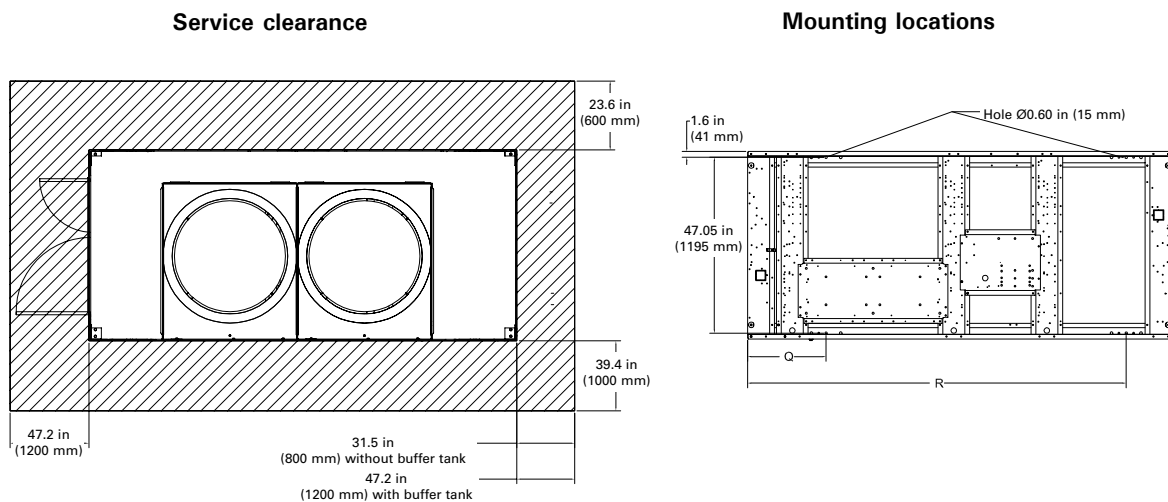

Figure 13 - S coil configuration



Dimensions

Table 19 - Dimensions DUPLEX W

		FRAME 1	FRAME 2	FRAME 3	FRAME 4
	Unit	(mm)	(mm)	(mm)	(mm)
	Length	3647	4230	5145	6062
	Width	2273	2273	2273	2273
	Height	2344	2344	2344	2344
Lifting holes	A	767	767	767	767
	B	2365	2055	3023	3833
EVP water connections (base unit)	C	198	198	198	198
	D	790	790	790	790
	E	292	292	292	292
EVP water connections (unit with pump package, without buffer tank)	F	292	292	292	292
	G	198	198	198	198
	H	574	574	574	574
	I	734	734	734	734
Isolators position	J	767	767	767	767
	K	2126	2267	1767	1767
	L			3317	4139
	M	3148	3731	4139	5566
Total Heat Recovery water connections	O1	2292	2875	2875	2875
	O2	2524	3107	3107	3107
	P	862	862	862	862

Table 20 - Dimensions DUPLEX V

		FRAME 1	FRAME 2
	Unit	(mm)	(mm)
		$\alpha \rightarrow$ Without buffer tank $b \rightarrow$ With buffer tank	$\alpha \rightarrow$ Without buffer tank $b \rightarrow$ With buffer tank
	Length	$\alpha \rightarrow$ 2905 $b \rightarrow$ 3416 $c \rightarrow$ 2968	$\alpha \rightarrow$ 3819 $b \rightarrow$ 4330 $c \rightarrow$ 3882
	Width	2266	2266
	Height	2150	2150
Lifting holes	A	618	618
	B	1650	2564
EVP water connections (base unit)	C	198	198
	D	655	790
	E	371	371
EVP water connections (unit with pump package, without buffer tank)	F	211	211
	G	1646	1646
	H	480	480
	I	500	500
EVP water connections (unit with buffer tank)	J1	303	303
	J2	501	501
	K	694	694
Partial Heat Recovery water connections	L	1125	1125
	M	1158	1158
	N	1392	1392
Isolators position	O	494	494
	P		2024
	Q	2388	3299
Total Heat Recovery water connections	R1	1185	1185
	R2	1065	1065
	S	501	501

Dimensions

Table 21 - Dimensions SIMPLEX

	Unit	FRAME 1		FRAME 2	
		Without buffer tank	With buffer tank	Without buffer tank	With buffer tank
		mm		mm	
Length		2908	3388	3822	4302
	Width	1301		1301	
Height		2145		2145	
Lifting holes	A	534		556	
	B	1867		2720	
EVP water connections (base unit)	C	246		246	
	D	516		516	
	E	488		488	
EVP water connections (unit with buffer tank)	F	572		572	
	G	325		325	
	H	249		249	
	I	244		244	
EVP water connections (unit with pump package, without buffer tank)	J	323		323	
	K	1016		1016	
	L	246		246	
	M	287		287	
Partial Heat Recovery water connections	N	1176		2091	
	O	182		182	
	P	385		385	
Isolators position	Q	534		558	
	R	2571		3358	

Installation – Mechanical

Location Requirements

Sound Considerations

- Refer to Trane Engineering Bulletin Chiller Sound Ratings and Installation Guide for sound consideration applications.
- Locate the unit away from sound-sensitive areas.
- Install the isolation pads under the unit. Refer to “Unit Isolation.”
- Install rubber vibration isolators in all water piping.
- Seal all wall penetrations.

Note: Consult an acoustical engineer for critical applications.

Foundation

Provide rigid, non-warping mounting pads or a concrete foundation of sufficient strength and mass to support the applicable operating weight (i.e., including completed piping, and full operating charges of refrigerant, oil and water). Refer to the chapter on “Unit Dimensions/Weights” for unit operating weights. Once in place, the unit must be level within 1/4” (6.4 mm) over its length and width. Trane is not responsible for equipment problems resulting from an improperly designed or constructed foundation.

Clearances

Provide enough space around the unit to allow the installation and maintenance personnel unrestricted access to all service points. Refer to submittal drawings for the unit dimensions, to provide sufficient clearance for the opening of control panel doors and unit service. Refer to the chapter on “Unit Dimensions/Weights” for minimum clearances. In all cases, local codes which require additional clearances will take precedence over these recommendations.

Rigging

Refer to weights tables for typical unit lifting weights. Refer to the rigging label attached to the unit for further details.

Lifting Procedure

Refer to the lifting label affixed to the unit. Lifting beam crossbars **MUST** be positioned so lifting cables do not contact the sides of the unit. Adjust as necessary for even level lift.

Installation – Mechanical

Unit isolation and leveling

Mounting

Construct an isolated concrete pad for the unit or provide concrete footings at each of the four unit mounting points. Mount the unit directly to the concrete pads or footings.

Level the unit using the base rail as a reference. The unit must be level within 6 mm over the entire length. Use shims as necessary to level the unit.

Neoprene Isolator Installation (optional)

Install the optional neoprene isolators at each mounting location. Isolators are identified by part number and color. Refer to unit submittals for further details on selection and location.

1. Secure the isolators to the mounting surface, using the mounting slots in the isolator base plate. Do not fully tighten the isolator mounting bolts at this time.
2. Align the mounting holes in the base of the unit, with the threaded positioning pins on the top of the isolators.
3. Lower the unit on to the isolators and secure the isolator to the unit with a nut. Maximum isolator deflection should be approximately 6 mm.
4. Level the unit carefully. Refer to "Leveling". Fully tighten the isolator mounting bolts.

Note: Consult a vibration engineer for critical applications.

Evaporator piping

Evaporator water connections are grooved. Thoroughly flush all water piping to the CGAM unit before making the final piping connections to the unit.

Components and layout will vary slightly, depending on the location of connections and the water source.

CAUTION Equipment Damage!

If using an acidic commercial flushing solution, construct a temporary bypass around the unit to prevent damage to internal components of the evaporator.

CAUTION Proper Water Treatment!

The use of untreated or improperly treated water in a chiller may result in scaling, erosion, corrosion, algae or slime. It is recommended that the services of a qualified water treatment specialist be engaged to determine what water treatment, if any, is required. Trane assumes no responsibility for equipment failures which result from untreated or improperly treated water, or saline or brackish water.

Drainage

Locate the unit near a large capacity drain for water vessel drain-down during shutdown or repair. Condensers and evaporators are provided with drain connections. Refer to "Water Piping." All local and national codes apply.

Piping

A vent is provided on the top of the evaporator at the return end. Be sure to provide additional vents at high points in the piping to bleed air from the chilled water system. Install necessary pressure gauges to monitor the entering and leaving chilled water pressures.

Provide shutoff valves in lines to the gauges to isolate them from the system when they are not in use. Use rubber vibration eliminators to prevent vibration transmission through the water lines.

If desired, install thermometers in the lines to monitor entering and leaving water temperatures.

Install a balancing valve in the leaving water line to control water flow balance. Install shutoff valves on both the entering and leaving water lines so that the evaporator can be isolated for service. These valves are factory supplied with pump package option.

Make sure the water circuit includes all devices and controls used to provide proper water system operation and unit operating safety.

Entering Chilled Water Piping

- Water strainer (hole size 1.6 mm or smaller) (1)
- Air vents (to bleed air from system) (1)
- Water pressure gage with shutoff valves (1)
- Vibration eliminators
- Shutoff (isolation) valves (1)
- Thermometers (if desired)
- Relief valve (1)

Leaving Chilled Water Piping

- Air vents (to bleed air from system) (1)
- Water pressure tab with shutoff valves (1)
- Vibration eliminators
- Shutoff (isolation) valves (1)
- Thermometers
- Balancing valve (1)

(1) Can be factory mounted (option)

Installation – Mechanical

Minimal installation water content

The water volume is an important parameter because it allows as table chilled water temperature and avoids short cycle operation of the compressors.

Parameters which influence the water temperature stability

- Water loop volume.
- Load fluctuation.
- Number of capacity steps.
- Compressors rotation.
- Dead band (adjusted by control CH530).
- Minimum time between 2 starts of a compressor.

Minimum water volume for a comfort application

For comfort application we can allow water temperature fluctuation at part load. The parameter to take into account is the minimum operating time of the compressor. In order to avoid lubrication problem on a scroll compressor it must run at least 2 minutes (120seconds) before it stops.

The minimum volume can be determined by using the following formula:

$$\text{Volume} = \text{Cooling capacity} \times \text{Time} \times \text{highest capacity step (\%)} / \text{Specific heat} / \text{Dead band}$$

$$\text{Minimum operating time} = 120 \text{ seconds}$$

$$\text{Specific heat} = 4.18 \text{ kJ / kg}$$

$$\text{Average Dead band} = 3^{\circ}\text{C (or } 2^{\circ}\text{C)}$$

Note: To estimate the biggest step, it is usually more reliable to make a selection at lower ambient temperature where efficiency is higher and compressors steps bigger. It is also essential to take into account the brine specific heat, in case of the use of glycol.

Process applications will need more water volume to minimize the water temperature fluctuation at part load.

Table 22 - Minimum water volumes for comfort applications

Unit size	Capacity (kW)	Biggest step (%)	Minimum water volume (l)
20	55	50	263
23	63	57	344
26	70	50	335
30	80	50	383
35	95	57	518
39	110	50	526
45	122	56	654
50	135	50	646
40	110	25	263
46	125	29	347
52	140	25	335
60	160	25	383
70	190	29	527
80	220	25	526
90	250	28	670
100	280	25	670
110	310	27	801
120	330	25	789
140	390	18	672
150	420	17	683
160	440	19	800
170	460	18	792

Installation – Mechanical

Expansion tank (option)

The factory-installed expansion tank initial pressure should be adjusted about 0.2 bar lower than the static pressure of the circuit at the pump inlet.

The expansion tank volume has been selected for typical loop volume. It is recommended to check the expansion tank volume with the installation information.

The following data is required:

- C = Water capacity of the circuit
- e = Expansion coefficient difference between max and min water temperature, in operation or not.
- Pi = Initial pressure of the expansion tank
- Pf = Final pressure: Max is given by the pressure relief valve

Minimum Volume of expansion tank
 $= (C \times e) / (1 - P_i / P_f)$

Expansion coefficient of water at various temperatures

°C	e
0	0.00013
10	0.00027
20	0.00177
30	0.00435
40	0.00782
50	0.01210

Freeze Protection

If the unit is exposed to ambient temperatures between 0°C and -18°C, the chilled water system must be protected from freezing following one of the options shown below:

1. Heaters
 - a. Heaters can be factory-installed (option) on the evaporator and water piping and will protect it from freezing in ambient temperatures down to -18°C.

AND

- b. Install heat tape on all water piping, pumps, and other components that may be damaged if exposed to freezing temperatures. Heat tape must be designed for low ambient temperature applications. Heat tape selection should be based on the lowest expected ambient temperature.

OR

2. Freeze inhibitor
 - a. Add a freeze inhibitor fluid to the chilled water system. The solution must be strong enough to provide protection against ice formation at the lowest anticipated ambient temperature.

Note: Use of a freeze inhibitor fluid reduces the cooling capacity of the unit and must be considered in the design of the system specifications.

3. Water pump

- a: Dynaview controller can start the pump to prevent freezing. This function needs to be validated, pump has to be controlled by the unit and water circuit valves need to stay open at all times.

If ambient temperatures below -18°C, the water circuit must be protected against freezing.

Add a freeze inhibitor fluid and activate the heat tape on the unit; do not shut the unit down.

Note: It is not recommended to drain the water circuit for the following reasons.

1. The water circuit will rust and its lifetime could be reduced.
2. Water will remain in the bottom of the plate heat exchangers and freeze damage could occur.

Note: If CH530 water pump control is enabled the CH530 will request start of customer pump during ambient air temperatures below freezing.

CAUTION! When using freeze inhibitor, never fill the system with pure glycol.

Always fill the system with diluted solution. Maximum concentration of glycol is 40%. Higher glycol concentration will damage pump seal.

Installation – Mechanical

Low refrigeration temperature setpoint and antifreeze setpoint on CH530

CAUTION! The chiller is provided with standard factory settings. It can be necessary to modify the Low Pressure saturation Temperature and the Antifreeze Setpoint on the unit control. Based on the following examples, it is necessary to modify on the CH530 the following settings:

- The LP saturation temperature
- The antifreeze setpoint

Examples

For:

- 7°C, the LP setting must be -4°C where the antifreeze setting shall be 2°C
- 2°C, the LP setting must be -9°C where the antifreeze setting shall be -4°C
- -12°C, the LP setting must be -23°C where the antifreeze setting shall be -17°C

Freeze protection with glycol

It is mandatory to use a freeze inhibitor for leaving water setpoint less or equal to 5°C. On the glycol recommended concentration figure, you must select concentration on or above the curve. For example, for -4°C brine temperature, a concentration of 25% ethylene glycol is not sufficient. The concentration must be 28% ethylene glycol or 33% propylene glycol.

Using glycol with hydraulic module

If the glycol brine percentage is not at the recommended percentage (greyed area), corrosion inhibitor present in the glycol may not be efficient enough. For instance, a glycol concentration of 15% will provide freeze protection to the unit down to -5°C, but it might generate additional corrosion.

Figure 14 - LP setting Vs. Leaving Water Temperature setpoint

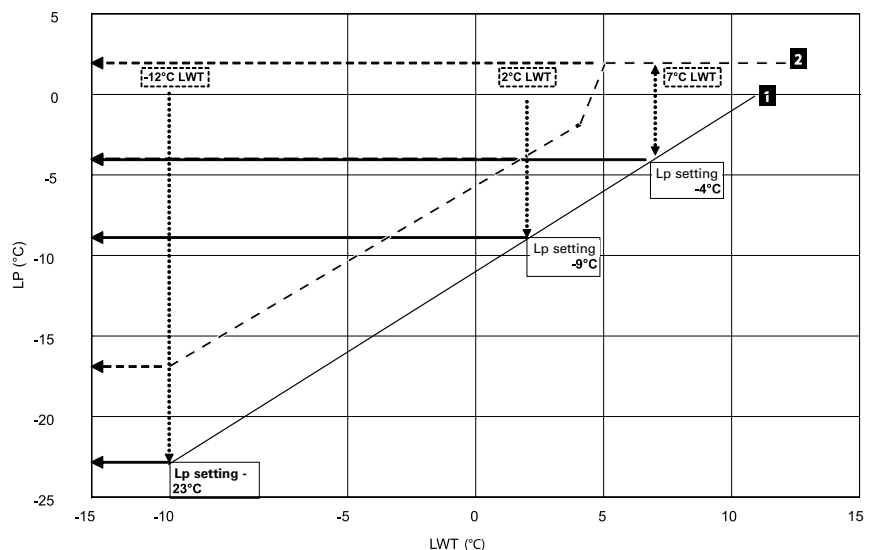

1. Low ref TEMP setpoint (SAT Temp) CH530
2. Antifreeze setpoint Vs. LWT

Installation – Mechanical

Figure 15 - Glycol percentage recommendation curve

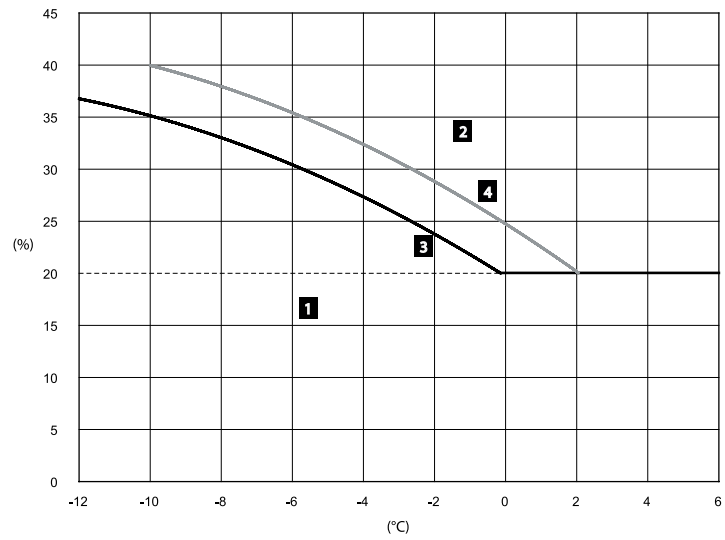

- 1 = Critical risks of freezing
- 2 = Efficient freeze protection
- 3 = Ethylene glycol
- 4 = Propylene glycol
- % = Glycol percentage (mass concentration)
- °C = Glycol or water temperature

Water pressure drops

Figure 16 - Pressure drops (through the evaporator - S configuration)

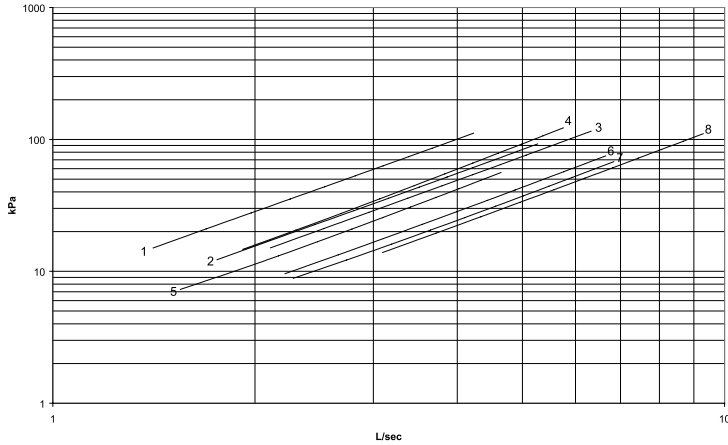

- 1 20 SE - 23SE - 26 SE SQ - 26 SE CP
- 2 20 HE - 23 HE SQ - 23 HE CP
- 3 30 SE SQ - 30 SE CP - 35 SE SQ - 35 SE CP
- 4 26 HE CAP - 30 HE CAP
- 5 26 HE CAP 60Hz - 26 HE SQ - 26 HE CP - 30 HE CAP 60Hz - 30 HE SQ - 30 HE CP
- 6 35 HE CAP - 35 SE CAP - 39 SE - 45 SE
- 7 35 HE CAP 60Hz - 35 HE SQ - 35 HE CP
- 8 50 SE SQ - 50 SE CP

Figure 17 - Pressure drops (through the evaporator - V and W configurations)

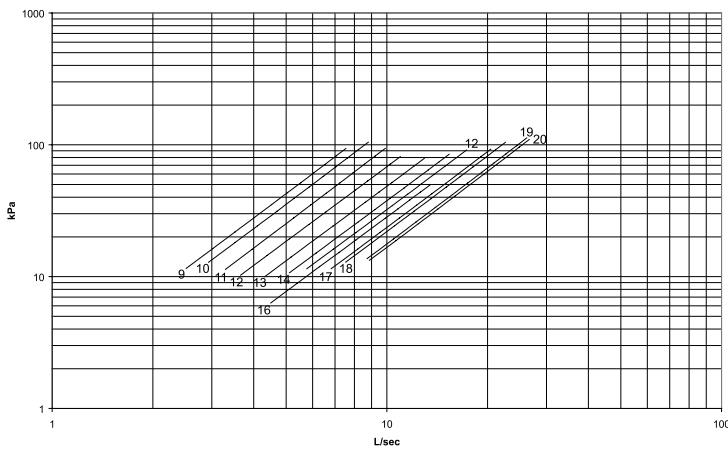

- 9 40 HE CAP 60Hz - 40 HE SQ - 40 HE CP - 40 SE
- 10 46 SE
- 11 40 HE CAP - 46 HE - 52 SE
- 12 52 HE - 60 HE
- 13 60 HE - 70 SE
- 14 80 SE
- 15 80 HE CAP 60Hz - 80 SE SQ - 80 HE CP - 90 SE
- 16 70 HE - 80 HE CAP
- 17 100 SE - 110 SE
- 18 90 HE - 110 SE
- 19 100 HE - 110 HE CAP - 140 SE CAP - 110 HE CAP 60Hz - 110 HE SQ - 110 HE CP - 120 HE
- 20 140 SE SQ - 140 SE CP - 130 HE - 140 HE - 150 HE - 160 HE - 150 SE - 160 SE - 170 SE

Figure 18 - Pressure drops through the strainer

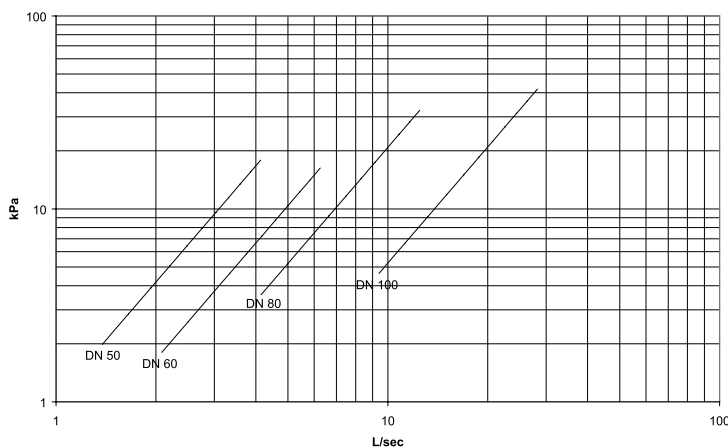

Water pressure drops

Figure 19 - Available pressure - S coil configuration - Standard head

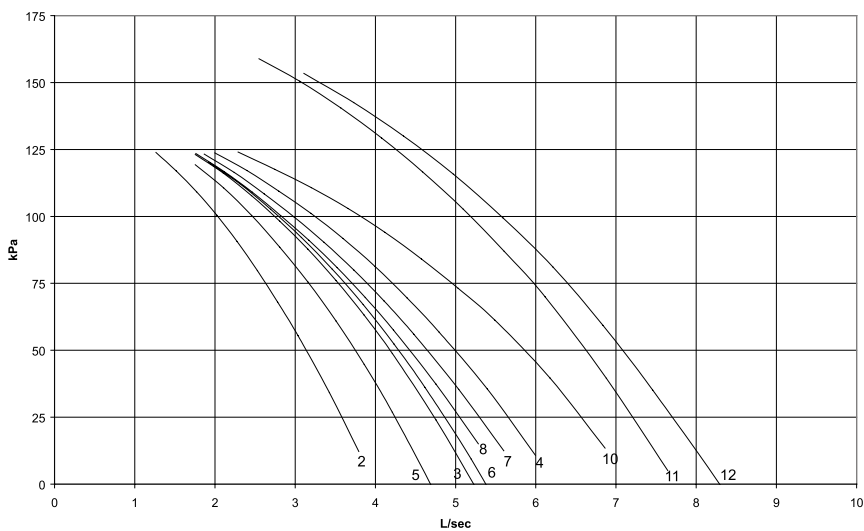

- 2 20 SE - 23 SE - 26 SE SQ - 26 SE CP
 - 3 26 HE SQ - 26 HE CP
 - 4 30 HE SQ - 30 HE CP
 - 5 20 HE - 23 HE SQ - 23 HE CP - 26 SE CAP - 26 HE CAP
 - 6 30 HE CAP
 - 7 30 SE SQ - 30 SE CP - 35 SE SQ - 35 SE CP
 - 8 30 SE CAP
 - 10 35 HE SQ - 35 HE CP
 - 11 35 SE CAP - 39 SE - 45 SE
 - 12 50 SE
- SQ Super quiet
CP Compact
CAP Comprehensive Acoustic Package

Figure 20 - Available pressure - S coil configuration - High head

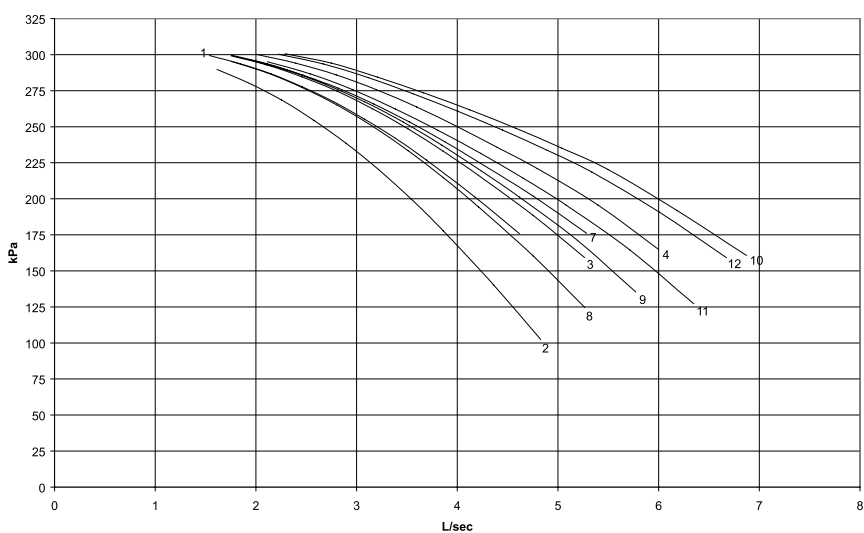

- 1 20 HE SQ - 20 HE CP - 20 HE CAP - 23 HE SQ - 23 HE CP
 - 2 20 SE - 23 SE - 26 SE SQ - 26 SE CP - 26 SE CAP
 - 3 26 HE SQ - 26 HE CP - 23 HE CAP
 - 4 30 HE SQ - 30 HE CP
 - 7 30 SE CAP
 - 8 26 HE CAP
 - 9 30 HE CAP
 - 10 35 HE SQ - 35 HE CP
 - 11 35 SE SQ - 35 SE CP - 30 SE SQ - 30 SE CP
 - 12 35 HE CAP - 35 SE CAP - 39 SE - 45 SE - 50 SE
- SQ Super quiet
CP Compact
CAP Comprehensive Acoustic Package

Water pressure drops

Figure 21 - Available pressure - V and W coil configurations - Standard head

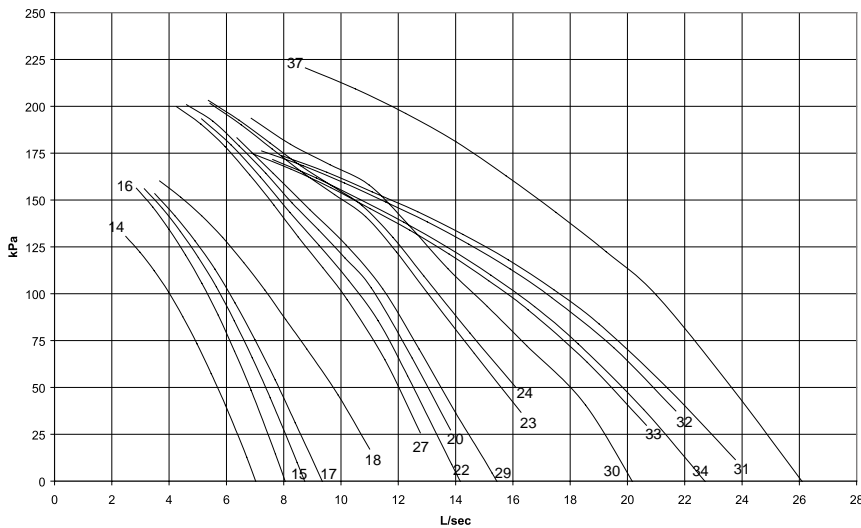

- 14 40 HE SQ - 40 HE CP - 40 SE - 40 SE CAP
- 15 46 HE - 52 SE
- 16 46 SE
- 17 52 HE
- 18 60 SE
- 20 70 HE
- 22 80 SE
- 23 80 HE SQ - 80 HE CP
- 24 80 HE CAP
- 27 60HE - 70 SE - 90 SE CAP
- 29 100 SE SQ - 100 SE CP
- 30 100 HE
- 31 110 HE SQ - 110 HE CP - 120 HE
- 32 110 HE CAP
- 33 90 HE - 90 SE SQ - 90 SE CP - 110 SE - 100 SE CAP
- 34 120 SE
- 37 140 HE - 150 HE - 160 HE - 150 SE - 160 SE
- 170 SE140 SE SQ - 140 SE CP - 140 SE CAP
- SQ Super quiet
- CP Compact
- CAP Comprehensive Acoustic Package

Figure 22 - Available pressure - V and W coil configurations - High head

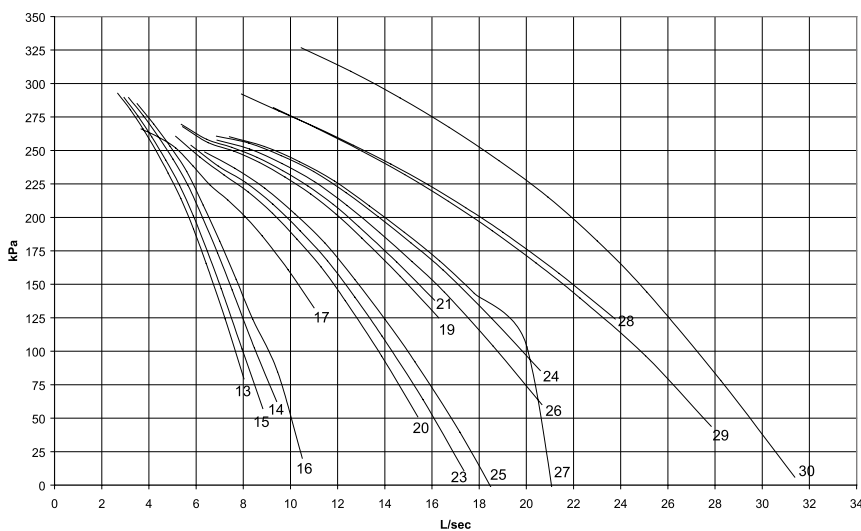

- 13 40 HE SQ - 40 HE CP - 40 SE
- 14 46 HE - 40 HE CAP - 52 SE
- 15 46 SE
- 16 52 HE
- 17 60 SE
- 19 80 HE SQ - 80 HE CP - 90 SE CAP
- 20 80 SE
- 21 80 HE CAP
- 23 90 SE SQ - 90 SE CP - 60 HE - 70 SE
- 24 100 HE - 110 HE CAP
- 25 100 SE SQ - 100 SE CP
- 26 100 SE CAP - 110 SE - 90HE
- 27 110 HE SQ - 110 HE CP
- 28 120 HE - 120 SE
- 29 140 HE - 140 SE SQ - 140 SE CP - 150 HE - 150 SE
- 30 160 HE - 160 SE - 170 HE
- SQ Super quiet
- CP Compact
- CAP Comprehensive Acoustic Package

Operating map

Table 23 - Operating map

Fan cool	Low ambient	Standard ambient	High ambient
Min. outdoor air temperature	-18°C	+7°C	+7°C
Max. outdoor air temperature	+46°C	+46°C	+52°C
Min. leaving water temperature	-12°C	-12°C	-12°C
Max. leaving water temperature	+20°C	+20°C	+20°C

Figure 23 - Operating map

- 1 High ambient (option for high efficiency units only)
- 2 Low ambient (option)
- 3 Standard ambient

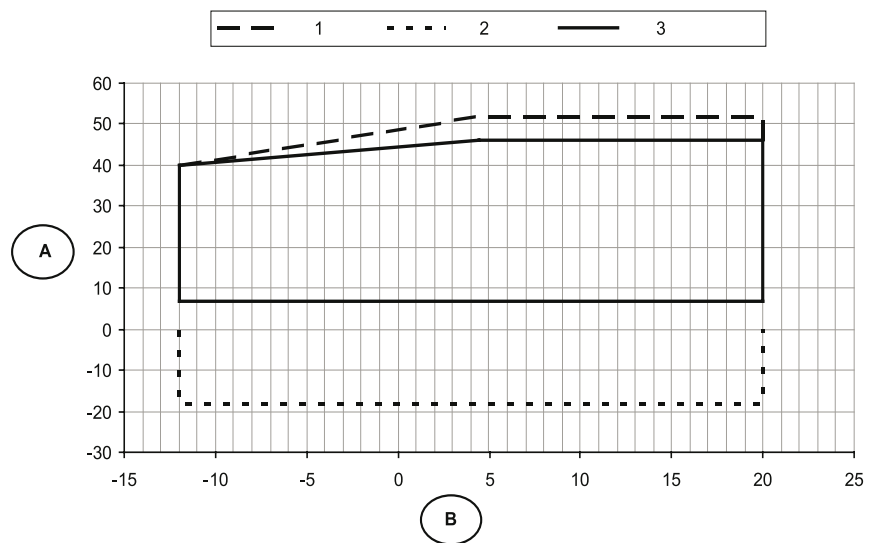

- A Ambient air temperature (°C)
- B Leaving air temperature (°C)

Installation – Electrical

General Recommendations

All wiring must comply with local codes and regulations. Typical field wiring diagrams are included at the end of the manual. Minimum circuit ampacities and other unit electrical data are on the unit nameplate. See the unit order specifications for actual electrical data. Specific electrical schematics and connection diagrams are shipped with the unit.

WARNING Hazardous Voltage!

Disconnect all electric power, including remote disconnects before servicing. Follow proper lockout/tagout procedures to ensure the power can not be inadvertently energized. Failure to disconnect power before servicing could result in death or serious injury.

CAUTION Use Copper Conductors Only!

Unit terminals are not designed to accept other types of conductors. Failure to use copper conductors may result in equipment damage.

Important!

Do not allow conduit to interfere with other components, structural members or equipment. Control voltage (115V) wiring in conduit must be separate from conduit carrying low voltage (<30V) wiring. To prevent control malfunctions, do not run low voltage wiring (<30V) in conduit with conductors carrying more than 30 volts.

Soft starter recommended settings

Acceleration time: 0.5 second speed

Start-up torque: 50%

Deceleration time: 0 second

CAUTION!

Inverters are equipped with integrated filters. They are not compatible with insulated neutral load earthing arrangements.

Pump / fan inverter – power factor correction capacity

WARNING! High voltage!

Any contact with electric components, even after the unit has been switched off, can cause serious injury or death.

Wait at least 4 minutes after switching off the unit, until the current dissipates.

Grounding

Note the fan speed inverter has a high leakage current. Be sure to ground the unit and take this into account when installing the differential protection device.

When running, this unit generates leakage current of over 100 mA.

Installer-Supplied Components

Customer wiring interface connections are shown in the electrical schematics and connection diagrams that are shipped with the unit. The installer must provide the following components if not ordered with the unit:

- Power supply wiring (in conduit) for all field-wired connections.
- All control (interconnecting) wiring (in conduit) for field supplied devices.
- Circuit breakers.

Power Supply Wiring

WARNING Ground Wire!

All field-installed wiring must be completed by qualified personnel. All field-installed wiring must comply with local codes and regulations. Failure to follow this instruction could result in death or serious injuries.

All power supply wiring must be sized and selected accordingly by the project engineer in accordance with local codes and regulations.

WARNING Hazardous Voltage!

Disconnect all electric power, including remote disconnects before servicing. Follow proper lockout/tagout procedures to ensure the power can not be inadvertently energized. Failure to disconnect

power before servicing could result in death or serious injury.

All wiring must comply with local codes and regulations. The installing (or electrical) contractor must provide and install the system interconnecting wiring, as well as the power supply wiring. It must be properly sized and equipped with the appropriate fused disconnect switches. The type and installation location(s) of the fused disconnects must comply with all applicable codes.

Knock-outs for wiring are located on the bottom right side of the control panel. The wiring is passed through these conduits and connected to the disconnect switch.

To provide proper phasing of 3-phase input, make connections as shown in field wiring diagrams and as stated on the WARNING label in the starter panel. For additional information on proper phasing, refer to "Unit Voltage Phasing." Proper equipment ground must be provided to each ground connection in the panel (one for each customer-supplied conductor per phase).

High voltage field-provided connections (are made through knockouts on the right side of the panel.

Figure 24 - Power Entrance

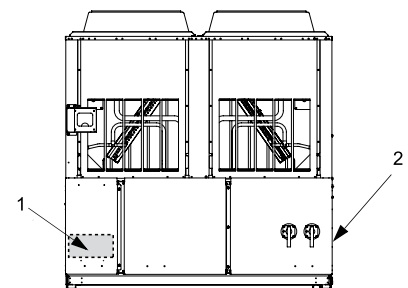

1 = Low voltage power
2 = Incoming power

Installation – Electrical

Control Power Supply

The unit is equipped with a control power transformer; it is not necessary to provide additional control power voltage to the unit. No other loads should be connected to the control power transformer.

All units are factory-connected for appropriate labeled voltages.

Interconnecting Wiring

Chilled Water Pump Control

An evaporator water pump output relay closes when the chiller is given a signal to go into the Auto mode of operation from any source. The contact is opened to turn off the pump in the event of most machine level diagnostics to prevent the build up of pump heat.

The relay output from 1A9 is required to operate the Evaporator Water Pump (EWP) contactor. Contacts should be compatible with 115/240 VAC control circuit. Normally, the EWP relay follows the AUTO mode of the chiller. Whenever the chiller has no diagnostics and is in the AUTO mode, regardless of where the auto command is coming from, the normally open relay is energized. When the chiller exits the AUTO mode, the relay is timed open for an adjustable (using TechView) 0 to 30 minutes. The non- AUTO modes in which the pump is stopped, include Reset, Stop, External Stop, Remote Display Stop, Stopped by Tracer, Start Inhibited by Low Ambient Temp, and Ice Building complete .

Regardless of whether the chiller is allowed to control the pump on a full-time basis, if the MP calls for a pump to start and water does not flow, the evaporator may be damaged catastrophically. It is the responsibility of the installing contractor and/or the customer to ensure that a pump will start when called upon by the chiller controls.

Table 24 - Pump relay operation

Chiller mode	Relay operation
Auto	Instant close
Ice building	Instant close
Tracer override	Close
Stop	Timed open
Ice complete	Instant open
Diagnostics	Instant open

When going from Stop to Auto, the EWP relay is energized immediately. If evaporator water flow is not established in 4 minutes and 15 sec., the CH530 de-energizes the EWP relay and generates a non-latching diagnostic. If flow returns (e.g. someone else is controlling the pump), the diagnostic is cleared, the EWP is re-energized, and normal control resumed.

If evaporator water flow is lost once it had been established, the EWP relay remains energized and a nonlatching diagnostic is generated. If flow returns, the diagnostic is cleared and the chiller returns to normal operation.

In general, when there is either a non-latching or latching diagnostic, the EWP relay is turned off as though there was a zero time delay. Exceptions (see above table) whereby the relay continues to be energized occur with:

A Low Chilled Water Temp. diagnostic (non-latching) (unless also accompanied by an Evap Leaving Water Temperature Sensor Diagnostic)

or

A starter contactor interrupt failure diagnostic, in which a compressor continues to draw current even after commanded to have shutdown

or

A Loss of Evaporator Water Flow diagnostic (non-latching) and the unit is in the AUTO mode, after initially having proven evaporator water flow.

Alarm and Status Relay Outputs (Programmable Relays)

A programmable relay concept provides for enunciation of certain events or states of the chiller, selected from a list of likely needs, while only using four physical output relays, as shown in the field wiring diagram. The four relays are provided (generally with a Quad Relay Output LLID) as part of the Alarm

Relay Output Option. The relay's contacts are isolated Form C (SPDT), suitable for use with 120 VAC circuits drawing up to 2.8 amps inductive, 7.2 amps resistive, or 1/3 HP and for 240 VAC circuits drawing up to 0.5 amp resistive.

The list of events/states that can be assigned to the programmable relays can be found in the following table. The relay will be energized when the event/state occurs.

Installation – Electrical

Table 25 - Alarm and Status Relay Output Configuration Table

	Description
Alarm - Latching	This output is true whenever there is any active diagnostic that requires a manual reset to clear, that affects the Chiller, the Circuit, or any of the Compressors on a circuit. This classification does not include informational diagnostics.
Alarm - Auto Reset	This output is true whenever there is any active diagnostic that could automatically clear, that affects the Chiller, the Circuit, or any of the Compressors on a circuit. This classification does not include informational diagnostics.
Alarm	This output is true whenever there is any diagnostic affecting any component, whether latching or automatically clearing. This classification does not include informational diagnostics
Alarm Ckt 1	This output is true whenever there is any diagnostic effecting Refrigerant Circuit 1, whether latching or automatically clearing, including diagnostics affecting the entire chiller. This classification does not include informational diagnostics.
Alarm Ckt 2	This output is true whenever there is any diagnostic affecting Refrigerant Circuit 2 whether latching or automatically clearing, including diagnostics affecting the entire chiller. This classification does not include informational diagnostics.
Chiller Limit Mode (with a 20 minute filter)	This output is true whenever the chiller has been running in one of the Unloading types of limit modes (Condenser, Evaporator, Current Limit or Phase Imbalance Limit) continuously for the last 20 minutes.
Circuit 1 Running	This output is true whenever any compressors are running (or commanded to be running) on Refrigerant Circuit 1, and false when no compressors are commanded to be running on that circuit.
Circuit 2 Running	This output is true whenever any compressors are running (or commanded to be running) on Refrigerant Circuit 2, and false when no compressors are commanded to be running on that circuit.
Chiller Running	This output is true whenever any compressors are running (or commanded to be running) on the chiller and false when no compressors are commanded to be running on the chiller.
Maximum Capacity	This output is true whenever the chiller has all compressors on. The output is false once one compressor is shut off.
Ice Building Status	The output is true if the unit is configured for ice building, the ice building feature is enabled, there are no ice building diagnostics, and ice building has been commanded. If the unit is not running and is then commanded into ice mode, the output should turn on <u>before</u> the first compressor starts. The output should false when the ice building cycle is complete. This output may be used to interlock with valves, etc. that need to be switched over to do the ice building cycle.
Heat/Cool	The output is true if capacity control is in Hot Water Control mode (the water temperature is being controlled to the Active Hot Water Setpoint). The output is false in any other capacity control mode (Chilled Water Control, Ice Building, etc.).

Installation – Electrical

Relay Assignments Using TechView

CH530 Service Tool (TechView) is used to install the Alarm and Status Relay Option package and assign any of the above list of events or status to each of the four relays provided with the option. The relays to be programmed are referred to by the relay's terminal numbers on the LLID board 1A18.

The default assignments for the four available relays of the CGAM Alarm and Status Package Option are:

Table 26 - Default assignments

Relay	
Relay 1 Terminals J2 – 12,11,10:	Compressor running
Relay 2 Terminals J2 – 9,8,7:	Latching alarm
Relay 3 Terminals J2 – 6,5,4:	Chiller limit
Relay 4 Terminals J2 – 3,2,1:	Alarm

If any of the Alarm/Status relays are used, provide electrical power, 115 VAC with fused-disconnect to the panel and wire through the appropriate relays (terminals on 1A18. Provide wiring (switched hot, neutral, and ground connections) to the remote annunciation devices. Do not use power from the chiller's control panel transformer to power these remote devices. Refer to the field diagrams which are shipped with the unit.

Low Voltage Wiring

WARNING Ground Wire!

All field-installed wiring must be completed by qualified personnel. All field-installed wiring must comply with local codes and regulations. Failure to follow this instruction could result in death or serious injuries.

The remote devices described below require low voltage wiring. All wiring to and from these remote input devices to the Control Panel must be made with shielded, twisted pair conductors. Be sure to ground the shielding only at the panel.

Note: To prevent control malfunctions, do not run low voltage wiring (<30 V) in conduit with conductors carrying more than 30 volts.

Emergency Stop

CH530 provides auxiliary control for a customer specified/installed latching trip out. When this customer-supplied remote contact 6S2 is provided, the chiller will run normally when the contact is closed. When the contact opens, the unit will trip on a manually resettable diagnostic. This condition requires manual reset at the chiller switch on the front of the control panel.

Connect low voltage leads to terminal strip locations on 1A13, J2-3 and 4. Refer to the field diagrams that are shipped with the unit. Silver or gold-plated contacts are recommended. These customer-supplied contacts must be compatible with 24 VDC, 12 mA resistive load.

External Auto/Stop

If the unit requires the external Auto/Stop function, the installer must provide leads from the remote contacts 6S1 to the proper terminals on 1A13 J2-1 and 2.

The chiller will run normally when the contacts are closed. When the contact opens, the compressor(s), if operating, will go to the RUN:UNLOAD operating mode and cycle off. Unit operation will be inhibited. Closure of the contacts will permit the unit to return to normal operation. Field-supplied contacts for all low voltage connections must be compatible with dry circuit 24 VDC for a 12 mA resistive load. Refer to the field diagrams that are shipped with the unit.

Installation – Electrical

Ice Building Option

CH530 provides auxiliary control for a customer specified/installed contact closure for ice building if so configured and enabled. This output is known as the Ice Building Status Relay. The normally open contact will be closed when ice building is in progress and open when ice building has been normally terminated either through Ice Termination setpoint being reached or removal of the Ice Building command. This output is for use with the ice storage system equipment or controls (provided by others) to signal the system changes required as the chiller mode changes from “ice building” to “ice complete”.

When contact 6S3 is provided, the chiller will run normally when the contact is open.

CH530 will accept either an isolated contact closure (External Ice Building command) or a Remote Communicated input (Tracer) to initiate and command the Ice Building mode.

CH530 also provides a “Front Panel Ice Termination Setpoint”, settable through TechView, and adjustable from -6.7 to -0.5°C in at least 1°C increments.

When in the Ice Building mode, and the evaporator entering water temperature drops below the ice termination setpoint, the chiller terminates the Ice Building mode and changes to the Ice Building Complete Mode.

CAUTION Evaporator Damage!

Freeze inhibitor must be adequate for the leaving water temperature. Failure to do so may result in damage to system components.

Techview must also be used to enable or disable Ice Machine Control. This setting does not prevent the Tracer from commanding Ice Building mode.

Upon contact closure, the CH530 will initiate an ice building mode, in which the unit runs fully loaded at all times. Ice building shall be terminated either by opening the contact or based on the entering evaporator water temperature. CH530 will not permit the ice building mode to be reentered until the unit has been switched out of ice building mode (open 6S3 contacts) and then switched back into ice building mode (close 6S3 contacts.)

In ice building, all limits (freeze avoidance, evaporator, condenser, current) will be ignored. All safeties will be enforced. If, while in ice building mode, the unit gets down to the freeze stat setting (water or refrigerant), the unit will shut down on a manually resettable diagnostic, just as in normal operation.

Connect leads from 6S3 to the proper terminals of 1A16. Refer to the field diagrams which are shipped with the unit. Silver or gold-plated contacts are recommended. These customer-supplied contacts must be compatible with 24 VDC, 12 mA resistive load.

External Chilled Water Setpoint (ECWS) Option

The CH530 provides inputs that accept either 4-20 mA or 2-10 VDC signals to set the external chilled water setpoint (ECWS). This is not a reset function. The input defines the setpoint. This input is primarily used with generic BAS (building automation systems). The chilled water setpoint set via the DynaView or through digital communication with Tracer (Comm3). The arbitration of the various chilled water setpoint sources is described in the flow charts at the end of the section.

The chilled water setpoint may be changed from a remote location by sending either a 2-10 VDC or 4- 20 mA signal to the 1A14, J2-2 and 3. The 2-10 VDC and 4-20 mA each correspond to a 10 to 65°F (-12 to 18°C) external chilled water setpoint.

The following equations apply:

Voltage Signal Current Signal

As generated from external source
 $VDC = 0.1455 * (ECWS) + 0.5454$
 $mA = 0.2909 * (ECWS) + 1.0909$

As processed by CH530
 $ECWS = 6.875 * (VDC) - 3.75$
 $ECWS = 3.4375 * (mA) - 3.75$

If the ECWS input develops an open or short, the LLID will report either a very high or very low value back to the main processor. This will generate an informational diagnostic and the unit will default to using the Front Panel (DynaView) Chilled Water Setpoint.

TechView Service Tool is used to set the input signal type from the factory default of 2-10 VDC to that of 4-20 mA. TechView is also used to install or remove the External Chilled Water Setpoint option as well as a means to enable and disable ECWS.

Installation – Electrical

External Demand Limit Setpoint (EDLS) Option

CH530 provide a means to limit the capacity of the chiller by limiting the number of compressors or stages that are allowed to run. The maximum number of compressor or stages allowed to run can vary from one to the number of stages on the unit. The staging algorithm is free to decide which compressor or stage shall be turned off or prevented from running to meet this requirement.

CH530 shall accept either a 2-10 VDC or 4-20 mA analog input suitable for customer connection to set the unit external demand limit setpoint (EDLS).

2-10 VDC and 4-20 mA shall each correspond to an EDLS range with a minimum of 0% and a maximum of 100%. The following equations exist:

The minimum EDLS will be clamped at the front panel based on 100% / Total number of compressors. For input signals beyond the 2-10VDC or 4-20mA range, the end of range value shall be used. For example, if the customer inputs 21 mA, the EDLS shall limit itself to the corresponding 20 mA EDLS.

ECLS and EDLS Analog Input Signal Wiring Details:

Both the ECWS and EDLS can be connected and setup as either a 2-10 VDC (factory default), 4-20 mA, or resistance input (also a form of 4-20mA) as indicated below. Depending on the type to be used, the TechView Service Tool must be used to configure the LLID and the MP for the proper input type that is being used. This is accomplished by a setting change on the Custom Tab of the Configuration View within TechView.

The J2-3 and J2-6 terminal is chassis grounded and terminal J2-1 and J2-4 can be used to source 12 VDC.

The ECLS uses terminals J2-2 and J2-3. EDLS uses terminals J2-5 and J2-6. Both inputs are only compatible with high-side current sources.

	Voltage signal	Current signal
As generated from external source	$V_{dc} = 8 * (EDLS) + 2$	$mA = 16 * (EDLS) + 4$
As processed by CH530	$EDLS = (V_{ds} - 2) / 8$	$EDLS = (mA - 4) / 16$

Figure 25 - Wiring Examples for ECLS and EDLS

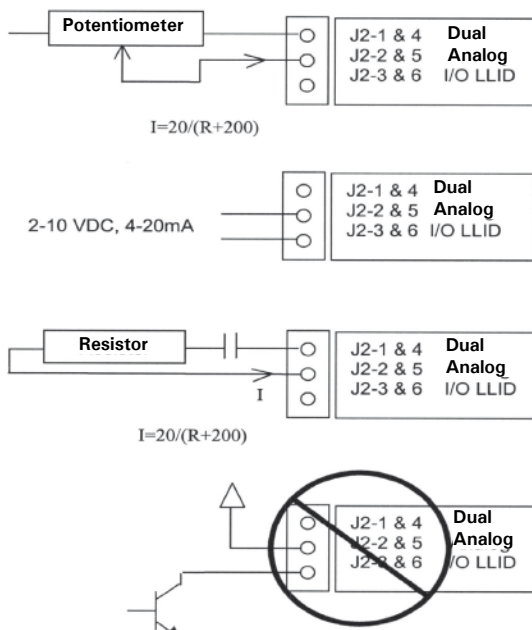

Installation – Electrical

Chilled Water Reset (CWR)

CH530 resets the chilled water temperature setpoint based on either return water temperature, or outdoor air temperature. Return Reset is standard, Outdoor Reset is optional.

The following shall be selectable:

- One of three Reset Types: None, Return Water Temperature Reset, Outdoor Air Temperature Reset, or Constant Return Water Temperature Reset.
- Reset Ratio Setpoints.
- For outdoor air temperature reset there shall be both positive and negative reset ratios.
- Start Reset Setpoints.
- Maximum Reset Setpoints.

The equations for each type of reset are as follows:

Return

$$CWS' = CWS + \text{RATIO} (\text{START RESET} - (\text{TWE} - \text{TWL}))$$

$$\text{and } CWS' > \text{ or } = CWS$$

$$\text{and } CWS' - CWS < \text{ or } = \text{Maximum Reset}$$

Outdoor

$$CWS' = CWS + \text{RATIO} * (\text{START RESET} - \text{TOD})$$

$$\text{and } CWS' > \text{ or } = CWS$$

$$\text{and } CWS' - CWS < \text{ or } = \text{Maximum Reset}$$

where

CWS' is the new chilled water setpoint or the «reset CWS»

CWS is the active chilled water setpoint before any reset has occurred, e.g. normally Front Panel, Tracer,

or ECWS

RESET RATIO is a user adjustable gain

START RESET is a user adjustable reference

TOD is the outdoor temperature

TWE is entering evaporator water temperature

TWL is leaving evaporator water temperature

MAXIMUM RESET is a user adjustable limit providing the maximum amount of reset. For all types of reset, $CWS' - CWS < \text{ or } = \text{Maximum Reset}$.

In addition to Return and Outdoor Reset, the MP provides a menu item for the operator to select a Constant Return Reset. Constant Return Reset will reset the leaving water temperature setpoint so as to provide a constant entering water temperature. The Constant Return Reset equation is the same as the Return Reset equation except on selection of Constant Return Reset, the MP will automatically set Ratio, Start Reset, and Maximum Reset to the following.

$$\text{RATIO} = 100\%$$

$$\text{START RESET} = \text{Design Delta Temp.}$$

$$\text{MAXIMUM RESET} = \text{Design Delta Temp.}$$

The equation for Constant Return is then as follows:

$$CWS' = CWS + 100\% (\text{Design Delta Temp.} - (\text{TWE} - \text{TWL}))$$

$$\text{and } CWS' > \text{ or } = CWS$$

$$\text{and } CWS' - CWS < \text{ or } = \text{Maximum Reset}$$

When any type of CWR is enabled, the MP will step the Active CWS toward the desired CWS' (based on the above equations and setup parameters) at a rate of 1 degree C every 5 minutes until the Active CWS equals the desired CWS'. This applies when the chiller is running.

When the chiller is not running the CWS is reset immediately (within one minute) for Return Reset and at a rate of 1 degree C every 5 minutes for Outdoor Reset. The chiller will start at the Differential to Start value above a fully reset CWS or CWS' for both Return and Outdoor Reset.

Reset type	Reset ratio range	Start reset range	Maximum reset range	Increment SI units	Factory default value
Return	10 – 120%	2.2-16.7°C	0.0-11.1 C	1%	50%
Outdoor	80 to -80%	10-54.4°C	0.0 to 11.1°C	1%	10%

Communications Interface options

Optional Tracer Communications Interface

This option allows the Tracer CH530 controller to exchange information (e.g. operating setpoints and Auto/Standby commands) with a higher-level control device, such as a Tracer Summit or a multiple machine controller. A shielded, twisted pair connection establishes the bi-directional communications link between the Tracer CH530 and the building automation system.

Note: To prevent control malfunctions, do not run low voltage wiring (<30 V) in conduit with conductors carrying more than 30 volts.

WARNING Ground Wire!

All field-installed wiring must be completed by qualified personnel. All field-installed wiring must comply with local codes and regulations. Failure to follow this instruction could result in death or serious injuries.

Field wiring for the communication link must meet the following requirements:

- All wiring must be in accordance with local codes and regulations.
- Communication link wiring must be shielded, twisted pair wiring (Belden 8760 or equivalent). See the table below for wire size selection:

Table 27 - Wire Size

	Wire Size Maximum Length of Communication Wire
2.5 mm ²	1525 m
1.5 mm ²	610 m
1.0 mm ²	305 m

- The communication link cannot pass between buildings.
- All units on the communication link can be connected in a "daisy chain" configuration.

LonTalk Communications Interface for Chillers (LCI-C)

CH530 provides an optional LonTalk Communication Interface (LCI-C) between the chiller and a Building Automation System (BAS). An LCI-C LLID shall be used to provide «gateway» functionality between a LonTalk compatible device and the Chiller. The inputs/outputs include both mandatory and optional network variables as established by the LonMark Functional Chiller Profile 8040.

Installation Recommendations

- 22 AWG Level 4 unshielded communication wire recommended for most LCI-C installations
- LCI-C link limits: 1300m, 60 devices
- Termination resistors are required
- 105 ohms at each end for Level 4 wire
- 82 ohms at each end for Trane «purple» wire
- LCI-C topology should be daisy chain
- Zone sensor communication stubs limited to 8 per link, 15m each (maximum)
- One repeater can be used for an additional 1300m, 60 devices, 8 communication stubs

Communications Interface options

Table 28 - LonTalk Points List

Inputs/Outputs	Length and Contents	SNVT / UNVT
Chiller Enable/Disable Request	2 bytes	SNVT_switch
Chilled Water Setpoint	2 bytes	SNVT_temp_p
Capacity Limit Setpoint (used by Demand Limit Setpoint)	2 bytes	SNVT_lev_percent
Operating Mode Request	1 byte	SNVT_hvac_mode
Chiller Running State	2 bytes	SNVT_switch
Active Chilled Water or Hot Water Setpoint	2 bytes	SNVT_temp_p
Actual Running Capacity	2 bytes	SNVT_lev_percent
Active Capacity Limit Setpoint (from Active Demand Limit Setpoint)	2 bytes	SNVT_lev_percent
Evaporator Leaving Water Temp	2 bytes	SNVT_temp_p
Evaporator Entering Water Temp	2 bytes	SNVT_temp_p
Alarm Description	31 bytes	SNVT_str_asc
Chiller Status	3 bytes	SNVT_chlr_status
00 = Chiller off 01 = Chiller in start mode 02 = Chiller in run mode 03 = Chiller in pre-shutdown mode 04 = Chiller in service mode 03 = Cooling only 0A = Cooling with compressor not running 0B = Ice-making mode bit 0 (MSB) = in alarm mode bit 1 = run enabled bit 2 = local bit 3 = limited bit 4 = evaporator water flow		

Operating principles

This section contains an overview of the operation of CGAM air-cooled liquid chiller equipped with microcomputer-based control systems. It describes the overall operating principles of the CGAM water chiller.

Note: To ensure proper diagnosis and repair, contact a qualified service organization if a problem should occur.

General

The Model CGAM units are scroll compressor(s), single or dual circuit, air-cooled liquid chillers. These units are equipped with unit-mounted starter/control panels and operate with R410A refrigerant.

The basic components of a CGAM unit are:

- Unit-mounted panel containing starter and Tracer CH530 controller and Input/Output LLIDS
- Scroll compressors
- Brazed plate evaporator
- Air-cooled condenser with subcooler
- Electronic expansion valve
- Related interconnecting piping.

Refrigerant Cycle

The refrigeration cycle of the Model CGAM chiller is conceptually similar to other Trane air-cooled chiller products. The CGAM chiller uses a brazed plate evaporator and an air-cooled condenser. The compressors use suction gas cooled motors and an oil management system to provide almost oil-free refrigerant to the condenser and evaporator for maximum heat transfer while lubricating and sealing compressor rotors and bearings. The lubrication system helps to assure long compressor life and contributes to quiet operation.

Refrigerant condenses in the air-cooled heat exchanger is available in three configurations—slant, V and W—based on the CGAM nominal tonnage cooling capacity. Liquid refrigerant is metered into the brazed plate evaporator using an electronic expansion valve to maximize chiller efficiency at full and part load operation.

The CGAM chiller is equipped with a unit-mounted starter and control panel. Microprocessor-based unit control modules (Trane Tracer™ CH530) provide accurate chilled water control and providing monitoring, protection and adaptive limit functions. The adaptive nature of the controls intelligently prevent the chiller from operating outside of its limits, or compensates for unusual operating conditions while keeping the chiller running rather than simply shutting off the chiller. If problems do occur, the CH530 controls provide diagnostic messages to help the operator in troubleshooting.

Operating principles

Figure 26 - CGAM Refrigerant Circuit - W coil configuration

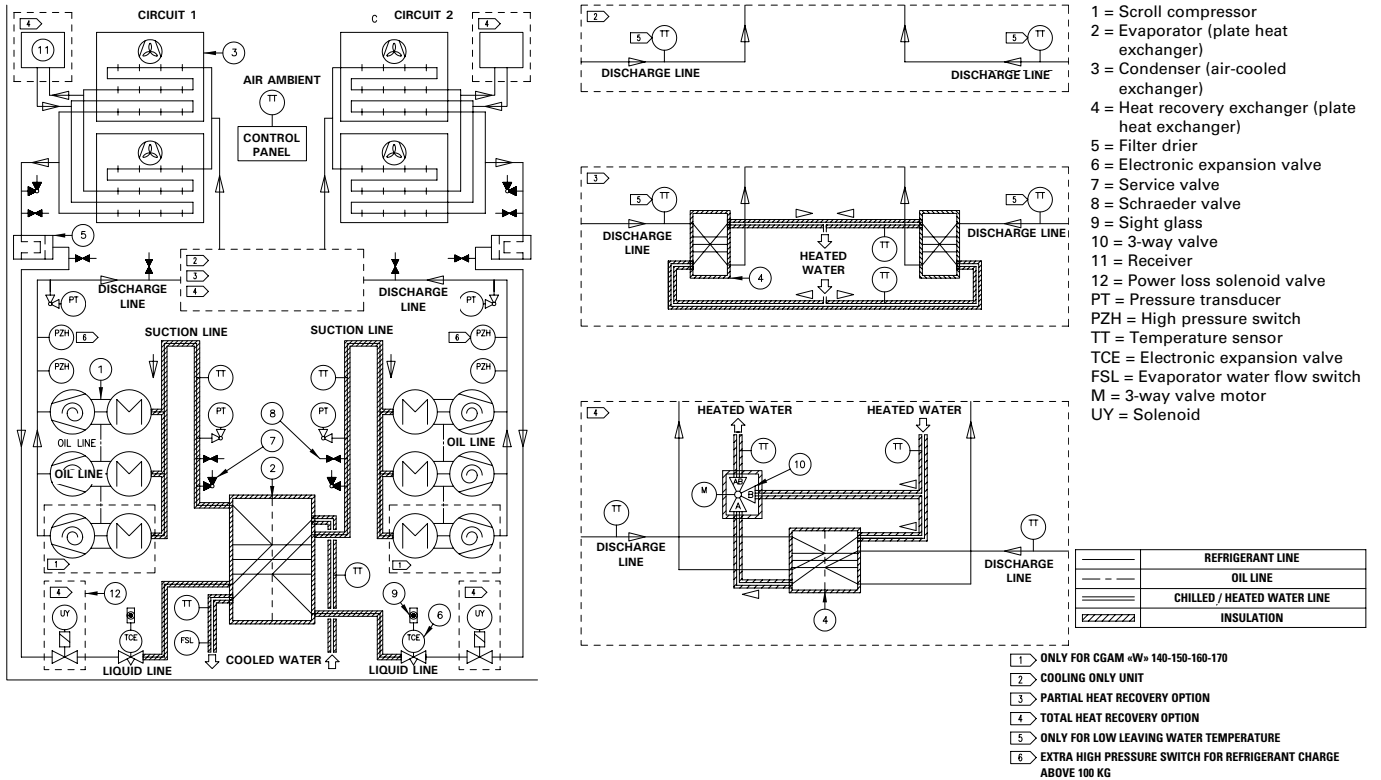
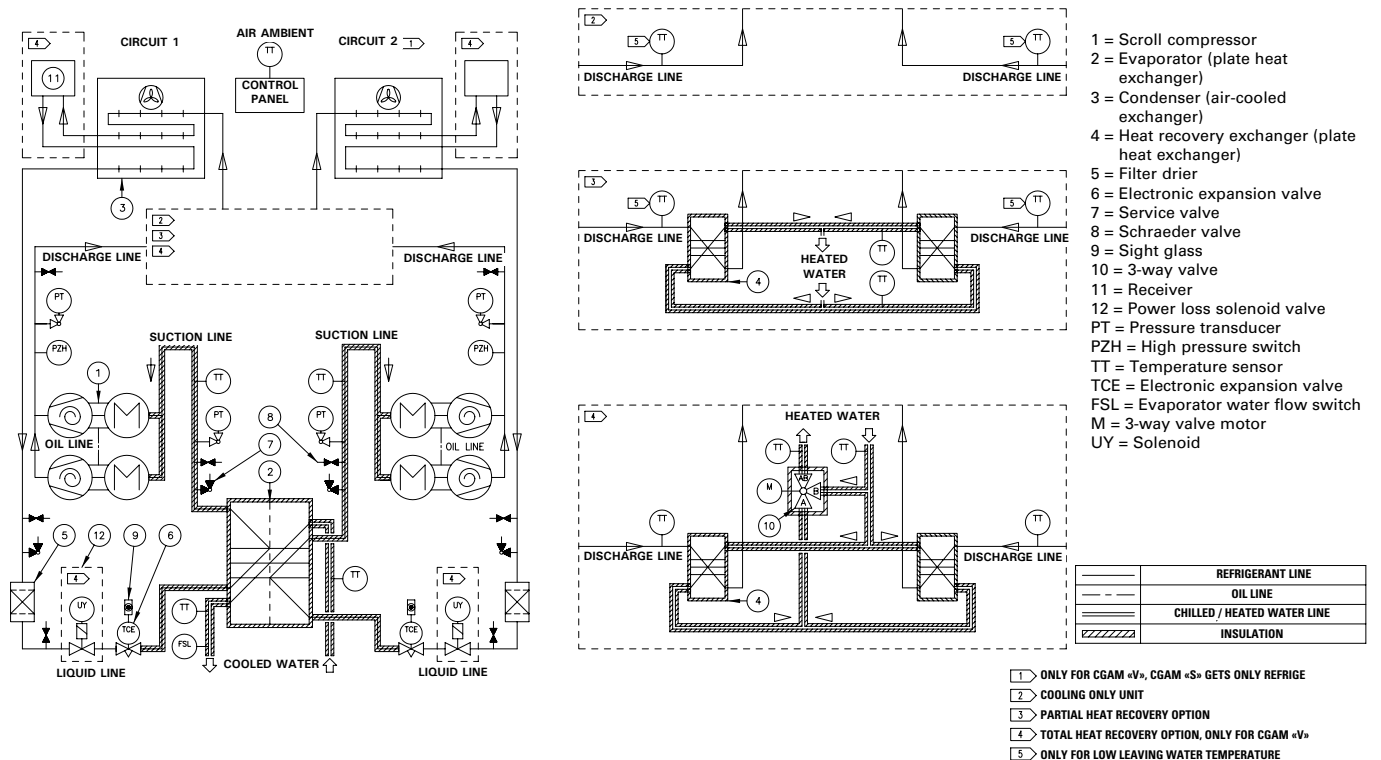
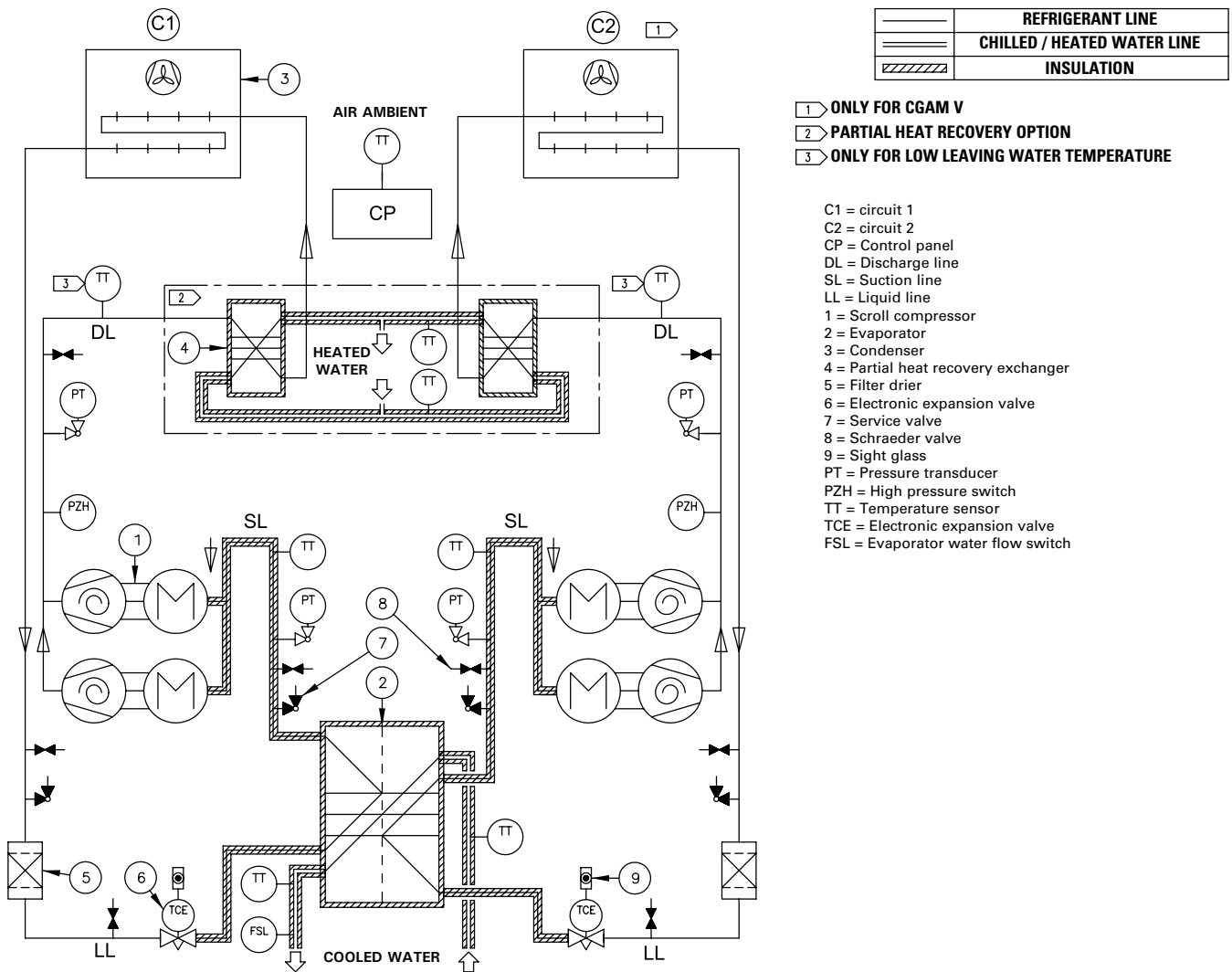

Figure 27 - CGAM Refrigerant Circuit - V coil configuration with THR option



Operating principles

Figure 28 - CGAM Refrigerant Circuit - S and V coil configurations



Operating principles

Oil System

The oil is efficiently separated inside the scroll compressor and will remain in the scroll compressor during all run cycles. Between 1-2% of the oil circulates around with the refrigerant.

See compressor section for oil level information.

Hydraulic module water chart (option)

Figure 29 - Hydraulic module water chart

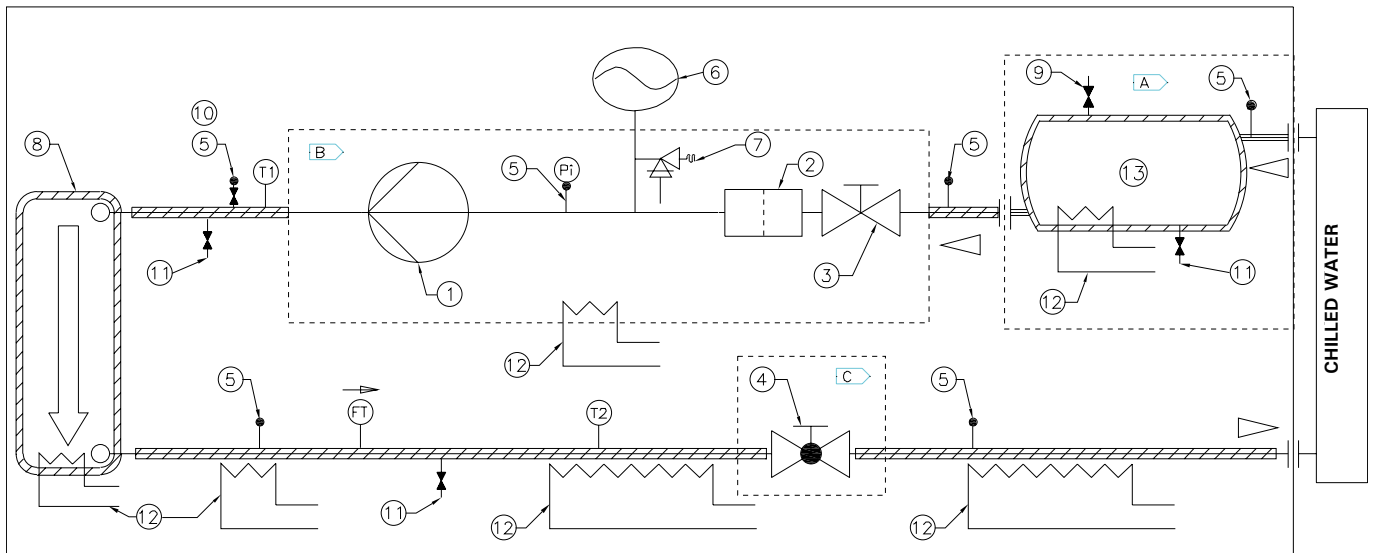

- 1 Single or Dual Pump
 - 2 Optional Water Strainer
 - 3 Shut Off Valve
 - 4 Stop and Balancing Valve
 - 5 Valve for Pressure Point
 - 6 Expansion Tank
 - 7 Water Pressure Point
 - 8 Exchanger
 - 9 Automatic Air Bleed
 - 10 Manual Air Bleed
 - 11 Drain Valve
 - 12 Antifreeze Protection
 - 13 Buffer Tank
- Pi Gauge
 FT Water Flow Switch
 A Optional buffer tankk
 B Pump box
 C Optional balancing valve
 T1 Evap Water Inlet Temp Sensor
 T2 Evap Water Outlet Temp Sensor

— Water Line — Insulated Water Line

Partial Heat Recovery

The partial heat recovery is comprised of an auxiliary heat exchanger installed in the discharge line between the compressor and the air-cooled condenser. The heat exchanger cools compressor discharge gas and rejects the energy to a separate water loop for hot water applications. The chiller can simultaneously produce chilled water and hot water.

The heating capacity is driven by the cooling demand on the chiller, the ambient temperature and the temperature of the heat recovery loop.

The partial heat recovery includes:

- One brazed plate heat exchanger per refrigerant circuit
- Insulation of the heat exchanger(s) and water pipe

- Two temperature sensors to read the inlet/outlet hot water temperature information on the unit control display
- Freeze protection heater (option)
- Manual air vent
- Drain valve

Water circulating inside the heat recovery heat exchanger should never be used for food process or drinking water. It must be used through a direct loop to heat or preheat water.

Note: If the partial heat recovery heat exchanger is drained, the heater must be turned off to avoid damaging the partial heat recovery heat exchanger. The heater should only be on when the heat recovery heat exchanger has water in it.

CAUTION! Discharge gas temperature can reach 130°C, resulting in overheating of the heat recovery water.

Partial heat recovery piping

A field-installed safety or relief valve on the water side is required with the partial heat recovery to prevent risks resulting from a failure of the thermostat.

A 1 to 1.6 mm strainer must be installed close to the partial heat recovery heat exchanger entering water line to protect the heat exchanger.

The partial heat recovery water temperature entering the unit should be at least 40°C.

Insulate water lines and other portions of the heat recovery water loop to prevent heat loss and potential injury due to exposure to a hot surface.

For recommended partial heat recovery piping, see below.

Figure 30 - Partial heat recovery piping recommendations

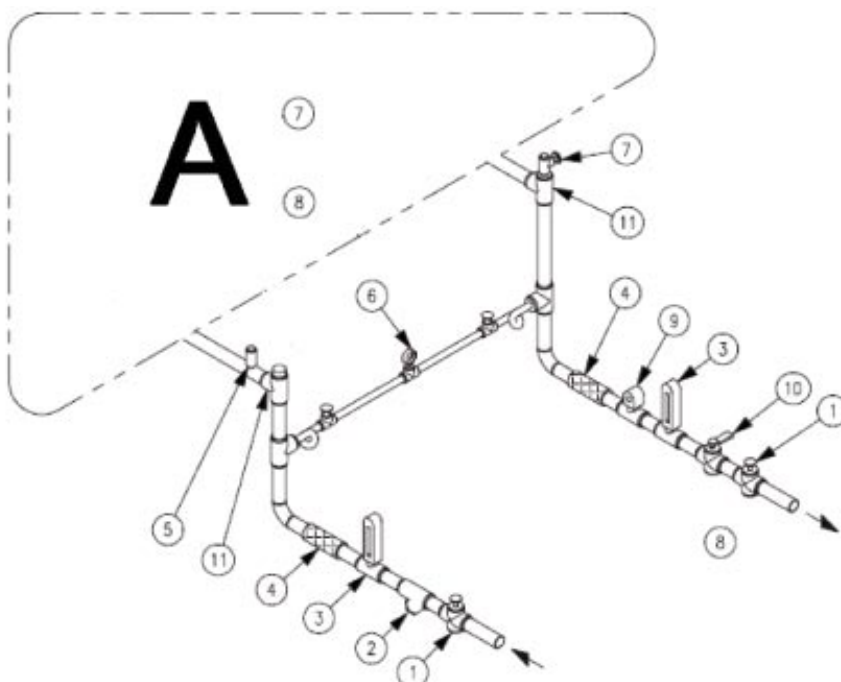

- A = Trane supplied
 1 = Gate valve
 2 = Water strainer
 3 = Thermometer (user option)
 4 = Vibration eliminator
 5 = Relief valve
 6 = Valved pressure gauge
 7 = Vent (one factory-installed)
 8 = Drain (at lowest position)
 9 = Flow switch (warm water flow)
 10 = Balancing valve
 11 = Clean out tee

Partial Heat Recovery

Do not use untreated or improperly treated water in the heat recovery water loop since it will cause inefficient operation and potential damage to the unit such as: reduced heat transfer between water and refrigerant, increased water pressure drop and reduced water flow.

CAUTION!: Proper Water Treatment!

The use of untreated or improperly treated water in a chiller may result in scaling, erosion, corrosion, algae, or slime. It is recommended that the services of a qualified water treatment specialist be engaged to determine what water treatment, if any, is required. Trane assumes no responsibility for equipment failures which result from untreated or improperly treated water, or saline or brackish water.

Partial heat recovery freeze protection (option)

The heat recovery condenser is insulated and a factory-installed heater is installed and will protect the heat exchanger from freezing in ambient temperatures down to -18°C. When the ambient temperature drops to approximately 5°C, the main controller energizes the heaters.

Note: The inlet and outlet piping should be protected against freezing by one of the following methods:

- Install heat tape on all field-installed water piping.
- Add freeze inhibit fluid to the partial heat recovery water loop.

Total Heat Recovery

The total heat recovery option includes:

- A braze plate heat exchanger installed in series with the air-cooled condenser (two single circuit exchangers on V units and one dual circuit exchanger on W units)
- A liquid receiver to stock the liquid refrigerant leaving the air-cooled condenser
- A 3-way valve factory installed on the water side to manage the entering water temperature
- Insulation of the heat exchanger, 3-way valve and water pipe
- Two temperature sensors for inlet and outlet hot water temperature control
- Two temperature sensors for compressor discharge temperature monitoring
- Freeze protection heaters (option)
- Manual air vent
- Drain valve
- Additional High Pressure Cut out for some of the largest unit sizes
- Top bearing heater for low ambient application
- Liquid line solenoid valve to protect the compressor in case of power loss
- variable fan drives

The heat exchanger is used both as a desuperheater and a condenser of compressors discharge gas. Refrigerant leaves the total heat recovery braze plates heat exchanger as a mixture of gas and liquid. The air-cooled condenser is used to finalize the condensation and provide a subcooled refrigerant to the expansion valve.

The chiller can simultaneously produce chilled water and hot water. When there is no water through the total heat recovery, its heat exchanger operates as a simple pressure drop generator.

The heating capacity is driven by the cooling demand on the chiller, the ambient temperature and the temperature of the heat recovery loop. The heating capacity is optimized by a smart control of the condensing temperature using the fans.

Water circulating inside the heat recovery heat exchanger should never be used in food processing or as drinking water. It must be used through a direct loop to heat or preheat water.

Note: If the total heat recovery heat exchanger is drained, the heater must be turned off to avoid damaging the total heat recovery heat exchanger. The heater should only be on when the heat recovery heat exchanger has water in it.

CAUTION! Discharge gas temperature can reach 130°C, resulting in overheating of the heat recovery water.

CAUTION! For the first start, Total Heat Recovery water temperature sensors should be checked to make sure that they are not reversed.

CAUTION! A field-installed safety or relief valve on the water side is required with the total heat recovery to prevent risks resulting from a failure of the unit control.

Total Heat Recovery

Piping recommendations

A 1 to 1.6 mm strainer must be installed close to the total heat recovery heat exchanger entering water line to protect the heat exchanger.

Insulate water lines and other portions of the heat recovery water loop to prevent heat loss and potential injury due to exposure to a hot surface.

Figure 31 - Total heat recovery pipe recommendations

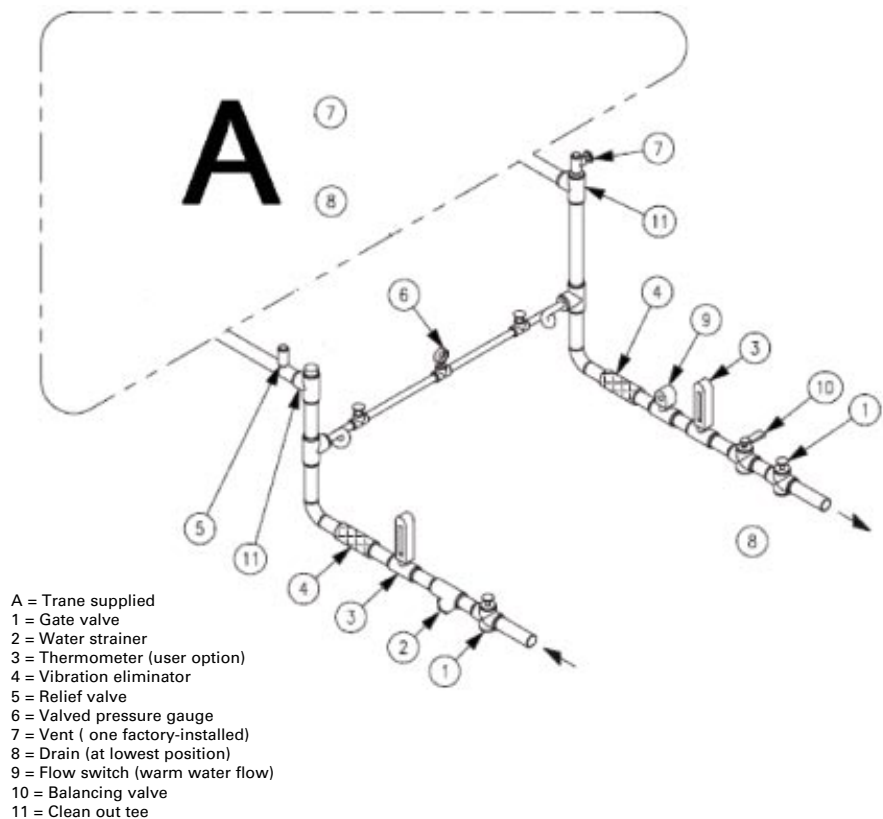

Do not use untreated or improperly treated water in the heat recovery water loop since it will cause inefficient operation and potential damage to the unit such as: reduced heat transfer between water and refrigerant, increased water pressure drop and reduced water flow.

CAUTION!: Proper Water Treatment! The use of untreated or improperly treated water in a chiller may result in scaling, erosion, corrosion, algae, or slime. It is recommended that the services of a qualified water treatment specialist be engaged to determine what water treatment, if any, is required. Trane assumes no responsibility for equipment failures which result from untreated or improperly treated water, or saline or brackish water.

Total Heat Recovery

Freeze protection (option)

The heat recovery condenser is insulated and a factory-installed heater is installed and will protect the heat exchanger from freezing in ambient temperatures down to -18°C. When the ambient temperature drops to approximately 5°C, the main controller energizes the heaters.

Note: The inlet and outlet piping should be protected against freezing by one of the following methods:

- Install heat tape on all field installed water piping.
- Add freeze inhibit fluid to the total heat recovery water loop.

Operating map

Application	Standard ambient	High ambient
	(°C)	(°C)
Min. outdoor air temperature	7.2	7.2
Max. outdoor air temperature	46	52
Min. leaving evaporator water temperature	4.4	4.4
Max. leaving evaporator water temperature	15.6	15.6
Min. leaving THR water temperature	30	30
Max. leaving THR water temperature	60	60

THR should not be used for glycol application on evaporator side.

Minimum THR start-up water temperature should be higher than 5°C.

THR should be used when leaving evaporator temperature is between 5 and 15.5°C.

Total Heat Recovery Operation Map

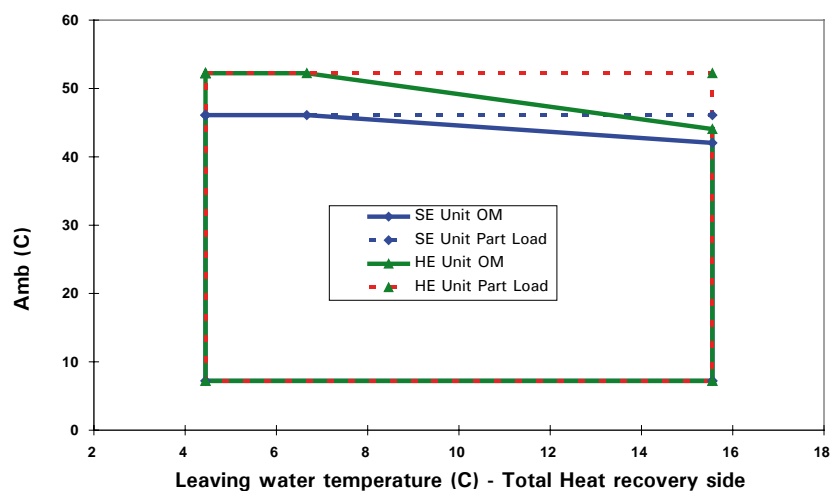

Total Heat Recovery

Total Heat Recovery Operation Map

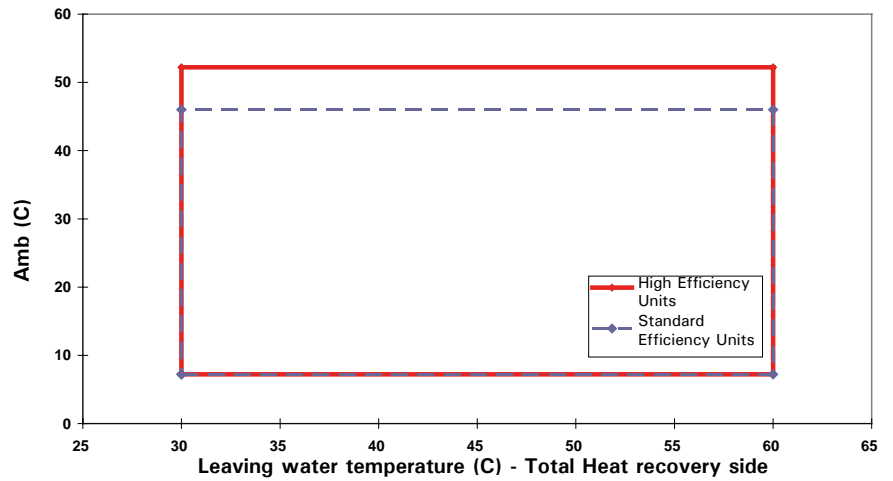

Total heat recovery – water loop pressure drop

THR WPD Curve

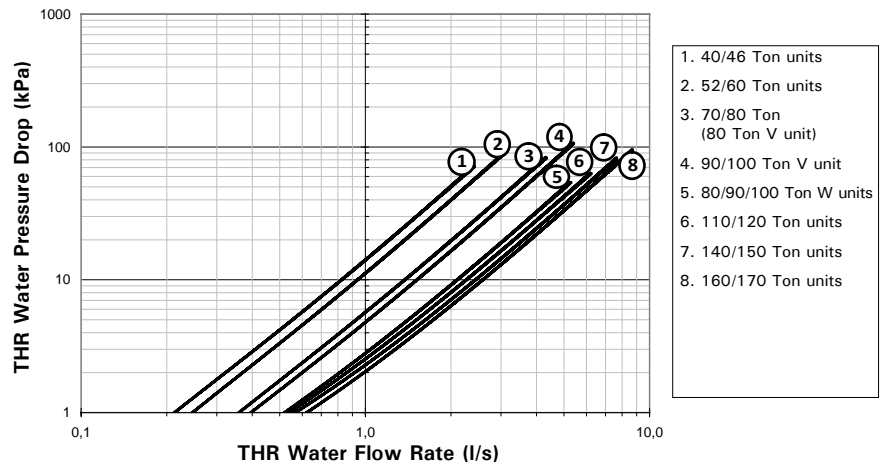

Total Heat Recovery

THR BP WPD Curve

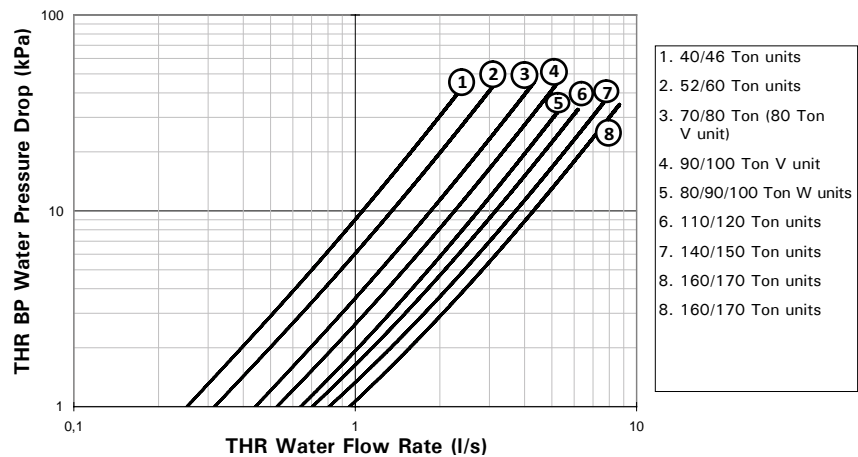

THR 3-way valve description

The 3-way valve is divided into 2 main parts: the actuator and the valve body.

Valve body

3 types of valve are used (DN32, DN40, DN50) with a Kvs respectively of 16, 25, 40.

Kvs –value is showing the capacity of media flow of a valve, it characterizes the volume flow (m³/h) of water by measuring a differential pressure (bar). This value is related to full stroke.

The 3-way valve body is connected to the system in 3 points A, B, AB as below:

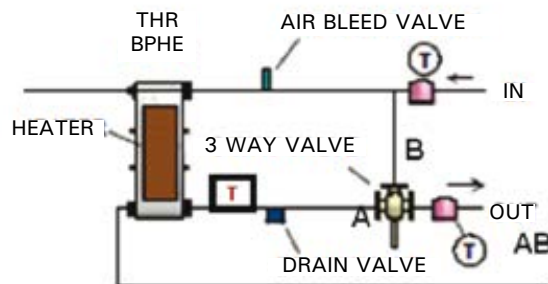

Total Heat Recovery

Actuator overview

- Supply voltage: 24 Vac
- Actuator setting
- W1(input signal failure): 100%, actuator will adjust to 100% position when signal input fails (THR BP bypassed)
- W2(input signal range): LED "OFF" for 2~10V
- W3 (direction of action): LED "ON" 2V for A-AB close, 10V for A-AB full open

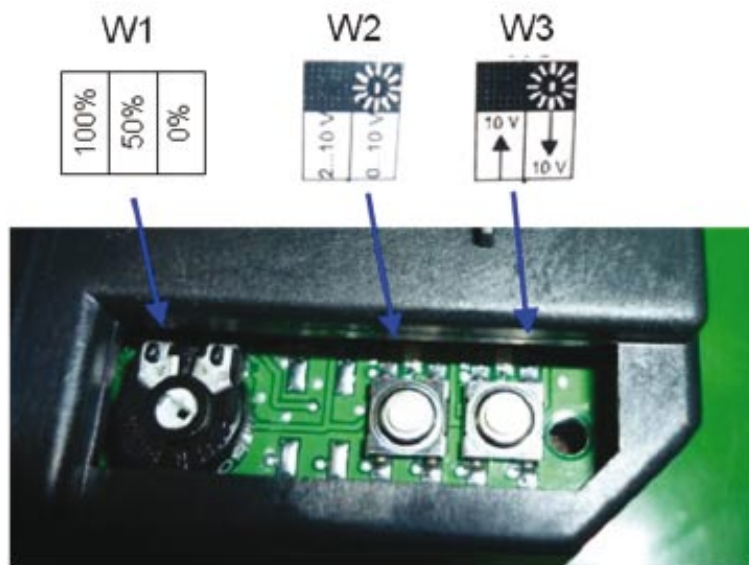

Refrigerant charge

When a total heat recovery is installed, refrigerant charge (kg) are as shown in the table below.

Number of Circuits	Size (Ton)	High Efficiency - Super quiet	High Efficiency - Compact	Standard Efficiency - Super quiet	Standard Efficiency - Compact
2	40	28	28	24	24
2	46	27	27	26	26
2	52	27	27	26	26
2	60	40	40	29	29
2	70	40	41	31	31
2	80	64	64	38	38
2	90	65	63	39	40
2	100	73	73	41	42
2	110	75	74	55	57
2	120	73	73	63	63
2	130				
2	140	99	99	76	77
2	150	111	112	75	76
2	160	113	113	78	78
2	170			97	99

Controls Interface

CH530 Communications

Overview

The Trane CH530 control system that runs the chiller consists of several elements:

- The main processor collects data, status, and diagnostic information and communicates commands to the starter module and the LLID (for Low Level Intelligent Device) bus. The main processor has an integral display (DynaView).
- Low level intelligent device (LLID) bus. The main processor communicates to each input and output device (e.g. temperature and pressure sensors, low voltage binary inputs, analog input/output) all connected to a four-wire bus, rather than the conventional control architecture of signal wires for each device.
- The communication interface to a building automation system (BAS).
- A service tool to provide all service/maintenance capabilities.

Main processor and service tool (TechView) software is downloadable from www.trane.com.

The process is discussed later in this section under TechView Interface. DynaView provides bus management. It has the task of restarting the link, or filling in for what it sees as “missing” devices when normal communications has been degraded. Use of TechView may be required.

The CH530 uses the IPC3 protocol based on RS485 signal technology and communicating at 19.2 Kbaud to allow 3 rounds of data per second on a 64-device network. A typical four-compressor CGAM will have around 30 devices.

Most diagnostics are handled by the DynaView. If a temperature or pressure is reported out of range by a LLID, the DynaView processes this information and calls out the diagnostic. The individual LLIDs are not responsible for any diagnostic functions.

Note: It is imperative that the CH530 Service Tool (TechView) be used to facilitate the replacement of any LLID or reconfigure any chiller component. TechView is discussed later in this section.

Controls Interface

Each chiller is equipped with a DynaView interface. The DynaView has the capability to display information to the operator including the ability to adjust settings. Multiple screens are available and text is presented in multiple languages as factory-ordered or can be easily downloaded from www.trane.com.

TechView can be connected to either the DynaView module and provides further data, adjustment capabilities, diagnostics information using downloadable software.

More information on DynaView and TechView is available in the CGAM control user guide.

Pre-Start Checkout

When installation is complete, but prior to putting the unit into service, the following pre-start procedures must be reviewed and verified correct:

WARNING Hazardous Voltage!

Disconnect all electric power, including remote disconnects before servicing. Follow proper lockout/tagout procedures to ensure the power can not be inadvertently energized. Failure to disconnect power before servicing could result in death or serious injury

- Inspect all wiring connections to be sure they are clean and tight.
- Verify that all refrigerant valves are "OPEN"
- Check the power supply voltage to the unit at the main power fused-disconnect switch. Voltage must be within the voltage utilization range stamped on the unit nameplate. Voltage imbalance must not exceed 2 percent.

Min voltage – Average / Average
< 2%

And

Max Voltage – Average / Average
< 2%

- Check the unit power phasing to be sure that it has been installed in an "ABC" sequence.

WARNING Live Electrical Components!

During installation, testing, servicing and troubleshooting of this product, it may be necessary to work with live electrical components. Have a qualified licensed electrician or other individual who has been properly trained in handling live electrical components perform these tasks. Failure to follow all electrical safety precautions when exposed to live electrical components could result in death or serious injury.

- Fill the evaporator chilled water circuit. Vent the system while it is being filled. Open the vents on the top of the evaporator during filling and close when filling is completed.
- Vent the pump (option): It is recommended to vent the pump to make sure the seal is wet before pump start.
- Pump motors (option) are totally enclosed. In high humidity environments, condensation can occur in the motor, so it is recommended to remove plastic drain plug located at the bottom of the motor frame.

CAUTION! When using freeze inhibitor, never fill the system with pure glycol.

Always fill the system with diluted solution. Maximum concentration of Glycol is 40%. Higher glycol concentration will damage pump seal.

CAUTION! The pump must not run dry. Dry-running will damage the mechanical seal.

CAUTION Proper Water Treatment!

The use of untreated or improperly treated water in the CGAM may result in scaling, erosion, corrosion, algae or slime. It is recommended that the services of a qualified water treatment specialist be engaged to determine what water treatment, if any, is required. Trane assumes no

responsibility for equipment failures which result from untreated or improperly treated water, or saline or brackish water.

- Close the fused-disconnect switch(es) that supplies power to the chilled water pump starter.
- Start the chilled water pump to begin circulation of the water. Inspect all piping for leakage and make any necessary repairs.
- With water circulating through the system, adjust water flow and check water pressure drop through the evaporator.
- Prove all Interlock and Interconnecting Wiring Interlock and External.
- Check and set, as required, all CH530 Menu Items.
- Stop the chilled water pump.

Water System Flow Rates

Establish a balanced chilled water flow through the evaporator. The flow rates must fall between the minimum and maximum values. Chilled water flow rates below the minimum values will result in laminar flow, which reduces heat transfer and causes either loss of EXV control or repeated nuisance, low temperature cutouts.

Water System Pressure Drop

Measure water pressure drop through the evaporator at the field-installed pressure taps on the system water piping. Use the same gauge for each measurement. Measure flow at the field-installed supply and return. This will include valves, strainers, and fittings in the pressure drop readings. Pressure drop readings should be approximately those shown in the Pressure Drop Charts in the Installation-Mechanical section.

Caution! Strainer should be cleaned after water flow has been established for the first time, as it is likely that it collects all the particles left after field installation.

Unit Start-Up Procedures

Power Up

The Power up chart shows the respective DynaView screens during a power up of the main processor. This process takes from 30 to 45 seconds depending on the number of installed Options. On all power ups, the software model will always transition through the 'Stopped' Software state independent of the last mode. If the last mode before power down was 'Auto', the transition from 'Stopped' to 'Starting' occurs, but it is not apparent to the user.

Power Up to Starting

The Power up to starting diagram shows the timing from a power up event to energizing the compressor. The shortest allowable time would be under the following conditions:

1. No motor restart inhibit
2. Evaporator Water flowing
3. Power up Start Delay setpoint set to 0 minutes
4. Adjustable Stop to Start Timer set to 5 seconds
5. Need to cool

The above conditions would allow for a minimum power up to starting compressor time of 95 seconds.

Figure 32 - Power Up

CGAM Sequence of Operation:
Power Up

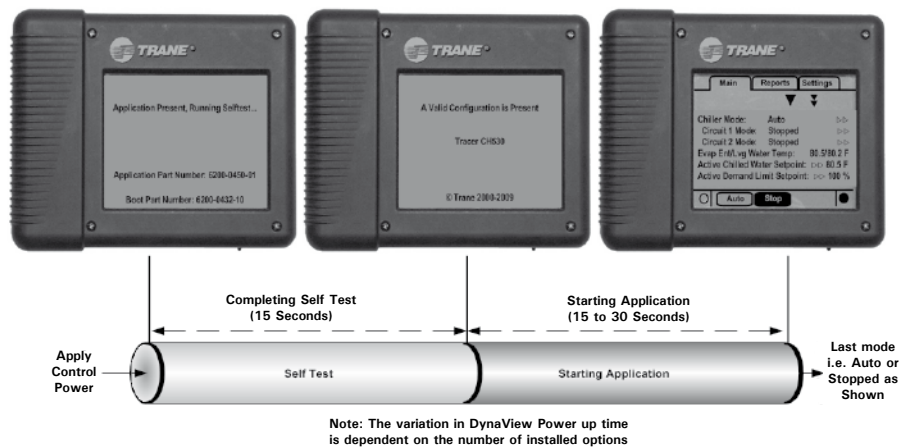

Unit Start-Up Procedures

Figure 33 - Power Up to Starting
CGAM Sequence of Operation
Power Up to Starting Compressor

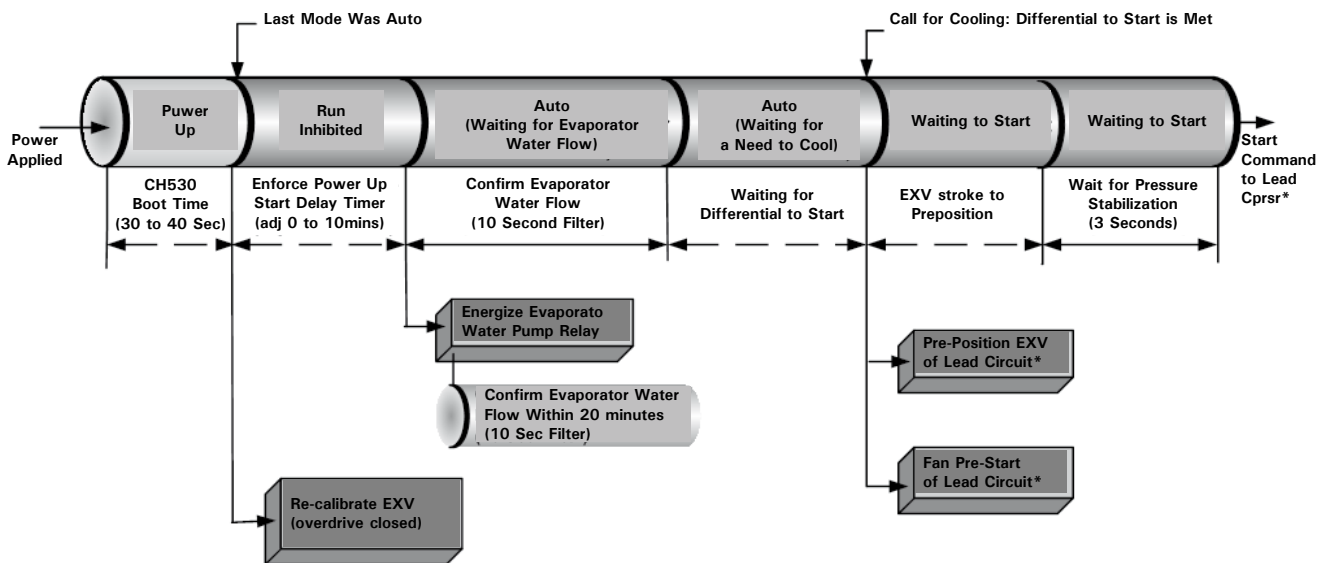

- * Lead Circuit/Compressor is determined by:
- Circuit Staging Option: Balanced Wear, Circuit 1 Lead, Circuit 2 Lead
 - Compressor Staging Option: Balanced Wear, Fixed Sequence (Follows per circuit configuration)
 - also influenced by lockouts, restart inhibit and diagnostics present

Stopped to Starting

The stopped to starting diagram shows the timing from a stopped mode to energizing the compressor. The shortest allowable time would be under the following conditions:

1. No motor restart inhibit
 2. Evaporator Water flowing
 3. Power up Start Delay Timer has expired
 4. Adjustable Stop to Start Timer has expired
 5. Need to cool
- The above conditions would allow the compressor to start in 60 seconds.

CAUTION Refrigerant!

If both suction and discharge pressures are low but sub-cooling is normal, a problem other than refrigerant shortage exists. Do not add refrigerant, as this may result in overcharging the circuit. Use only refrigerants specified on the unit nameplate (R410A) and Trane OIL0057E or OIL0058E. Failure to do so may cause compressor damage and improper unit operation.

CAUTION Equipment Damage!

Ensure that the oil sump heaters have been operating for a minimum of 24 hours before starting. Failure to do so may result in equipment damage.

Unit Start-Up Procedures

Start-up

CAUTION Equipment Damage!

Ensure that the oil sump heaters have been operating for a minimum of 24 hours before starting. Failure to do so may result in equipment damage. If the pre-start checkout, has been completed, the unit is ready to start.

1. Press the STOP key on the CH530.
2. As necessary, adjust the setpoint values in the CH530 menus using TechView.
3. Close the fused-disconnect switch for the chilled water pump. Energize the pump(s) to start water circulation.
4. Press the AUTO key. If the chiller control calls for cooling and all safety interlocks are closed, the unit will start. The compressor(s) will load and unload in response to the leaving chilled water temperature.
5. Verify that the chilled water pump runs for at least one minute after the chiller is commanded to stop (for normal chilled water systems).

Note: Once the system has been operating for approximately 30 minutes and has become stabilized, complete the remaining start-up procedures, as follows:

6. Check the evaporator refrigerant pressure and the condenser refrigerant pressure under Refrigerant Report on the CH530 TechView. The pressures are referenced to sea level.
7. Check the EXV sight glasses after sufficient time has elapsed to stabilize the chiller. The refrigerant flow past the sight glasses should be clear. Bubbles in the refrigerant indicate either low refrigerant charge or excessive pressure drop in the liquid line or a stuck open expansion valve. A restriction in the line can sometimes be identified by a noticeable temperature differential between the two sides of the restriction. Frost will often form on the line at this point. Proper refrigerant charges are shown in the General Data tables.

Note: Important!

A clear sight glass alone does not mean that the system is properly charged. Also check system subcooling, liquid level control and unit operating pressures.

8. Measure the system subcooling.
9. A shortage of refrigerant is indicated if operating pressures are low and subcooling is also low. If the operating pressures, sight glass, superheat and subcooling readings indicate a refrigerant shortage, gas-charge refrigerant into each circuit, as required. With the unit running, add refrigerant vapor by connecting the charging line to the suction service valve and charging through the backseat port until operating conditions become normal.

Print out a Chiller Service Report from TechView to file a start-up claim and to keep for reference with the chiller.

Figure 34 - Chiller State Chart

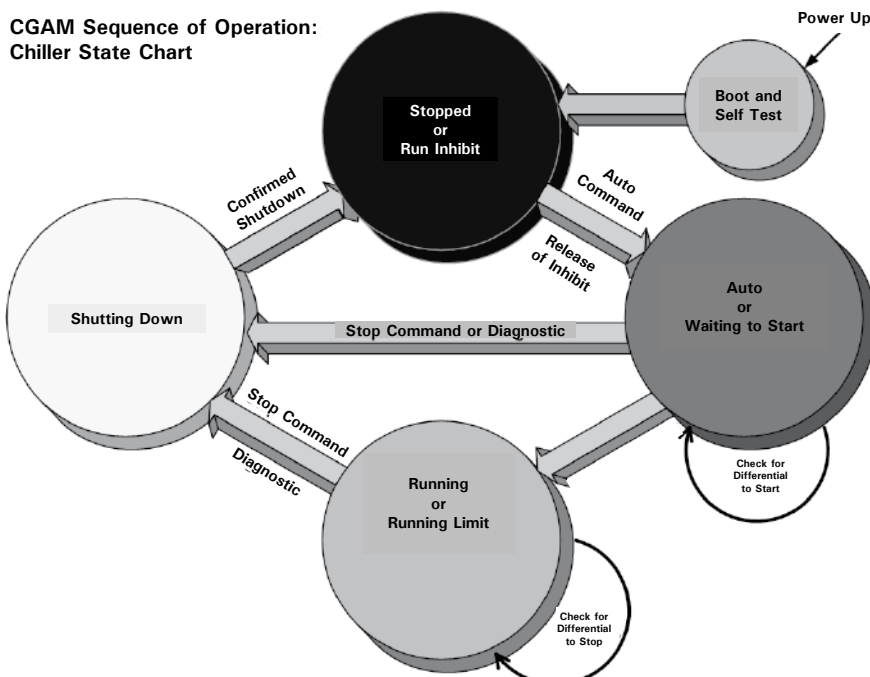

Unit Start-Up Procedures

Seasonal start-up

- Check water flows and interlocks.
- Check Ethylene glycol % in the chilled water circuit if glycol presence is required
- Check operational setpoints and performance.
- Check operation of all safety devices.
- Inspect contacts and tighten terminals.
- Megger the motor compressor windings.
- Record operating pressures, temperatures, amperages and voltage.
- Carry out leak test.
- Check configuration of unit control module.
- Change the oil as required based upon results of the oil analysis made during seasonal shutdown

CAUTION Equipment Damage!

Ensure that the oil sump heaters have been operating for a minimum of 24 hours before starting. Failure to do so may result in equipment damage.

Limit Conditions

CH530 will automatically limit certain operating parameters during startup and run modes to maintain optimum chiller performance and prevent nuisance diagnostic trips. These limit conditions are noted below.

Get the 8 condition measurements at the same time, on each circuit.

- HP
- LP
- Suction temperature
- Discharge temperature
- Liquid temperature
- Water entering temperature
- Water leaving temperature
- Outdoor ambient temperature

Then calculate the sub-cooling and superheat. No diagnosis can be accurate with one of these records missing.

- Check operation of machines/ compare conditions of operation against original commissioning data.
- Fill out the visit log sheet and review with the operator

Table 27 - Limit conditions

Running - Limited	The chiller, circuit, and compressor are currently running, but the operation of the chiller/compressor is being actively limited by the controls. Further information is provided by the sub-mode.
Capacity Limited by High Cond Press	The circuit is experiencing condenser pressures at or near the condenser limit setting. The compressor will be unloaded to prevent exceeding the limits.
Capacity Limited by Low Evap Rfght Temp	The circuit is experiencing saturated evaporator temperatures at or near the Low Refrigerant Temperature Cutout setting. The compressors will be unloaded to prevent tripping.

Unit Shut-Down Procedures

Normal Shutdown to Stopped

The Normal Shutdown diagram shows the Transition from Running through a Normal (friendly) Shutdown. The Dashed lines on the top attempt to show the final mode if you enter the stop via various inputs.

Note: Do not open the starter disconnect switch. This must remain closed to provide control power from the control power transformer to the oil heaters.

Ensure that all safeties are taken to prevent frost damages during negative ambient temperatures.

- Fill out the visit log sheet and review with the operator.
- Do not put the general disconnect switch to off, except if the unit is drained. Trane does not recommend draining the unit, due to the fact that it increases tube corrosion.

Seasonal Unit Shutdown

1. Carry out leak test
2. Carry out oil analysis
3. Record operating pressures
4. Check operation of machines and compare conditions of operation against original commissioning data.
5. Perform the normal unit stop sequence using the <Stop> key.

Figure 35 - Normal shutdown

CGAM Sequence of Operation Normal Shutdown to Stopped or Run Inhibit

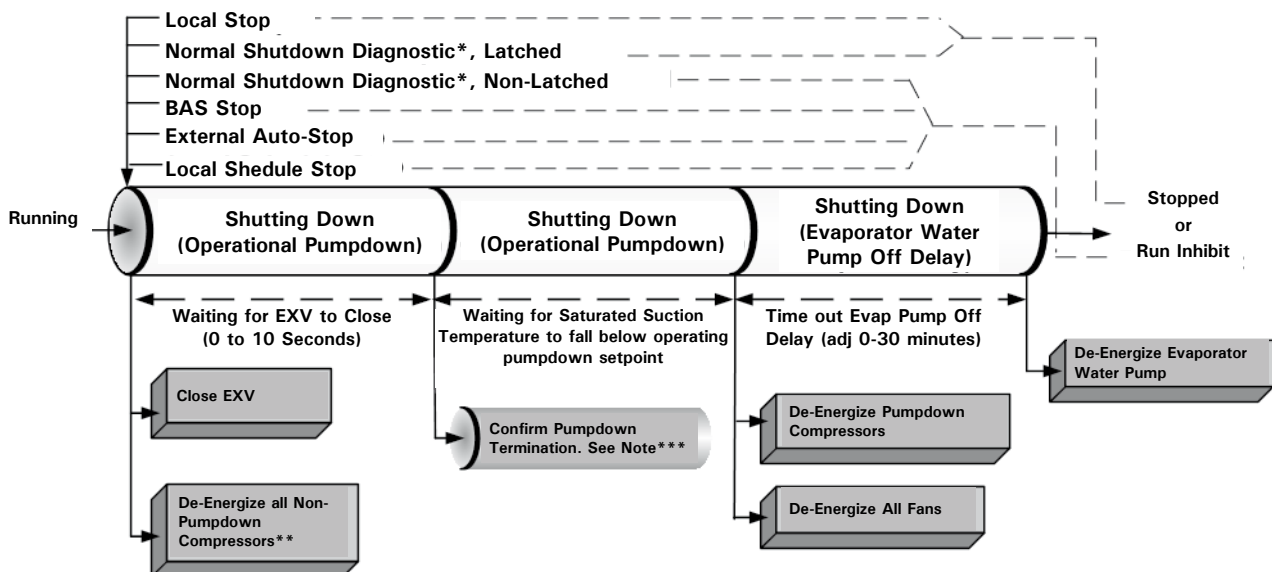

* Normal Shutdown Diagnostic:
- Chiller Level Diagnostic
- Circuit Level Diagnostic on only running circuit
- Compressor Level Diagnostic on only running compressor

** Pumpdown Compressor is:
- One compressor on each circuit running during Operational Pumpdown

*** If normal pumpdown termination does not occur within the Pumpdown Timeout

Maintenance

General

Perform all maintenance procedures and inspection at the recommended intervals. This will prolong the life of the chiller and minimize the possibility of malfunctions.

Use an "Operator's Log" to record the unit's operating history. The log serves as a valuable diagnostic tool for service personnel. By observing trends in operating conditions, an operator can anticipate and prevent problem situations before they occur. If the unit is not operating properly during maintenance inspections, consult the "Diagnostic and Troubleshooting" section of this manual.

Proper servicing of the service valves is required. Use a backup wrench as shown in Figure 36 when loosening or tightening the service valve cap.

Figure 36 - Servicing of service valves

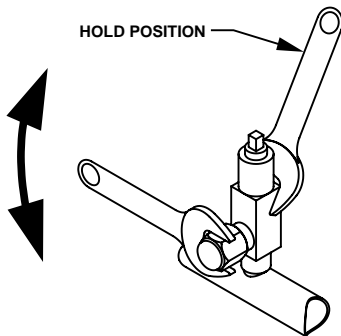

Weekly Maintenance

After the chiller has been operating for approximately 30 minutes and the system has stabilized, check the operating pressures and temperatures and complete the following checks:

Check the evaporator and condenser refrigerant pressures in the Refrigerant Report menu of the CH530 display.

Pressures are referenced at sea level.

Check the electronic expansion valve sight glasses. (Note: The electronic expansion valve is commanded closed at unit shutdown and if the unit is off, there will be no refrigerant flow through the sight glasses. Only when a circuit is running will refrigerant flow be present.) The refrigerant flow through the sight glasses should be clear. Bubbles in the refrigerant indicate either low refrigerant charge or excessive pressure drop in the liquid line. A restriction in the line can sometimes be identified by a noticeable temperature differential between the two sides of the restriction. Frost may often form on the liquid line at this point. Correct refrigerant charges are shown in Table 1-3.

NOTICE: A clear sight glass alone does not mean that the system is properly charged. Also check the system superheat, subcooling and unit operating pressures.

NOTICE: Use only manifold gauge sets designed for use with R410A refrigerant.

Use only recovery units and cylinders designed for the higher pressure of R410A refrigerant and POE oil.

NOTICE: R410A must be charged in a liquid state.

Check the system superheat, subcooling, evaporator temperature drop (Delta-T), evaporator water flow, evaporator approach temperature, compressor discharge superheat, and compressor RLA.

Normal operating conditions at ISO conditions are:

Evaporator pressure: 8 bars

Evaporator Approach: 3-5°C

Evaporator Superheat: 6-7°C

Electronic Expansion Valve: 30-50 percent open

Evaporator Temperature Temperature Drop (Delta-T): 5°C

Condensing Pressure: 28-32 bars

Condensing Approach Temperature: 14-18°C

System Subcooling: 8-12°C

If operating pressures and sight glass conditions seem to indicate a refrigerant shortage, measure the system superheat and subcooling. Refer to "System Superheat" and "System Subcooling."

If operating conditions indicate a refrigerant overcharge, remove refrigerant at the liquid line service valve. Allow refrigerant to escape slowly to minimize oil loss. Use a refrigerant recovery cylinder and do not discharge refrigerant into the atmosphere.

WARNING!

Do not allow refrigerant to directly contact skin as injury from frostbite may result.

Inspect the entire system for unusual conditions and inspect the condenser coils for dirt and debris. If the coils are dirty, refer to "Coil Cleaning" in this manual.

Maintenance

Monthly Maintenance

Complete all weekly maintenance procedures.

Measure and record the evaporator superheat. Refer to "Evaporator Superheat."

Measure and record the system subcooling. Refer to "System Subcooling."

Check coil cleanliness and clean them if required.

Manually rotate the condenser fans to ensure that there is proper clearance on the fan shroud openings.

Check water pump (option):
Manually rotate the pump. Remove plastic plug located at the bottom of the motor frame to drain any condensation which can occur in the motor.

Check and clean air filter of the control panel (option)

In case of Twin-pump, make sure there is no pump motor fault.

Note: pump operation will be alternated at each new request of water flow or when a pump fault is detected.

WARNING! Position all electrical disconnects in the "OPEN" position and lock them to prevent injury or death due to electrical shock or moving parts.

Annual Maintenance

Complete all weekly and monthly maintenance checks.

Check the oil level and refrigerant charge. Routine changing of oil is not required.

Have a qualified laboratory perform a compressor oil analysis to determine system moisture content and acid level.

This analysis is a valuable diagnostic tool. Trane laboratory is specifically dedicated to oil analysis for Trane equipment.

Contact a qualified service provider to leak test the chiller, check operating and safety controls, and to inspect electrical components for proper operation. Leak testing may be accomplished using soap solution or with electronic or ultrasonic leak detectors. Inspect all piping components for leaks and damage.

Clean all water strainers.

NOTICE: If the CGAM chiller evaporator is drained of water, the freeze protection heater must be de-energized. Failure to de-energize the heater might cause it to burn out.

Clean and repaint any components that show corrosion. Clean the condenser coils. Refer to "Condenser coil Cleaning" in this manual.

WARNING!

Position all electrical disconnects in the "OPEN" position and lock them to prevent injury or death due to electrical shock or moving parts.

Clean the condenser fans. Check the fan assemblies for proper clearance in the fan shroud openings and for motor shaft misalignment or abnormal end-play, vibration and noise.

Compressor Service Information

Compressor Electrical Connections

It is very important that CSHD compressors used in Trane Model CGAM chillers are wired correctly for proper rotation. These compressors will not tolerate reverse rotation. Verify correct rotation/phasing using a rotation meter.

Proper phasing is clockwise, A-B-C. If wired incorrectly a CSHD compressor will make excessive noise, will not pump and will draw about half the normal current. It will also become very hot if allowed to run for an extended period.

NOTICE: Do not “bump” the compressor to check rotation as incorrect rotation could cause compressor motor failure in as little as 4 to 5 seconds!

Correct rotation of CSHN compressors is also clockwise, with A-B-C phasing. Improper rotation of the CSHN compressors is indicated by a compressor module trip, noisy operation, no pressure difference on manifold gauges and low amp draw.

Oil Level

To check compressor oil level, refer to the label near the compressor sight glass. The compressor(s) must be off. Wait three minutes. With tandem or triple compressors the oil level will equalize after shutdown. Compressor oil level should be no lower than the bottom of the sight glass and no more than a full sight glass. When operating, each compressor in a tandem or trio set may have a different oil level. The oil level may not be in the sight glass, but it must be visible through the sight glass.

Oil Fill, Removal and Capacity

The Model CSHN compressors have an oil charging valve with a dip tube that goes to the bottom of the compressor. This can be used to add or remove oil from the compressor.

Model CSHD compressors have a Schrader valve in the middle of the compressor which is used to add oil. To remove oil from these compressors, the system refrigerant charge must be removed and then the oil can be removed using a suction style hand pump and tube in the oil equalizer tube fitting. Oil can also be added to these compressors through the oil equalizer tube fitting. Care must be taken to prevent moisture from entering the systems when adding oil. Note that the POE oil used in this product is very hygroscopic and easily absorbs and retains moisture. Moisture is very difficult to remove from oil using vacuum. Also note that once the seal on a container of POE oil is opened, the oil must be used.

Compressor Capacity

CSHD 120, 161 — 3.3 l

CSHN 184, 250, 315 — 6.7 l

CSHN 374 — 7.2 l

Use only Trane OIL0057 (3.8 l) or OIL00058E (18.9 l). These are the same oil but different container size. Do not use any other POE oil.

NOTE: Never reuse oil.

Oil Testing

We recommend performing a complete oil analysis at least once a year with the Trane laboratory specifically dedicated to oil analysis for Trane equipment. It provides an in-depth view of both compressor and refrigerant circuit conditions including presence of water, wear particles, viscosity, acidity or dielectric data. If unacceptable wear conditions develop, a change in the characteristics of the oil will be evident. Minor problems can be detected and repaired before they become major problems.

Single circuit units: order reference ANL0008E

Dual circuit units: order reference ANL0006E

Compressor Service Information

Oil Equalizer Line

CSHN Compressors

The oil equalizer line is equipped with a Rotolock fitting for easy removal. Torque value for tightening these fitting is 120 N.m Drain the oil to a level below the oil equalizer tube fitting before removing the oil equalizer line. This must be done on both compressors. Use the oil drain valve on the compressor. If the oil is drained below the level of the oil level sight glass, it will be below the oil equalizer line level. Pressurize the low side of the compressor using nitrogen to help drain the oil. No more than 70 kPa of pressure will be needed.

CSHD Compressors

CSHD compressors do not have an oil drain valve. Therefore, before removing the oil equalizer line, the system refrigerant charge must be recovered before draining the oil. Use a catch pan to catch the oil when the compressor oil equalizer line is loosened to ensure that oil does not spill out of the compressor when the equalizer line is removed. The torque value for the Rotolock fitting on CSHD compressors is 90 N.m

Tandem and Triple Compressor Suction Restrictors

Since most tandem and triple compressor sets use unequal size compressors, these combinations require the use of a restrictor in the suction line of one or more compressors in order to provide correct oil level balance between compressors when they are operating.

Compressor Replacement

If the CGAM chiller suffers a failed compressor, use these steps for replacement:

Each compressor has lifting eyes. Both lifting eyes must be used to lift the failed compressor. **DO NOT LIFT A COMPRESSOR USING A SINGLE LIFTING EYE.** Use proper lifting techniques, a spreader bar and rigging as for lifting both compressors simultaneously.

Compressor weights by compressor model are:

- CSHD 120 – 69 kg.
- CSHD 161 – 69 kg.
- CSHN 184 – 106 kg.
- CSHN 250 – 108 kg.
- CSHN 315 – 153 kg.
- CSHN 374 – 164 kg.

After a mechanical failure of a compressor, it is necessary to change the oil in the remaining compressor and also replace the liquid line filter drier. After an electrical failure of a compressor, it will also be necessary to change the oil in the remaining compressor, replace the liquid line filter drier and add a suction filter drier with clean-up cores.

Note: Do not alter the refrigerant piping in any way as this can affect compressor lubrication.

Note: Do not add a suction filter drier within 250mm of the elbow for CSHD compressors, or within 400mm of the elbow for CSHN compressors.

Refrigerant System Open Time

Model CGAM chillers use POE oil and therefore refrigerant system open time must be kept to a minimum. The following procedure is recommended:

Leave a new compressor sealed until it is ready to be installed in the unit. Maximum system open time is dependent upon ambient conditions, but do not exceed one hour open time.

Plug the open refrigerant line to minimize moisture absorption. Always change the liquid line filter drier.

Evacuate the system to 500 microns or below.

Do not leave POE oil containers open to the atmosphere. Always keep them sealed.

Mechanical Compressor Failure

Replace the failed compressor(s) and change the oil in the remaining compressor(s) along with the refrigerant system liquid line filter drier.

Compressor Service Information

Electrical Compressor Failure

Replace the failed compressor and change the oil in the other compressor(s). Also add a suction filter with cleanup cores and change the liquid line filter drier. Change filters and oil until the oil no longer test acidic. See "Oil Testing."

Compressor Motor Megging

Motor megging determines the electrical integrity of the compressor motor winding insulation. Use a 500 volt megger. A less than 1 meg-ohm reading is acceptable and 1000 ohms per nameplate volts is required to safely start the compressor.

Compressor Current Imbalance

Normal current imbalance could be 4 to 15 percent with balanced voltage due to motor design. Each phase should register .3 to 1.0 ohms and each phase should be within 7 percent of the other two phases. Phase to ground resistance must be infinity.

NOTICE: Maximum allowable voltage imbalance is 2 percent.

Refrigerant Piping

The compressor suction and discharge connections and piping are copper clad steel for easy brazing. In most instances, piping may be reused. If piping is not reusable, order the correct service parts. Cut all tubing with a tubing cutter to prevent copper filings from entering the system. Cut the tubing in a straight length of pipe after the compressor connection has been unsweated. The line can then be reinstalled using a slip coupling and brazing.

NOTICE: The compressor suction line configuration must not be changed in any way. Changing compressor suction line configuration will compromise proper oil return to the compressor(s).

Compressor Electrical Terminal Box

Be sure to protect the terminal box when unbrazing or brazing compressor refrigerant piping connections

Compressor Crankcase Heaters

Compressor crankcase heaters must be energized at least eight hours before starting the CGAM chiller. This is required to boil refrigerant out of the oil before startup. Ambient temperature is not a factor and the crankcase heaters must always be energized prior to startup.

Condenser Maintenance

Condenser Coil Cleaning

Clean the condenser coils at least once a year or more frequently if the unit is in a "dirty" environment. A clean condenser coil will help to maintain chiller operating efficiency. Follow the detergent manufacturer's instructions to avoid damaging the condenser coils.

Black epoxy coil protection (option)

It is recommended to clean the coils at unit start-up and regularly to obtain optimum protection and life span of the condenser coils.

To clean the condenser coils use a soft brush and a sprayer such as a garden pump type or a high-pressure type. A high quality detergent such as Trane Coil Cleaner is recommended.

Note: If detergent mixture is strongly alkaline (pH value greater than 8.5), an inhibitor must be added.

Compressor Service Information

Evaporator Maintenance

The Trane Model CGAM liquid chiller uses a brazed plate heat exchanger (BPHE) evaporator with factory-installed electronic flow switch that is positioned in the evaporator water pipe. The evaporator inlet also includes an optional water strainer that must be kept in place to keep debris out of the evaporator.

Note: *Strainer maintenance is critical to proper operation and reliability. Any particles larger than 1.6 mm entering the BPHE evaporator may cause the evaporator to fail, requiring replacement.*

Acceptable BPHE evaporator water flow rate is 1.4 to 4.2 l/min per nominal unit kW capacity. To maintain 12-7°C in/out chilled water temperatures, the nominal water flow rate is 2.8 l/min per cooling kW.

Minimum water flow rate must be maintained to avoid laminar flow, potential evaporator freezing, scaling and poor temperature control.

Maximum water flow is 6 m/s. Flow rates greater than this will cause excessive erosion.

The BPHE evaporator is difficult to clean should it become plugged with debris. Indications of a plugged BPHE evaporator include "wet" suction due to lack of heat exchange, loss of superheat control, discharge superheat less than 35°C, compressor oil dilution and/or starvation and premature compressor failure.

Evaporator replacement

If the CGAM evaporator requires replacement, it is very important that the new evaporator be replaced correctly and with the correct refrigerant and water piping connections. The refrigerant inlet/liquid connection is at the bottom of the evaporator and the refrigerant outlet/suction connection is at the top of the evaporator and both are on the same side. Pay particular attention to evaporators with dual circuits. Avoid cross-circuiting when installing the new evaporator.

Water pump maintenance

CAUTION! The lifting eyebolts of the motor are suitable for the weight of the motor. It is not allowed to carry the complete pump on the lifting eyebolts of the motor

The motor bearing does not require any maintenance. Increasing bearing noise and undue vibration indicate a worn bearing. The bearing or the complete motor then needs replacing.

The mechanical seal does not require any special maintenance. Visual leakage check are however required. Distinctly visible leakage will require an exchange of the seal.

Follow instruction included in the seal kit.

Notes

Notes



Trane optimizes the performance of homes and buildings around the world. A business of Ingersoll Rand, the leader in creating and sustaining safe, comfortable and energy efficient environments, Trane offers a broad portfolio of advanced controls and HVAC systems, comprehensive building services, and parts. For more information, visit www.Trane.com.

Trane has a policy of continuous product and product data improvement and reserves the right to change design and specifications without notice.

© 2011 Trane All rights reserved
CG-SVX19C-E4 September 01, 2011 Supersedes: CG-SVX19B-E4 April 01, 2010

